

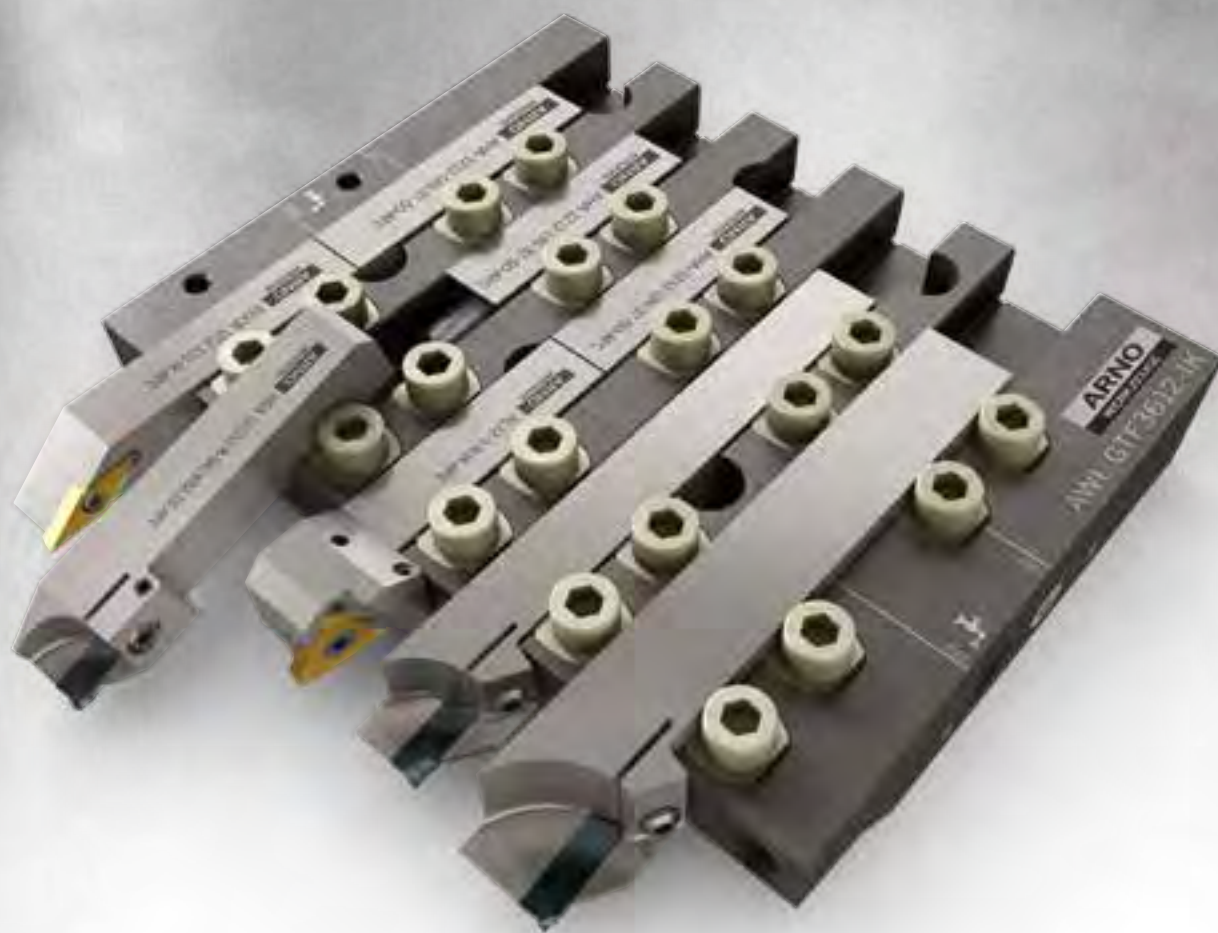

Katalogergänzung Langdrehen
Product expansion auto lathes
Ampliamento gamma fantina mobile



Sehr geehrter Kunde,

mit dieser Broschüre möchten wir Ihnen unsere aktuellen Produktergänzungen und Produktneuheiten in dem Bereich Langdrehen vorstellen, die wir durch die enge Zusammenarbeit mit Ihnen ständig vorantreiben. Details, Informationen und Anwendungshinweise zu den einzelnen Produktergänzungen finden Sie in den jeweiligen Kapiteln unseres Hauptkatalogs Langdrehen.

Profitieren Sie nebenbei von den ARNO® Serviceleistungen wie Sonderlösungen, Lieferungen über Nacht und ein kompetentes Außendienst- und Anwendungstechniker-Team.

Viel Vergnügen beim Lesen! Sollten Sie Fragen oder Anregungen zu unseren Produkten haben, sprechen Sie uns einfach an.

Ihr ARNO®-Team

Dear customer,

With this brochure we would like to present our new product expansions for sliding head auto lathes applications. Detailed information of the general tool range you will find in our main catalogue: Tools and inserts for sliding head auto lathes.

In addition to our excellent products we offer overnight delivery service, competent special solutions where our standards may not suffice and a qualified team of external technical sales engineers.

Enjoy your reading and should you have any questions, please do not hesitate to contact us.

Your ARNO® team

Gentile Cliente,

Con questo opuscolo vogliamo presentare le nostre novità e gli ultimi ampliamenti gamma prodotto per le lavorazioni di macchine a fantina mobile. Vogliamo costantemente guardare agli sviluppi futuri attraverso una stretta collaborazione con voi.

Ulteriori dettagli, informazioni e istruzioni sui singoli prodotti si trovano nei rispettivi capitoli del nostro catalogo generale di macchine a fantina mobile.

Il riconosciuto servizio ARNO® offre consegne entro le 24h e un supporto tecnico sul campo competente.

Buona lettura! Se avete domande o suggerimenti sui nostri prodotti, non esitate a contattarci.

Il nostro ARNO®-Team

**Produktergänzung
Langdrehen**

*Product expansion
Sliding head auto lathes*

Ampliamento gamma
Macchine a fantina mobile

<p>SA-Steichsystem</p> <ul style="list-style-type: none"> • Monoblockhalter • Schneideinsätze • Empfohlene Schnittwerte 	<p><i>SA-Grooving system</i></p> <ul style="list-style-type: none"> • <i>Monoblock holders</i> • <i>Inserts</i> • <i>Recommended cutting data</i> 	<p>SA-Sistema di troncatura</p> <ul style="list-style-type: none"> • Utensili monoblocco 4 - 7 • Inserti 8 - 10 • Parametri di taglio suggeriti 11 - 13
<p>SE-Steichsystem</p> <ul style="list-style-type: none"> • Schneideinsätze • Empfohlene Schnittwerte 	<p><i>SE-Grooving system</i></p> <ul style="list-style-type: none"> • <i>Inserts</i> • <i>Recommended cutting data</i> 	<p>SE-Sistema di troncatura</p> <ul style="list-style-type: none"> • Inserti 14 • Parametri di taglio suggeriti 15 - 17
<p>AMS ARNO-Mini-System</p> <ul style="list-style-type: none"> • Klemmhalter mit Schraubenklemmung • Klemmhalter - Spezielle Ausführung • Schneideinsätze • Empfohlene Schnittwerte 	<p><i>AMS ARNO-Mini-System</i></p> <ul style="list-style-type: none"> • <i>Holders with screw clamping</i> • <i>Special holder</i> • <i>Inserts</i> • <i>Recommended cutting data</i> 	<p>AMS ARNO-Mini-System</p> <ul style="list-style-type: none"> • Steli con fissaggio a vite 18 - 26 • Adattatore speciali 27 - 31 • Inserti 32 - 36 • Parametri di taglio suggeriti 37 - 39
<p>AFC-System</p> <ul style="list-style-type: none"> • Systemvorstellung • Monoblockhalter ATS • Geometriebeschreibung und Sortenbeschreibung ATS • Schneideinsätze ATS • Empfohlene Schnittwerte • Anwendungshinweise • Klemmhalter mit Schraubenklemmung • Anschlag 	<p><i>AFC-System</i></p> <ul style="list-style-type: none"> • <i>Introduction</i> • <i>Monoblock holders ATS</i> • <i>Geometry description and Grade discription ATS</i> • <i>Inserts ATS</i> • <i>Recommended cutting data</i> • <i>Application reference</i> • <i>Tool holders with screw clamping</i> • <i>Fix stop</i> 	<p>AFC-Sistema</p> <ul style="list-style-type: none"> • Caratteristiche del sistema 40 - 47 • Utensili monoblocco ATS 48 • Descriptione delle Geometria e Descrizione della Qualità ATS 49 • Inserti ATS 50 - 52 • Parametri di taglio suggeriti 53 - 55 • Suggestimenti tecnici 56 • Utensili monoblocco 58 - 85 • Fermo 86 - 89
<p>AWL-Linearschlitten</p> <ul style="list-style-type: none"> • Systemvorstellung • Werkzeughalter – CITIZEN • Werkzeughalter – DMG • Werkzeughalter – HANWHA • Werkzeughalter – STAR • Anwendungshinweise 	<p><i>AFC-System</i></p> <ul style="list-style-type: none"> • <i>Introduction</i> • <i>Toolholder – CITIZEN</i> • <i>Toolholder – DMG</i> • <i>Toolholder – HANWHA</i> • <i>Toolholder – STAR</i> • <i>Application reference</i> 	<p>AFC-Sistema</p> <ul style="list-style-type: none"> • Caratteristiche del sistema 90 - 95 • Portautensili – CITIZEN 96 - 105 • Portautensili – DMG 106 • Portautensili – HANWHA 107 - 110 • Portautensili – STAR 111 - 129 • Suggestimenti tecnici 130 - 131
<p>Langdrehen</p> <ul style="list-style-type: none"> • Systemvorstellung • Klemmhalter Außenbearbeitung • Anfrage Innenkühlung Klemmhalter -AN-IK • Klemmhalter - INDEX/TRAUB • Klemmhalter Innenbearbeitung 	<p><i>Auto lathes</i></p> <ul style="list-style-type: none"> • <i>Introduction</i> • <i>Tool holders External machining</i> • <i>Enquiry through tool coolant access tool holder -AN-IK</i> • <i>Holder - INDEX/TRAUB</i> • <i>Tool holders Internal machining</i> 	<p>Fantina mobile</p> <ul style="list-style-type: none"> • Caratteristiche del sistema 132 • Utensili 133 - 140 • Lavorazione esterna • Modulo di richiesta per adduzione interna steli -AN-IK 141 • Steli con bloccaggio - INDEX/TRAUB 142 - 146 • Utensili 147 - 152 • Lavorazione interna
<p>Wendescheidplatten</p> <ul style="list-style-type: none"> • Wendeschneidplatten Hartmetall • Wendeschneidplatten Hochpositiv • Wendeschneidplatten CERMET 	<p><i>Inserts</i></p> <ul style="list-style-type: none"> • <i>Inserts Carbide</i> • <i>High positiv</i> • <i>Inserts CERMET</i> 	<p>Inserti</p> <ul style="list-style-type: none"> • Inserti Metallo duro 153 - 159 • Inserti Ultra positiv 160 - 166 • Inserti Metallo CERMET 168 - 176

HSA-UD-ACS1-S...

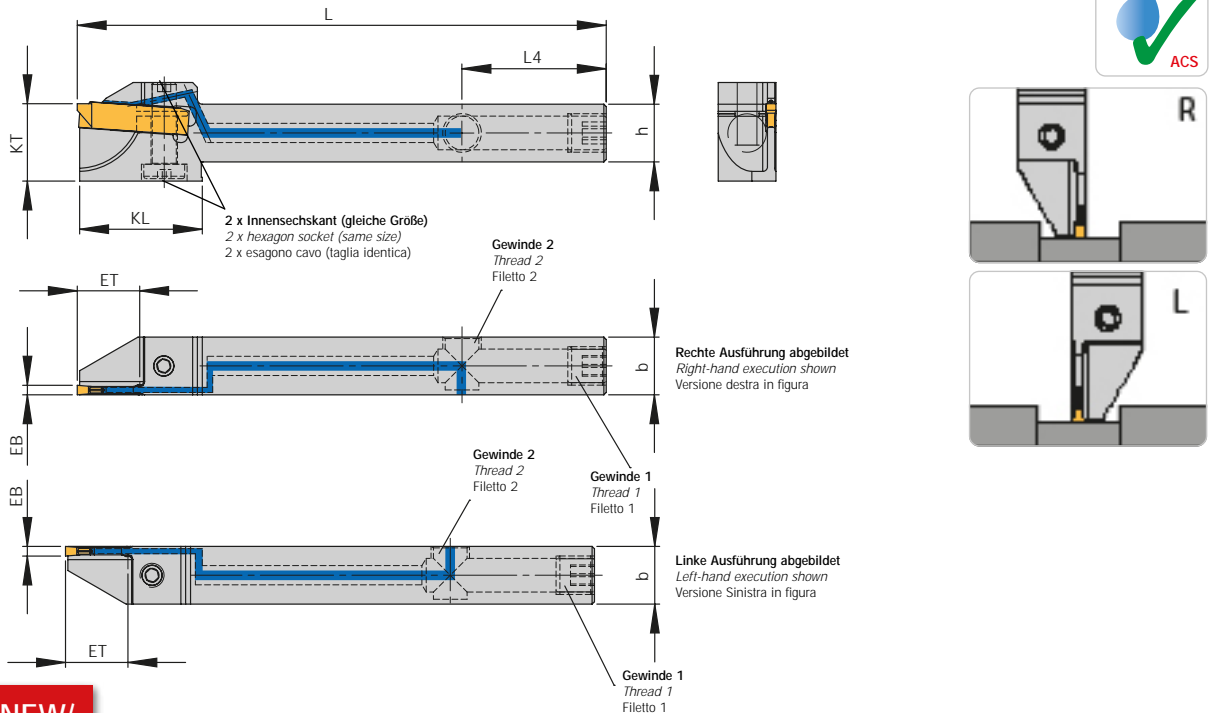

N NEU/NEW/
NUOVO

Trägerwerkzeuge / Holders / Utensili

Kühlmittelanschluss auf der Seite der Schneide / Coolant supply on the side of the cutting edge / Raccordo sul lato l'inserto

Artikel Article Articolo	EB	ET	D _{max}	D _R	h	b	L	L ₄	KL	KT	Gewinde 1 Thread 1 Filetto 1	Gewinde 2 Thread 2 Filetto 2	Schneideinsatz Insert Inserto
HSA 1212UD-L-SA2402-26-ACS1-S2 N	2,0	13	26	-	12	12	110	30	26	16	M8x1	M8x1	SA24-20...
HSA 1212UD-R-SA2402-26-ACS1-S1 N	2,0	13	26	-	12	12	110	30	26	16	M8x1	M8x1	SA24-20...

Ersatzteile / Spare Parts / Ricambi

Trägerwerkzeug Holder Utensile	Schraube Screw Vite	Schlüssel Key Chiave
HSA 1212UD...SA2402-26-ACS1-S...	AS 0084	KP 3111

Zubehör / Accessories / Accessori

Bezeichnung Designation Articolo	A	B
KA 001 Kühlmittelanschluss – gerade Coolant supply – straight Raccordo – dritto	M8x1	Ø 6 mm
KA 002	1/8"	Ø 6 mm
KA 004 Kühlmittelanschluss – winklig, fest Coolant supply – angled and fixed Raccordo – angolato	M8x1	Ø 6 mm
KA 005	1/8"	Ø 6 mm
KA 006 Schwenkverschraubung Swivelling screw-fitting Raccordo – orientabile	M8x1	Ø 6 mm
KA 007	1/8"	Ø 6 mm

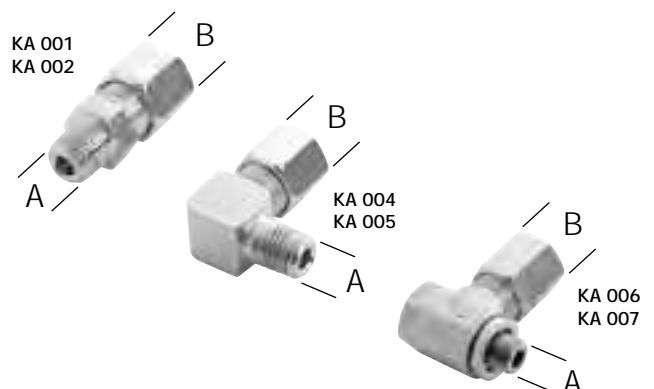

HSA-UD-ACS1-S2/S2G

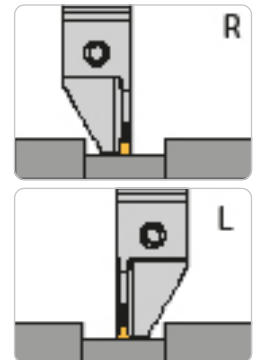
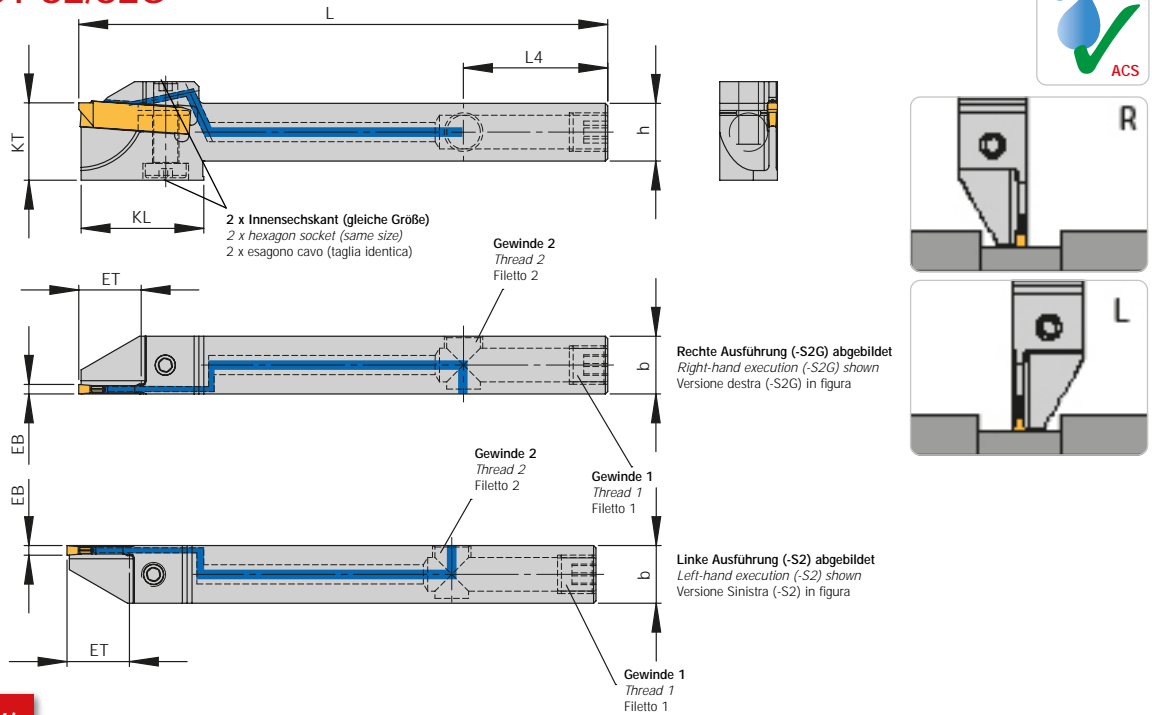

Trägerwerkzeuge / Holders / Utensili

Kühlmittelschluss auf der Seite der Schneide / Coolant supply on the side of the cutting edge / Raccordo sul lato l'inserto

Artikel Article Articolo	EB	ET	D _{max}	D _R	h	b	L	L ₄	KL	KT	Gewinde 1 Thread 1 Filetto 1	Gewinde 2 Thread 2 Filetto 2	Schneideinsatz Insert Inserto
HSA 1616UD-L-SA2402-26-ACS1-H2-S2 N	2,0	13	26	-	16	16	110	30	25	16	G1/8"	G1/8"	SA24-20...
HSA 1616UD-R-SA2402-26-ACS1-H2-S2 N	2,0	13	26	-	16	16	110	30	25	16	G1/8"	G1/8"	SA24-20...

Trägerwerkzeuge / Holders / Utensili

Kühlmittelschluss auf der gegenüberliegenden Seite der Schneide / Coolant supply on the opposite side of the cutting edge / Raccordo sul lato opposto l'inserto

Artikel Article Articolo	EB	ET	D _{max}	D _R	h	b	L	L ₄	KL	KT	Gewinde 1 Thread 1 Filetto 1	Gewinde 2 Thread 2 Filetto 2	Schneideinsatz Insert Inserto
HSA 1616UD-L-SA2402-26-ACS1-H2-S2G N	2,0	13	26	-	16	16	110	30	25	16	G1/8"	G1/8"	SA24-20...
HSA 1616UD-R-SA2402-26-ACS1-H2-S2G N	2,0	13	26	-	16	16	110	30	25	16	G1/8"	G1/8"	SA24-20...

Ersatzteile / Spare Parts / Ricambi

Trägerwerkzeug Holder Utensile	Schraube Screw Vite	Schlüssel Key Chiave
HSA 1616UD...SA2402-26-ACS1-S...	AS 0084	KP 3111

Zubehör / Accessories / Accessori

Bezeichnung Designation Articolo	A	B
KA 001 Kühlmittelschluss - gerade Coolant supply - straight Raccordo - dritto	M8x1	Ø 6 mm
KA 002	1/8"	Ø 6 mm
KA 004 Kühlmittelschluss - winklig, fest Coolant supply - angled and fixed Raccordo - angolato	M8x1	Ø 6 mm
KA 005	1/8"	Ø 6 mm
KA 006 Schwenkverschraubung Swivelling screw-fitting Raccordo - orientabile	M8x1	Ø 6 mm
KA 007	1/8"	Ø 6 mm

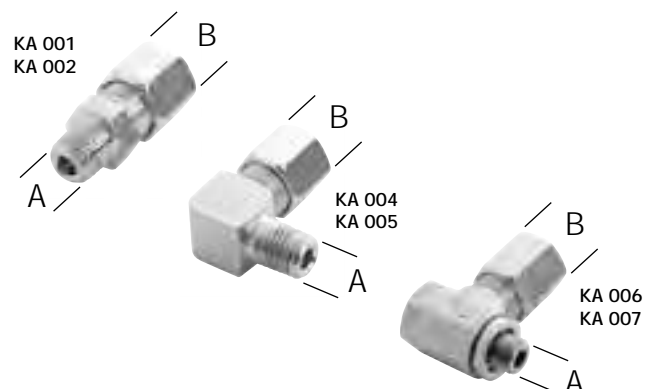

HSA-UD-ACS2-S1/S1G

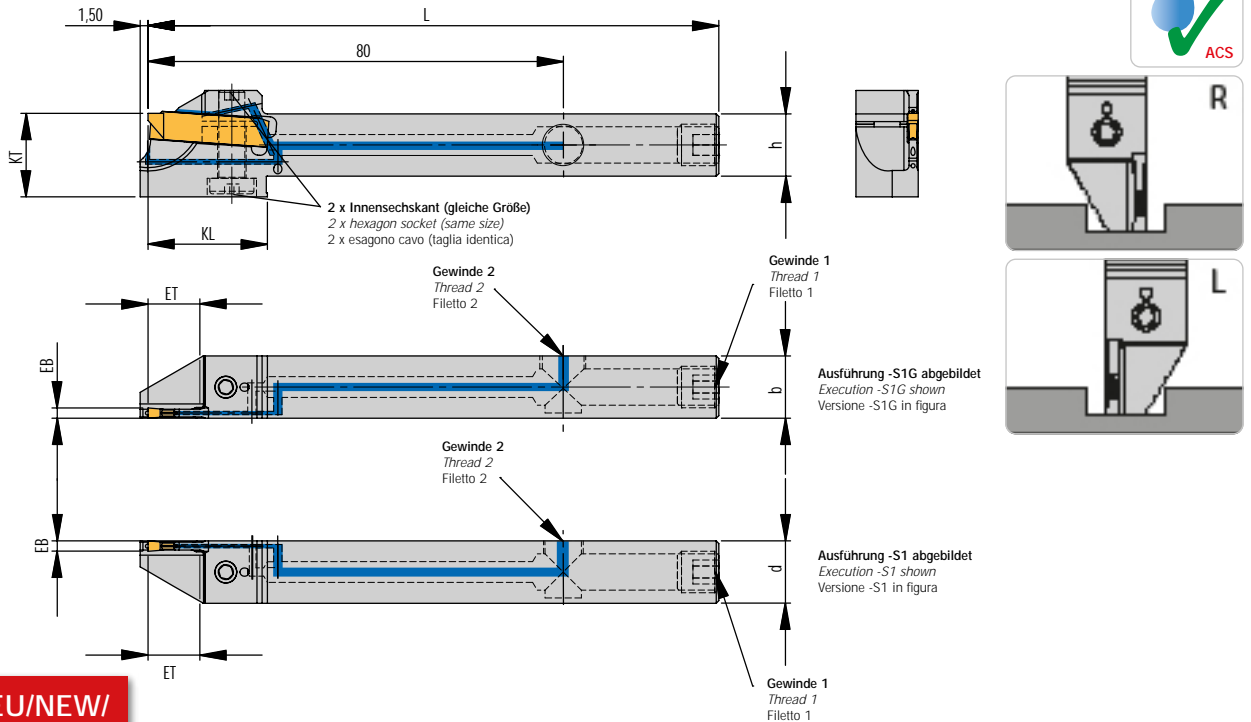

Trägerwerkzeuge / Holders / Utensili

Kühlmittelanschluss auf der Seite der Schneide / Coolant supply on the side of the cutting edge / Raccordo sul lato l'inserto

Artikel Article Articolo	EB	ET	D _{max}	D _R	h	b	L	L ₄	KL	KT	Gewinde 1 Thread 1 Filetto 1	Gewinde 2 Thread 2 Filetto 2	Schneideinsatz Insert Inserto
HSA 1212UD-R-SA2402-12-ACS2-S1 N	2,0	6	12	-	12	12	110	30	19	18	M8x1	M8x1	SA24-20...
HSA 1212UD-R-SA2402-16-ACS2-S1 N	2,0	8	16	-	12	12	110	30	21	20	M8x1	M8x1	SA24-20...

Trägerwerkzeuge / Holders / Utensili

Kühlmittelanschluss auf der gegenüberliegenden Seite der Schneide / Coolant supply on the opposite side of the cutting edge / Raccordo sul lato opposto l'inserto

Artikel Article Articolo	EB	ET	D _{max}	D _R	h	b	L	L ₄	KL	KT	Gewinde 1 Thread 1 Filetto 1	Gewinde 2 Thread 2 Filetto 2	Schneideinsatz Insert Inserto
HSA 1212UD-R-SA2402-12-ACS2-S1G N	2,0	6	12	-	12	12	110	30	19	18	M8x1	M8x1	SA24-20...
HSA 1212UD-R-SA2402-16-ACS2-S1G N	2,0	8	16	-	12	12	110	30	21	20	M8x1	M8x1	SA24-20...

Ersatzteile / Spare Parts / Ricambi

Trägerwerkzeug Holder Utensile	Schraube Screw Vite	Schlüssel Key Chiave
HSA 1212UD...SA2402-...-ACS2-S1...	AS 0084	KP 3111

Zubehör / Accessories / Accessori

Bezeichnung Designation Articolo	A	B
KA 001 Kühlmittelanschluss - gerade Coolant supply - straight Raccordo - dritto	M8x1	Ø 6 mm
KA 002	1/8"	Ø 6 mm
KA 004 Kühlmittelanschluss - winklig, fest Coolant supply - angled and fixed Raccordo - angolato	M8x1	Ø 6 mm
KA 005	1/8"	Ø 6 mm
KA 006 Schwenkverschraubung Swivelling screw-fitting Raccordo - orientabile	M8x1	Ø 6 mm
KA 007	1/8"	Ø 6 mm

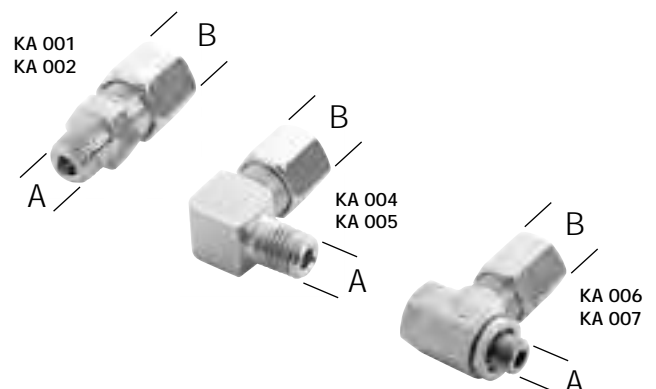

HSA-UD-ACS2-S2/S2G

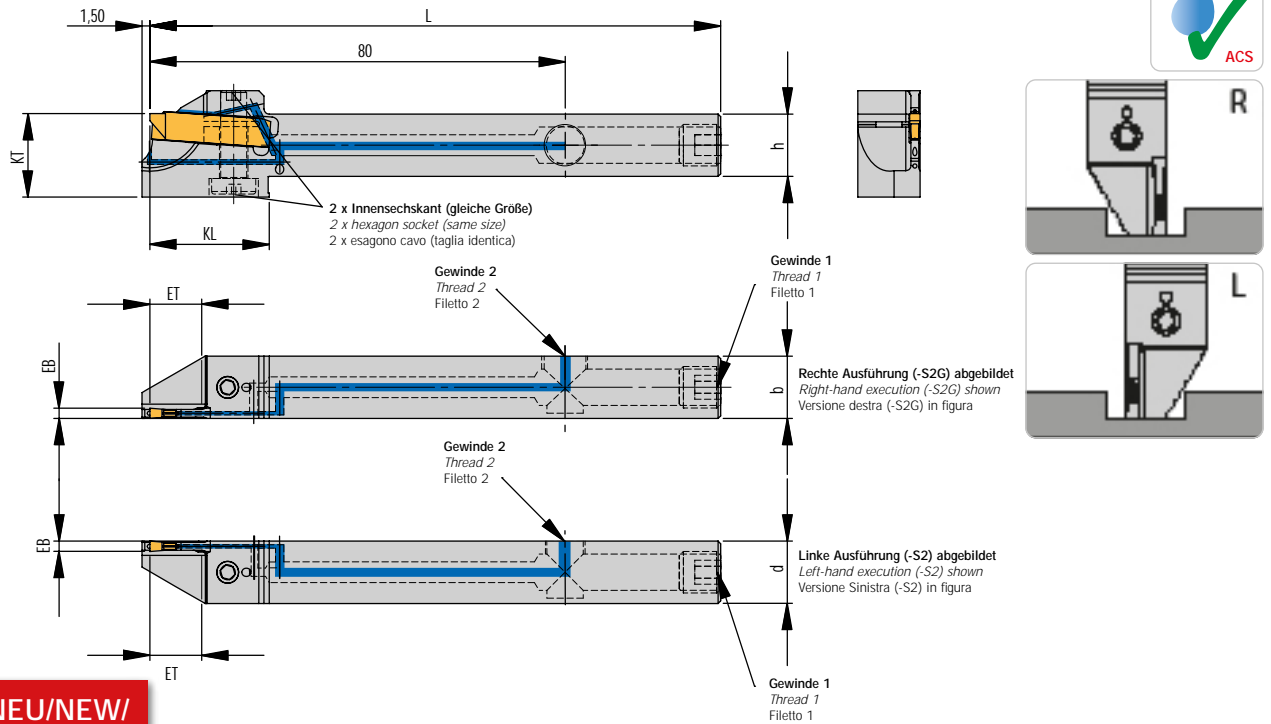

Trägerwerkzeuge / Holders / Utensili

Kühlmittelanschluss auf der Seite der Schneide / Coolant supply on the side of the cutting edge / Raccordo sul lato l'inserto

Artikel Article Articolo	EB	ET	D _{max}	D _R	h	b	L	L ₄	KL	KT	Gewinde 1 Thread 1 Filetto 1	Gewinde 2 Thread 2 Filetto 2	Schneideinsatz Insert Inserto
HSA 1616UD-L-SA2403-34-ACS2-H2-S2 N	3,0	17	34	-	16	16	110	30	30	29	G1/8"	G1/8"	SA24-30...
HSA 1616UD-R-SA2403-34-ACS2-H2-S2 N	3,0	17	34	-	16	16	110	30	30	29	G1/8"	G1/8"	SA24-30...

Trägerwerkzeuge / Holders / Utensili

Kühlmittelanschluss auf der gegenüberliegenden Seite der Schneide / Coolant supply on the opposite side of the cutting edge / Raccordo sul lato opposto l'inserto

Artikel Article Articolo	EB	ET	D _{max}	D _R	h	b	L	L ₄	KL	KT	Gewinde 1 Thread 1 Filetto 1	Gewinde 2 Thread 2 Filetto 2	Schneideinsatz Insert Inserto
HSA 1616UD-L-SA2403-34-ACS2-H2-S2G N	3,0	17	34	-	16	16	110	30	30	29	G1/8"	G1/8"	SA24-30...
HSA 1616UD-R-SA2403-34-ACS2-H2-S2G N	3,0	17	34	-	16	16	110	30	30	29	G1/8"	G1/8"	SA24-30...

Ersatzteile / Spare Parts / Ricambi

Trägerwerkzeug Holder Utensile	Schraube Screw Vite	Schlüssel Key Chiave
HSA 1616UD...SA2402-34-ACS2-H2-S2...	AS 0084	KP 3111

Zubehör / Accessories / Accessori

Bezeichnung Designation Articolo	A	B
KA 001 Kühlmittelanschluss – gerade Coolant supply – straight Raccordo – dritto	M8x1	Ø 6 mm
KA 002	1/8"	Ø 6 mm
KA 004 Kühlmittelanschluss – winklig, fest Coolant supply – angled and fixed Raccordo – angolato	M8x1	Ø 6 mm
KA 005	1/8"	Ø 6 mm
KA 006 Schwenkverschraubung Swivelling screw-fitting Raccordo – orientabile	M8x1	Ø 6 mm
KA 007	1/8"	Ø 6 mm

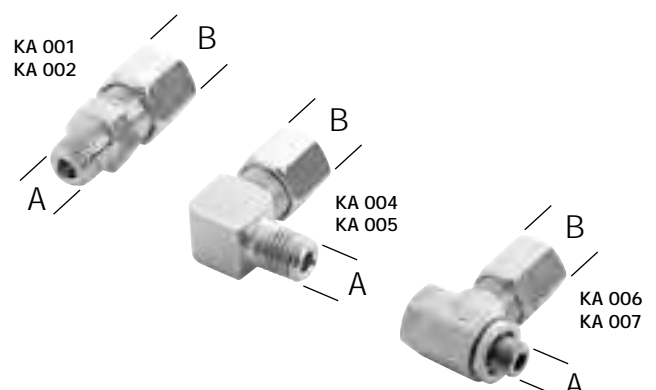

SA24

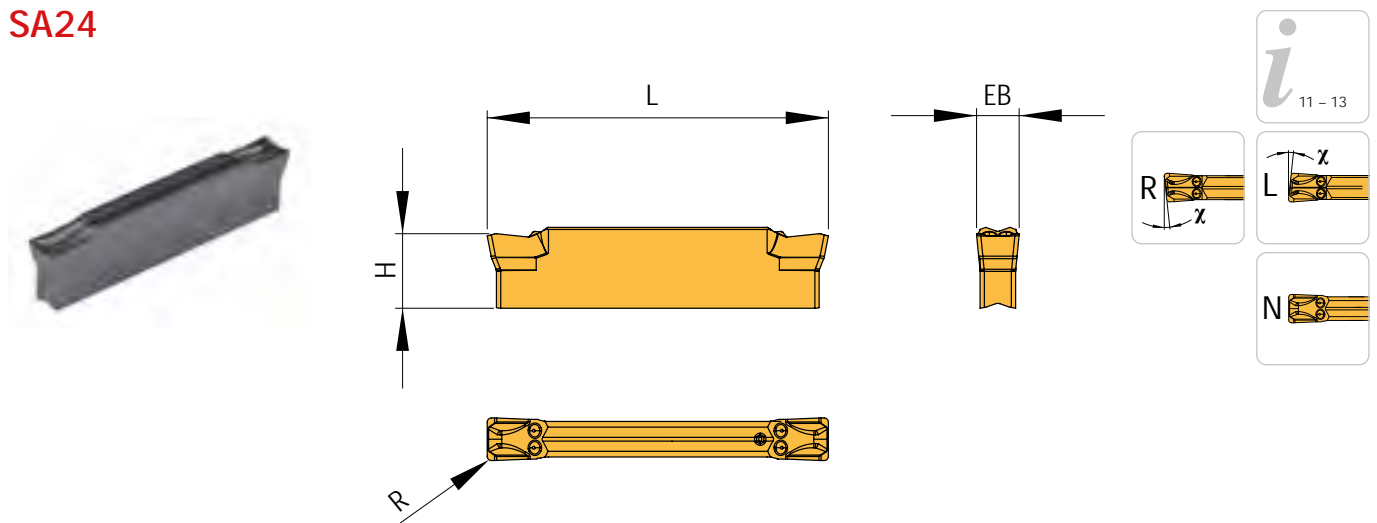

N NEU/NEW/
NUOVO

Gesinterte Ausführung / Sintered Execution / Esecuzione Sinterizzato

Artikel Article Articolo	EB ± 0,06	H	L	R	χ	beschichtet coated rivestito		
						AM5040	AP2240	AP5020
SA24-1502N-S1	1,5	5,5	24	0,2	0°	N		
SA24-1502N-T1	1,5	5,5	24	0,2	0°	N		N
SA24-1502R-S1	1,5	5,5	24	0,2	0°			◆
SA24-2002R-M1	2,0	5,5	24	0,2	0°			◆
SA24-2002R-S1	2,0	5,5	24	0,2	0°			◆
SA24-2002R-T1	2,0	5,5	24	0,2	0°			◆
SA24-2503N-M1	2,5	5,5	24	0,3	0°		◆	
SA24-2503N-S1	2,5	5,5	24	0,3	0°		◆	
SA24-2503N-T1	2,5	5,5	24	0,3	0°		◆	
SA24-2502R-M1	2,5	5,5	24	0,2	0°			◆
SA24-2502R-S1	2,5	5,5	24	0,2	6°	◆		◆
SA24-2502R-T1	2,5	5,5	24	0,2	6°			◆
SA24-3003L-S1	3,0	5,5	24	0,3	6°		◆	
SA24-3003R-M1	3,0	5,5	24	0,3	6°	◆		
SA24-3003R-S1	3,0	5,5	24	0,3	6°		◆	◆
SA24-3003R-T1	3,0	5,5	24	0,3	6°	◆	◆	

Hinweis: Bei linken und rechten Stechplatten muss ggf. das Trägerwerkzeug stirnseitig modifiziert werden.

Remark: When using left- or right-handed inserts the holder maybe needing modification.

Nota: Con l'utilizzo di inserti sinistrì o destrì può essere necessario modificare la lama.

P	○	●	●
M	●	○	○
K		●	
N			○
S			○
H			

● Hauptanwendung
Main application
Applicazione principale

○ Nebenanwendung
Secondary application
Applicazione secondaria

SA24

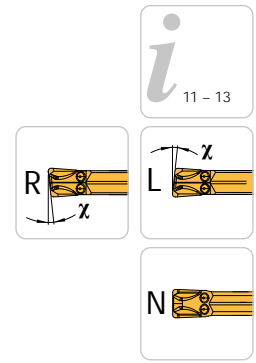
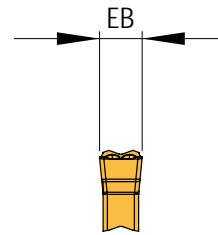
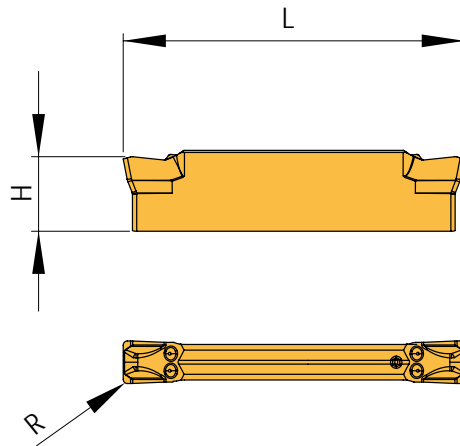

Geschliffene und verrundete Ausführung | Ground and rounded execution | Esecuzione rettificato e arrotondato

Artikel Article Articolo	EB ± 0,04	H	L	R	χ	AP5020	beschichtet coated rivestito
SA24-1500EL-S1-15G	1,5	5,5	24	0,0	15°	◆	
SA24-1500EN-S1-G	1,5	5,5	24	0,0	0°	◆	
SA24-1500ER-S1-8G	1,5	5,5	24	0,0	8°	◆	
SA24-1500ER-S1-15G	1,5	5,5	24	0,0	15°	◆	
SA24-1501R-S1-12	1,5	5,5	24	0,1	12°	◆	
SA24-2000EL-S1-15G	2,0	5,5	24	0,0	15°	◆	
SA24-2000EN-S1-G	2,0	5,5	24	0,0	0°	◆	
SA24-2000ER-S1-8G	2,0	5,5	24	0,0	8°	◆	
SA24-2000ER-S1-15G	2,0	5,5	24	0,0	15°	◆	
SA24-2001R-S1-12	2,0	5,5	24	0,1	12°	◆	
SA24-2500EL-S1-15G	2,5	5,5	24	0,0	15°	◆	
SA24-2500EN-S1-G	2,5	5,5	24	0,0	0°	◆	
SA24-2500ER-S1-8G	2,5	5,5	24	0,0	8°	◆	
SA24-2500ER-S1-15G	2,5	5,5	24	0,0	15°	◆	
SA24-2501R-S1-12	2,5	5,5	24	0,1	12°	◆	
SA24-3000EL-S1-15G	3,0	5,5	24	0,0	15°	◆	
SA24-3000EN-S1-G	3,0	5,5	24	0,0	0°	◆	
SA24-3000ER-S1-8G	3,0	5,5	24	0,0	8°	◆	
SA24-3000ER-S1-15G	3,0	5,5	24	0,0	15°	◆	
SA24-3002R-S1-12	3,0	5,5	24	0,2	12°	◆	

Hinweis: Bei linken und rechten Stechplatten muss ggf. das Trägerwerkzeug stirnseitig modifiziert werden.

Remark: When using left- or right-handed inserts the holder maybe needing modification.

Nota: Con l'utilizzo di inserti sinistri o destri può essere necessario modificare la lama.

P	●
M	○
K	○
N	○
S	○
H	

● Hauptanwendung
Main application
Applicazione principale

○ Nebenanwendung
Secondary application
Applicazione secondaria

SA35

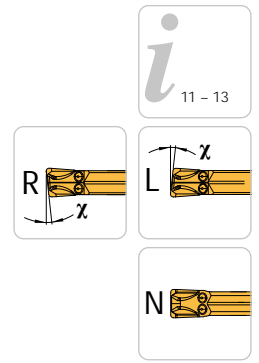
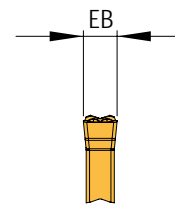
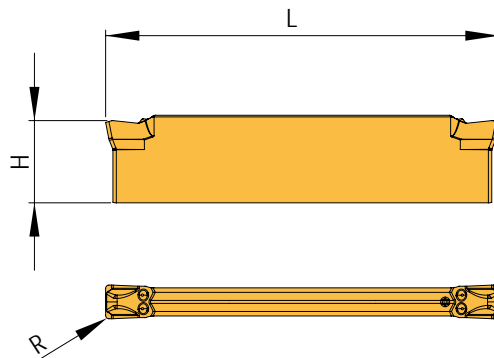

Gesinterte Ausführung / Sintered Execution / Esecuzione Sinterizzato

							beschichtet coated rivestito	
Artikel Article Articolo	EB - 0,04	H	L	R	χ	AM5040	AP5020	
SA35-3002L-S1-12	3	7,5	35	0,2	12°	◆	◆	

Hinweis: Bei linken und rechten Stechplatten muss ggf. das Trägerwerkzeug stirnseitig modifiziert werden.
 Remark: When using left- or right-handed inserts the holder maybe needing modification.
 Nota: Con l'utilizzo di inserti sinistri o destri può essere necessario modificare la lama.

P	○	●
M	●	○
K		
N		○
S		○
H		

● Hauptanwendung
Main application
Applicazione principale
○ Nebenanwendung
Secondary application
Applicazione secondaria

Werkstoff- gruppe	Gliederung der Werkstoffhauptgruppen und Kennbuchstaben		Brinell-Härte	Zugfestigkeit (N/mm ²)	Zerspanungsgruppe	Schnittgeschwindigkeit Vc (m/min)		
						beschichtet		
						AM5040	AP2240	AP5020
P	Unlegierter Stahl	C 0,25 % geglüht	125	428	P1	120 - 150 - 180	130 - 155 - 180	120 - 150 - 180
		C >= 0,25 ... >= 0,55 % geglüht	190	639	P2	80 - 115 - 150	110 - 145 - 180	80 - 115 - 150
		C >= 0,25 ... >= 0,55 % vergütet	210	708	P3	60 - 100 - 140	70 - 120 - 170	60 - 100 - 140
		C 0,55 % geglüht	190	639	P4	80 - 115 - 150	110 - 145 - 180	80 - 115 - 150
		C 0,55 % vergütet	300	1013	P5	60 - 100 - 140	70 - 120 - 170	60 - 100 - 140
		Automatenstahl (kurzspanend) geglüht	220	745	P6	80 - 115 - 150	110 - 145 - 180	80 - 115 - 150
	Niedrig legierter Stahl	geglüht	175	591	P7	80 - 120 - 160	120 - 150 - 180	80 - 125 - 170
		vergütet	300	1013	P8	60 - 95 - 130	110 - 145 - 180	60 - 95 - 130
		vergütet	380	1282	P9	60 - 95 - 130	110 - 145 - 180	60 - 95 - 130
		vergütet	430	1477	P10	60 - 90 - 120	70 - 110 - 150	60 - 90 - 120
	Hochlegierter Stahl und hochlegierter Werkzeugstahl	geglüht	200	675	P11	80 - 110 - 140	90 - 130 - 170	80 - 110 - 140
		gehärtet und angelassen	300	1013	P12	50 - 85 - 120	70 - 115 - 160	50 - 85 - 120
		gehärtet und angelassen	400	1361	P13	50 - 85 - 120	70 - 115 - 160	50 - 85 - 120
	Nichtrostender Stahl	ferretisch / martensitisch, geglüht	200	675	P14	60 - 110 - 160	120 - 150 - 180	60 - 115 - 170
		martensitisch, vergütet	330	1114	P15	50 - 75 - 100	60 - 80 - 100	50 - 75 - 100
austenitisch, abgeschreckt		200	675	M1	60 - 90 - 120	100 - 110 - 120	60 - 90 - 120	
M	Nichtrostender Stahl	austenitisch, ausscheidungsgehärtet (PH)	300	1013	M2	50 - 70 - 90	60 - 75 - 90	50 - 70 - 90
		austenitisch-ferritisch, Duplex	230	778	M3	40 - 60 - 80	40 - 60 - 80	50 - 70 - 90
		ferritisch	200	675	K1	-	100 - 150 - 200	-
K	Temperguss	perlitisch	260	867	K2	-	80 - 115 - 150	-
		niedrige Festigkeit	180	602	K3	-	100 - 150 - 200	-
	Grauguss	hohe Festigkeit / austenitisch	245	825	K4	-	90 - 135 - 180	-
		ferritisch	155	518	K5	-	100 - 130 - 160	-
	Gusseisen mit Kugelgraphit	perlitisch	265	885	K6	-	70 - 105 - 140	-
		GGV (CGI)	200	675	K7	-	100 - 150 - 200	-
	N	Aluminium-Knetlegierung	nicht aushärtbar	30	-	N1	-	-
aushärtbar, ausgehärtet			100	343	N2	-	-	100 - 200 - 300
Aluminium-Gusslegierung		12 % Si, nicht aushärtbar	75	260	N3	-	-	100 - 300 - 500
		12 % Si, aushärtbar, ausgehärtet	90	314	N4	-	-	100 - 200 - 300
		> 12 % Si, nicht aushärtbar	130	447	N5	-	-	100 - 150 - 200
Magnesiumlegierung			70	250	N6	-	-	-
Kupfer und Kupferlegierung (Bronze / Messing)		unlegiert, Elektrokupfer	100	343	N7	-	-	100 - 200 - 300
		Messing, Bronze, Rotguss	90	314	N8	-	-	100 - 300 - 500
		Cu-Legierung, kurzspanend	110	382	N9	-	-	100 - 200 - 300
		hochfest, Ampco	300	1013	N10	-	-	-
		Thermoplaste (ohne abrasive Füllstoffe)	-	-	N11	-	-	80 - 130 - 180
Nichtmetallische Werkstoffe		Duroplaste (ohne abrasive Füllstoffe)	-	-	N12	-	-	80 - 130 - 180
		Kunststoff glasfaserverstärkt GFRP	-	-	N13	-	-	60 - 105 - 150
		Kunststoff kohlefaserverstärkt CFRP	-	-	N14	-	-	60 - 105 - 150
		Kunststoff aramidfaserverstärkt AFRP	-	-	N15	-	-	60 - 105 - 150
		Graphit (technisch)	80 Shore	-	N16	-	-	-
	S	Warmfeste Legierungen	Fe-Basis geglüht	200	675	S1	-	-
Fe-Basis ausgehärtet			280	943	S2	-	-	20 - 30 - 40
Ni- oder Co-Basis geglüht			250	839	S3	-	-	15 - 20 - 25
Ni- oder Co-Basis ausgehärtet			350	1177	S4	-	-	10 - 15 - 20
Ni- oder Co-Basis gegossen			320	1076	S5	-	-	10 - 15 - 20
Titanlegierung		Reintitan	200	675	S6	-	-	50 - 85 - 120
		a- und B-Legierungen, ausgehärtet	375	1262	S7	-	-	30 - 40 - 50
		B-Legierungen	410	1396	S8	-	-	25 - 35 - 45
Wolframlegierungen			300	1013	S9	-	-	-
Molybdänlegierungen			300	1013	S10	-	-	-
H	Gehärteter Stahl	gehärtet und angelassen	50 HRC	-	H1	-	-	-
		gehärtet und angelassen	55 HRC	-	H2	-	-	-
		gehärtet und angelassen	60 HRC	-	H3	-	-	-
	Gehärtetes Gusseisen	gehärtet und angelassen	55 HRC	-	H4	-	-	-

Die Tabellenwerte sind Richtwerte.
Es kann notwendig sein, die Werte den jeweiligen Bearbeitungsbedingungen anzupassen.

Material group	Structure of the material groups and identification letters		Brinell hardness HB	Tensile strength Rm (N/mm ²)	Chipping group	Cutting speed Vc (m/min)		
						coated		
						AM5040	AP2240	AP5020
P	Unalloyed steel	C 0.25 % annealed	125	428	P1	120 - 150 - 180	130 - 155 - 180	120 - 150 - 180
		C >= 0,25 ... >= 0,55 % annealed	190	639	P2	80 - 115 - 150	110 - 145 - 180	80 - 115 - 150
		C >= 0,25 ... >= 0,55 % hardened and tempered	210	708	P3	60 - 100 - 140	70 - 120 - 170	60 - 100 - 140
		C 0.55 % annealed	190	639	P4	80 - 115 - 150	110 - 145 - 180	80 - 115 - 150
		C 0.55 % hardened and tempered	300	1013	P5	60 - 100 - 140	70 - 120 - 170	60 - 100 - 140
		Machining steel (short-clipping) annealed	220	745	P6	80 - 115 - 150	110 - 145 - 180	80 - 115 - 150
	Low alloyed steel	annealed	175	591	P7	80 - 120 - 160	120 - 150 - 180	80 - 125 - 170
		hardened and tempered	300	1013	P8	60 - 95 - 130	110 - 145 - 180	60 - 95 - 130
		hardened and tempered	380	1282	P9	60 - 95 - 130	110 - 145 - 180	60 - 95 - 130
		hardened and tempered	430	1477	P10	60 - 90 - 120	70 - 110 - 150	60 - 90 - 120
	High alloyed steel and high alloyed tool steel	annealed	200	675	P11	80 - 110 - 140	90 - 130 - 170	80 - 110 - 140
		hardened	300	1013	P12	50 - 85 - 120	70 - 115 - 160	50 - 85 - 120
		hardened	400	1361	P13	50 - 85 - 120	70 - 115 - 160	50 - 85 - 120
	Stainless steel	ferritic / martensitic, annealed	200	675	P14	60 - 110 - 160	120 - 150 - 180	60 - 115 - 170
		martensitic, hardened and tempered	330	1114	P15	50 - 75 - 100	60 - 80 - 100	50 - 75 - 100
hardened		400	1361	P13	50 - 85 - 120	70 - 115 - 160	50 - 85 - 120	
M	Stainless steel	austenitic, chilled	200	675	M1	60 - 90 - 120	100 - 110 - 120	60 - 90 - 120
		austenitic, precipitation-hardened (PH)	300	1013	M2	50 - 70 - 90	60 - 75 - 90	50 - 70 - 90
		austenitic-ferritic, Duplex	230	778	M3	40 - 60 - 80	40 - 60 - 80	50 - 70 - 90
K	Malleable cast iron	ferritic	200	675	K1	-	100 - 150 - 200	-
		pearlitic	260	867	K2	-	80 - 115 - 150	-
	Cast iron	low tensile strength	180	602	K3	-	100 - 150 - 200	-
		high tensile strength / austenitic	245	825	K4	-	90 - 135 - 180	-
	Cast iron with nodular graphite	ferritic	155	518	K5	-	100 - 130 - 160	-
		pearlitic	265	885	K6	-	70 - 105 - 140	-
	GGV (CGI)		200	675	K7	-	100 - 150 - 200	-
N	Aluminium alloys long chipping	not heat treatable	30	-	N1	-	-	100 - 300 - 500
		heat treatable, heat treated	100	343	N2	-	-	100 - 200 - 300
	Casted aluminium alloys	12 % Si, not heat treatable	75	260	N3	-	-	100 - 300 - 500
		12 % Si, heat treatable, heat treated	90	314	N4	-	-	100 - 200 - 300
	Magnesium alloys		130	447	N5	-	-	100 - 150 - 200
			70	250	N6	-	-	-
	Copper and copper alloys (Brass / Bronze)	Unalloyed, electrolyte copper	100	343	N7	-	-	100 - 200 - 300
		Brass, Bronze	90	314	N8	-	-	100 - 300 - 500
		Cu-alloys, short-chipping	110	382	N9	-	-	100 - 200 - 300
			300	1013	N10	-	-	-
	Non-ferrous materials	Lead alloys (without abrasive filling material)	-	-	N11	-	-	80 - 130 - 180
		Duroplastic (without abrasive filling material)	-	-	N12	-	-	80 - 130 - 180
		Plastic glas fibre reinforced GFRP	-	-	N13	-	-	60 - 105 - 150
		Plastic carbon fibre reinforced CFRP	-	-	N14	-	-	60 - 105 - 150
		Plastic aramid fibre reinforced AFRP	-	-	N15	-	-	60 - 105 - 150
		Graphite (tech.)	80 Shore	-	N16	-	-	-
S	High temperature resistant alloys	Fe-based annealed	200	675	S1	-	-	20 - 35 - 50
		Fe-based heat treated	280	943	S2	-	-	20 - 30 - 40
		Ni- or Co-alloyed annealed	250	839	S3	-	-	15 - 20 - 25
		Ni- or Co-alloyed heat treated	350	1177	S4	-	-	10 - 15 - 20
		Ni- or Co-alloyed casting	320	1076	S5	-	-	10 - 15 - 20
	Titanium alloys	Pure titan	200	675	S6	-	-	50 - 85 - 120
		- and -alloys, heat treated	375	1262	S7	-	-	30 - 40 - 50
		-alloys	410	1396	S8	-	-	25 - 35 - 45
	Wolfram alloys		300	1013	S9	-	-	-
	Molybdän alloys		300	1013	S10	-	-	-
H	Hardened steel	hardened	50 HRC	-	H1	-	-	-
		hardened	55 HRC	-	H2	-	-	-
		hardened	60 HRC	-	H3	-	-	-
	Hardened cast iron	hardened	55 HRC	-	H4	-	-	-

The recommended cutting data are only approximate values. It may be necessary to adjust them to each individual machining application.

Gruppo materiale	Struttura dei gruppi di materiali e lettere di riferimento		Durezza Brinell	Resistenza Rm (N/mm ²)	Gruppo di lavoro	Velocità di taglio Vc (m/min)		
						rivestito		
						AM5040	AP2240	AP5020
P	Acciai non legato	C 0,25 % ricotto	125	428	P1	120 - 150 - 180	130 - 155 - 180	120 - 150 - 180
		C >= 0,25 ... >= 0,55 % ricotto	190	639	P2	80 - 115 - 150	110 - 145 - 180	80 - 115 - 150
		C >= 0,25 ... >= 0,55 % bonificato	210	708	P3	60 - 100 - 140	70 - 120 - 170	60 - 100 - 140
		C 0,55 % ricotto	190	639	P4	80 - 115 - 150	110 - 145 - 180	80 - 115 - 150
		C 0,55 % bonificato	300	1013	P5	60 - 100 - 140	70 - 120 - 170	60 - 100 - 140
	Acciai debolmente legati	Acciaio (truciolo corto) ricotto	220	745	P6	80 - 115 - 150	110 - 145 - 180	80 - 115 - 150
		ricotto	175	591	P7	80 - 120 - 160	120 - 150 - 180	80 - 125 - 170
		bonificato	300	1013	P8	60 - 95 - 130	110 - 145 - 180	60 - 95 - 130
		bonificato	380	1282	P9	60 - 95 - 130	110 - 145 - 180	60 - 95 - 130
		bonificato	430	1477	P10	60 - 90 - 120	70 - 110 - 150	60 - 90 - 120
	Acciai fortemente legati e acciai da utensili	ricotto	200	675	P11	80 - 110 - 140	90 - 130 - 170	80 - 110 - 140
		temprato e rinvenuto	300	1013	P12	50 - 85 - 120	70 - 115 - 160	50 - 85 - 120
		temprato e rinvenuto	400	1361	P13	50 - 85 - 120	70 - 115 - 160	50 - 85 - 120
	Acciai inossidabili	ferritico / martensitico, ricotto	200	675	P14	60 - 110 - 160	120 - 150 - 180	60 - 115 - 170
		martensitico, bonificato	330	1114	P15	50 - 75 - 100	60 - 80 - 100	50 - 75 - 100
M	Acciai inossidabili	austenitico, trattato o temperato	200	675	M1	60 - 90 - 120	100 - 110 - 120	60 - 90 - 120
		austenitico, indurimento per precipitazione (PH)	300	1013	M2	50 - 70 - 90	60 - 75 - 90	50 - 70 - 90
		austenitico-ferritico, Duplex	230	778	M3	40 - 60 - 80	40 - 60 - 80	50 - 70 - 90
K	Ghisa temprata	ferritico	200	675	K1	-	100 - 150 - 200	-
		perlitica	260	867	K2	-	80 - 115 - 150	-
	Ghisa grigia	bassa resistenza	180	602	K3	-	100 - 150 - 200	-
		alta resistenza / austenitico	245	825	K4	-	90 - 135 - 180	-
	Ghisa sferoidale	ferritico	155	518	K5	-	100 - 130 - 160	-
		perlitica	265	885	K6	-	70 - 105 - 140	-
	GGV (CGI)		200	675	K7	-	100 - 150 - 200	-
N	Leghe di Alluminio stampato	non invecchiato	30	-	N1	-	-	100 - 300 - 500
		rinvenuto, invecchiato	100	343	N2	-	-	100 - 200 - 300
	Leghe di Alluminio da fusione	12 % Si, non invecchiato	75	260	N3	-	-	100 - 300 - 500
		12 % Si, rinvenuto, invecchiato	90	314	N4	-	-	100 - 200 - 300
	Leghe di magnesio		130	447	N5	-	-	100 - 150 - 200
			70	250	N6	-	-	-
	Rame e Leghe di Rame (Bronzo / Ottone)	Non legati, Rame Elettrolitico	100	343	N7	-	-	100 - 200 - 300
		Ottone, Bronzo	90	314	N8	-	-	100 - 300 - 500
		Leghe Cu, truciolo corto	110	382	N9	-	-	100 - 200 - 300
			300	1013	N10	-	-	-
	Materiali non metallici	Leghe al piombo (senza materiale di riempimento abrasivo)	-	-	N11	-	-	80 - 130 - 180
		Duroplastico (senza materiale di riempimento abrasivo)	-	-	N12	-	-	80 - 130 - 180
		Plastica rinforzata in fibra di vetro GFRP	-	-	N13	-	-	60 - 105 - 150
		Plastica rinforzata in fibra di carbonio CFRP	-	-	N14	-	-	60 - 105 - 150
		Plastica rinforzata in fibra aramidica AFRP	-	-	N15	-	-	60 - 105 - 150
		Grafite (tecnico)	80 Shore	-	N16	-	-	-
S	Leghe resistenti al calore	Base-Fe ricotto	200	675	S1	-	-	20 - 35 - 50
		Base-Fe invecchiato	280	943	S2	-	-	20 - 30 - 40
		Base Ni o Co ricotto	250	839	S3	-	-	15 - 20 - 25
		Base Ni o Co invecchiato	350	1177	S4	-	-	10 - 15 - 20
		Base Ni o Co da fusione	320	1076	S5	-	-	10 - 15 - 20
	Leghe di Titanio	Titanio puro	200	675	S6	-	-	50 - 85 - 120
		Leghe e , invecchiato	375	1262	S7	-	-	30 - 40 - 50
		Leghe	410	1396	S8	-	-	25 - 35 - 45
	Leghe di tungsteno		300	1013	S9	-	-	-
	Leghe di molibdeno		300	1013	S10	-	-	-
H	Acciaio Temprato	temprato e rinvenuto	50 HRC	-	H1	-	-	-
		temprato e rinvenuto	55 HRC	-	H2	-	-	-
		temprato e rinvenuto	60 HRC	-	H3	-	-	-
	Ghisa Temprata	temprato e rinvenuto	55 HRC	-	H4	-	-	-

I dati indicati in tabella sono valori approssimati.
Può essere necessario adattarli alle singole applicazioni di lavorazione.

Inserts
Inserti

SE24

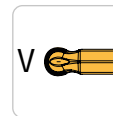
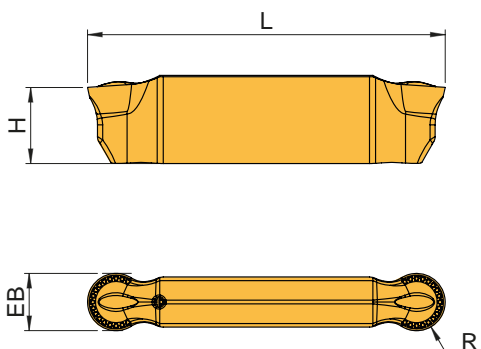

Gesinterte Ausführung / Sintered Execution / Esecuzione Sinterizzato

Artikel Article Articolo	EB ± 0,04	H	L	R	AP5020	beschichtet coated rivestito
SE24-2010N-RP1	2	5,5	24	1,0	◆	
SE24-3015N-RP1	3	5,5	24	1,5	◆	
SE24-4020N-RP1	4	5,5	24	2,0	◆	
SE24-5025N-RP1	5	7,5	24	2,5	◆	
SE24-6030N-RP1	6	7,5	24	3,0	◆	

P	●
M	○
K	
N	○
S	○
H	

● Hauptanwendung
Main application
Applicazione principale
○ Nebenanwendung
Secondary application
Applicazione secondaria

Werkstoffgruppe	Gliederung der Werkstoffhauptgruppen und Kennbuchstaben		Brinell-Härte	Zugfestigkeit (N/mm ²)	Zerspanungsgruppe	Schnittgeschwindigkeit Vc (m/min)
						beschichtet
						AP5020
P	Unlegierter Stahl	C 0,25 % geglüht	125	428	P1	120 - 150 - 180
		C >= 0,25 ... >= 0,55 % geglüht	190	639	P2	80 - 115 - 150
		C >= 0,25 ... >= 0,55 % vergütet	210	708	P3	60 - 100 - 140
		C 0,55 % geglüht	190	639	P4	80 - 115 - 150
		C 0,55 % vergütet	300	1013	P5	60 - 100 - 140
		Automatenstahl (kurzspanend) geglüht	220	745	P6	80 - 115 - 150
	Niedrig legierter Stahl	geglüht	175	591	P7	80 - 125 - 170
		vergütet	300	1013	P8	60 - 95 - 130
		vergütet	380	1282	P9	60 - 95 - 130
		vergütet	430	1477	P10	60 - 90 - 120
	Hochlegierter Stahl und hochlegierter Werkzeugstahl	geglüht	200	675	P11	80 - 110 - 140
		gehärtet und angelassen	300	1013	P12	50 - 85 - 120
		gehärtet und angelassen	400	1361	P13	50 - 85 - 120
	Nichtrostender Stahl	ferritisch / martensitisch, geglüht	200	675	P14	60 - 115 - 170
martensitisch, vergütet		330	1114	P15	50 - 75 - 100	
M	Nichtrostender Stahl	austenitisch, abgeschreckt	200	675	M1	60 - 90 - 120
		austenitisch, ausscheidungsgehärtet (PH)	300	1013	M2	50 - 70 - 90
		austenitisch-ferritisch, Duplex	230	778	M3	50 - 70 - 90
K	Temperguss	ferritisch	200	675	K1	-
		perlitisch	260	867	K2	-
	Grauguss	niedrige Festigkeit	180	602	K3	-
		hohe Festigkeit / austenitisch	245	825	K4	-
	Gusseisen mit Kugelgraphit	ferritisch	155	518	K5	-
		perlitisch	265	885	K6	-
	GGV (CGI)		200	675	K7	-
N	Aluminium-Knetlegierung	nicht aushärtbar	30	-	N1	100 - 300 - 500
		aushärtbar, ausgehärtet	100	343	N2	100 - 200 - 300
	Aluminium-Gusslegierung	12 % Si, nicht aushärtbar	75	260	N3	100 - 300 - 500
		12 % Si, aushärtbar, ausgehärtet	90	314	N4	100 - 200 - 300
		> 12 % Si, nicht aushärtbar	130	447	N5	100 - 150 - 200
	Magnesiumlegierung		70	250	N6	-
	Kupfer und Kupferlegierung (Bronze / Messing)	unlegiert, Elektrolytkupfer	100	343	N7	100 - 200 - 300
		Messing, Bronze, Rotguss	90	314	N8	100 - 300 - 500
		Cu-Legierung, kurzspanend	110	382	N9	100 - 200 - 300
		hochfest, Ampco	300	1013	N10	-
	Nichtmetallische Werkstoffe	Thermoplaste (ohne abrasive Füllstoffe)	-	-	N11	80 - 130 - 180
		Duroplaste (ohne abrasive Füllstoffe)	-	-	N12	80 - 130 - 180
		Kunststoff glasfaserverstärkt GFRP	-	-	N13	60 - 105 - 150
		Kunststoff kohlefaserverstärkt CFRP	-	-	N14	60 - 105 - 150
		Kunststoff aramidfaserverstärkt AFRP	-	-	N15	60 - 105 - 150
		Graphit (technisch)	80 Shore	-	N16	-
S	Warmfeste Legierungen	Fe-Basis geglüht	200	675	S1	20 - 35 - 50
		Fe-Basis ausgehärtet	280	943	S2	20 - 30 - 40
		Ni- oder Co-Basis geglüht	250	839	S3	15 - 20 - 25
		Ni- oder Co-Basis ausgehärtet	350	1177	S4	10 - 15 - 20
		Ni- oder Co-Basis gegossen	320	1076	S5	10 - 15 - 20
	Titanlegierung	Reintitan	200	675	S6	50 - 85 - 120
		a- und β-Legierungen, ausgehärtet	375	1262	S7	30 - 40 - 50
		β-Legierungen	410	1396	S8	25 - 35 - 45
	Wolframlegierungen		300	1013	S9	-
	Molybdänlegierungen		300	1013	S10	-
H	Gehärteter Stahl	gehärtet und angelassen	50 HRC	-	H1	-
		gehärtet und angelassen	55 HRC	-	H2	-
		gehärtet und angelassen	60 HRC	-	H3	-
	Gehärtetes Gusseisen	gehärtet und angelassen	55 HRC	-	H4	-

Die Tabellenwerte sind Richtwerte.
Es kann notwendig sein, die Werte den jeweiligen Bearbeitungsumständen anzupassen.

Material group	Structure of the material groups and identification letters		Brinell hardness HB	Tensile strength Rm (N/mm ²)	Chipping group	Cutting speed Vc (m/min)	
						coated	
						AP5020	
P	Unalloyed steel	C 0.25 % annealed	125	428	P1	120 - 150 - 180	
		C >= 0.25 ... >= 0.55 % annealed	190	639	P2	80 - 115 - 150	
		C >= 0.25 ... >= 0.55 % hardened and tempered	210	708	P3	60 - 100 - 140	
		C 0.55 % annealed	190	639	P4	80 - 115 - 150	
		C 0.55 % hardened and tempered	300	1013	P5	60 - 100 - 140	
		Machining steel (short-chipping) annealed	220	745	P6	80 - 115 - 150	
	Low alloyed steel	annealed	175	591	P7	80 - 125 - 170	
		hardened and tempered	300	1013	P8	60 - 95 - 130	
		hardened and tempered	380	1282	P9	60 - 95 - 130	
		hardened and tempered	430	1477	P10	60 - 90 - 120	
	High alloyed steel and high alloyed tool steel	annealed	200	675	P11	80 - 110 - 140	
		hardened	300	1013	P12	50 - 85 - 120	
		hardened	400	1361	P13	50 - 85 - 120	
	Stainless steel	ferretic / martensitic, annealed	200	675	P14	60 - 115 - 170	
		martensitic, hardened and tempered	330	1114	P15	50 - 75 - 100	
M	Stainless steel	austenitic, chilled	200	675	M1	60 - 90 - 120	
		austenitic, precipitation-hardened (PH)	300	1013	M2	50 - 70 - 90	
		austenitic-ferritic, Duplex	230	778	M3	50 - 70 - 90	
		pearlitic	200	675	K1	-	
K	Malleable cast iron	pearlitic	260	867	K2	-	
		low tensile strength	180	602	K3	-	
	Cast iron	high tensile strength / austenitic	245	825	K4	-	
		ferretic	155	518	K5	-	
	Cast iron with nodular graphite	pearlitic	265	885	K6	-	
	GGV (CGI)		200	675	K7	-	
	N	Aluminium alloys long chipping	not heat treatable	30	-	N1	100 - 300 - 500
heat treatable, heat treated			100	343	N2	100 - 200 - 300	
Casted aluminium alloys		12 % Si, not heat treatable	75	260	N3	100 - 300 - 500	
		12 % Si, heat treatable, heat treated	90	314	N4	100 - 200 - 300	
Magnesium alloys			130	447	N5	100 - 150 - 200	
			70	250	N6	-	
Copper and copper alloys (Brass / Bronze)		Unalloyed, elektrolyte copper	100	343	N7	100 - 200 - 300	
		Brass, Bronze	90	314	N8	100 - 300 - 500	
		Cu-alloys, short-chipping	110	382	N9	100 - 200 - 300	
			300	1013	N10	-	
Non-ferrous materials		Lead alloys (without abrasive filling material)	-	-	N11	80 - 130 - 180	
		Duroplastic (without abrasive filling material)	-	-	N12	80 - 130 - 180	
		Plastic glas fibre reinforced GFRP	-	-	N13	60 - 105 - 150	
		Plastic carbon fibre reinforced CFRP	-	-	N14	60 - 105 - 150	
		Plastic aramid fibre reinforced AFRP	-	-	N15	60 - 105 - 150	
	Graphite (tech.)	80 Shore	-	N16	-		
S	High temperature resistant alloys	Fe-based annealed	200	675	S1	20 - 35 - 50	
		Fe-based heat treated	280	943	S2	20 - 30 - 40	
		Ni- or Co-alloyed annealed	250	839	S3	15 - 20 - 25	
		Ni- or Co-alloyed heat treated	350	1177	S4	10 - 15 - 20	
		Ni- or Co-alloyed casting	320	1076	S5	10 - 15 - 20	
	Titanium alloys	Pure titan	200	675	S6	50 - 85 - 120	
		- and -alloys, heat treated	375	1262	S7	30 - 40 - 50	
		-alloys	410	1396	S8	25 - 35 - 45	
	Wolfram alloys		300	1013	S9	-	
	Molybdän alloys		300	1013	S10	-	
H	Hardened steel	hardened	50 HRC	-	H1	-	
		hardened	55 HRC	-	H2	-	
		hardened	60 HRC	-	H3	-	
	Hardened cast iron	hardened	55 HRC	-	H4	-	

The recommended cutting data are only approximate values.
It may be necessary to adjust them to each individual machining application.

Gruppo materiale	Struttura dei gruppi di materiali e lettere di riferimento		Durezza Brinell	Resistenza Rm (N/mm ²)	Gruppo di lavoro	Velocità di taglio Vc (m/min)
						rivestito
						AP5020
P	Acciai non legato	C 0,25 % ricotto	125	428	P1	120 - 150 - 180
		C >= 0,25 ... >= 0,55 % ricotto	190	639	P2	80 - 115 - 150
		C >= 0,25 ... >= 0,55 % bonificato	210	708	P3	60 - 100 - 140
		C 0,55 % ricotto	190	639	P4	80 - 115 - 150
		C 0,55 % bonificato	300	1013	P5	60 - 100 - 140
	Acciai debolmente legati	Acciaio (truciolo corto) ricotto	220	745	P6	80 - 115 - 150
		ricotto	175	591	P7	80 - 125 - 170
		bonificato	300	1013	P8	60 - 95 - 130
		bonificato	380	1282	P9	60 - 95 - 130
		bonificato	430	1477	P10	60 - 90 - 120
	Acciai fortemente legati e acciai da utensili	ricotto	200	675	P11	80 - 110 - 140
		temprato e rinvenuto	300	1013	P12	50 - 85 - 120
		temprato e rinvenuto	400	1361	P13	50 - 85 - 120
	Acciai inossidabili	ferritico / martensitico, ricotto	200	675	P14	60 - 115 - 170
		martensitico, bonificato	330	1114	P15	50 - 75 - 100
austenitico, trattato o temperato		200	675	M1	60 - 90 - 120	
M	Acciai inossidabili	austenitico, indurimento per precipitazione (PH)	300	1013	M2	50 - 70 - 90
		austenitico-ferritico, Duplex	230	778	M3	50 - 70 - 90
		ferritico	200	675	K1	-
K	Ghisa temprata	perlitica	260	867	K2	-
		bassa resistenza	180	602	K3	-
	Ghisa grigia	alta resistenza / austenitico	245	825	K4	-
		ferritico	155	518	K5	-
	Ghisa sferoidale	perlitica	265	885	K6	-
GGV (CGI)		200	675	K7	-	
N	Leghe di Alluminio stampato	non invecchiato	30	-	N1	100 - 300 - 500
		rinvenuto, invecchiato	100	343	N2	100 - 200 - 300
	Leghe di Alluminio da fusione	12 % Si, non invecchiato	75	260	N3	100 - 300 - 500
		12 % Si, rinvenuto, invecchiato	90	314	N4	100 - 200 - 300
	Leghe di magnesio		130	447	N5	100 - 150 - 200
			70	250	N6	-
	Rame e Leghe di Rame (Bronzo / Ottone)	Non legati, Rame Elettrolitico	100	343	N7	100 - 200 - 300
		Ottone, Bronzo	90	314	N8	100 - 300 - 500
		Leghe Cu, truciolo corto	110	382	N9	100 - 200 - 300
			300	1013	N10	-
	Materiali non metallici	Leghe al piombo (senza materiale di riempimento abrasivo)	-	-	N11	80 - 130 - 180
		Duroplastico (senza materiale di riempimento abrasivo)	-	-	N12	80 - 130 - 180
		Plastica rinforzata in fibra di vetro GFRP	-	-	N13	60 - 105 - 150
		Plastica rinforzata in fibra di carbonio CFRP	-	-	N14	60 - 105 - 150
		Plastica rinforzata in fibra aramidica AFRP	-	-	N15	60 - 105 - 150
		Grafite (tecnico)	80 Shore	-	N16	-
S	Leghe resistenti al calore	Base-Fe ricotto	200	675	S1	20 - 35 - 50
		Base-Fe invecchiato	280	943	S2	20 - 30 - 40
		Base Ni o Co ricotto	250	839	S3	15 - 20 - 25
		Base Ni o Co invecchiato	350	1177	S4	10 - 15 - 20
		Base Ni o Co da fusione	320	1076	S5	10 - 15 - 20
	Leghe di Titanio	Titanio puro	200	675	S6	50 - 85 - 120
		Leghe e , invecchiato	375	1262	S7	30 - 40 - 50
	Leghe di tungsteno	Leghe	410	1396	S8	25 - 35 - 45
	Leghe di molibdeno		300	1013	S9	-
			300	1013	S10	-
H	Acciaio Temprato	temprato e rinvenuto	50 HRC	-	H1	-
		temprato e rinvenuto	55 HRC	-	H2	-
		temprato e rinvenuto	60 HRC	-	H3	-
	Ghisa Temprata	temprato e rinvenuto	55 HRC	-	H4	-

I dati indicati in tabella sono valori approssimati. Può essere necessario adattarli alle singole applicazioni di lavorazione.

Holders with screw clamping
 Steli con fissaggio a vite

SCLD L/R

Anstellwinkel 95° / Approach angle 95° / Angolo di attacco 95°

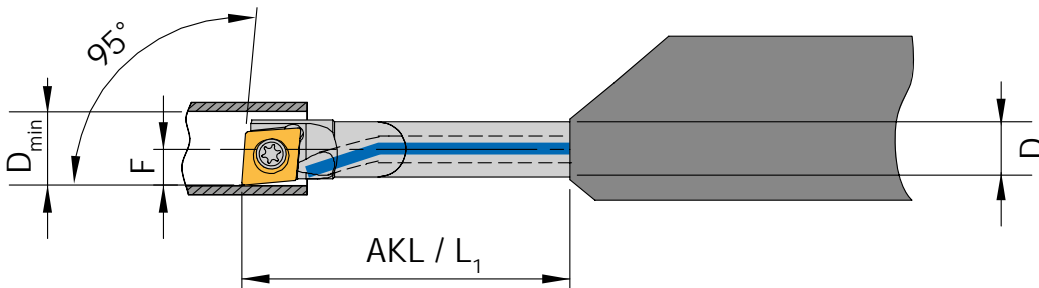
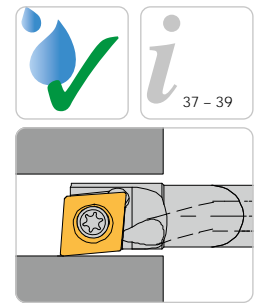

Rechte Ausführung abgebildet
 Right-hand execution shown
 Versione destra in figura

Trägerwerkzeuge / Holders / Utensili

AMS-Bohrstangen - mit innerer Kühlmittelzufuhr / AMS boring bar - with through tool coolant / Bareno AMS - con adduzione interna del refrigerante

Bezeichnung Designation Articolo	D _{min}	AKL	F	L ₁	D	Schneideinsatz Insert Inserto
E04-SCLDL/R04-AMS	4,8	24,0	2,4	24,0	4	CD.. 040102...
E06-SCLDL/R04-AMS	6,8	37,7	3,4	37,7	6	CD.. 040102...

Ersatzteile / Spare Parts / Ricambi

Trägerwerkzeug Holder Utensile	Schraube Screw Vite	Schlüssel Key Chiave
E...SCLDL/R04-AMS	T1,8.03	KS 1886

Holders with screw clamping
 Steli con fissaggio a vite

SDQC L/R

Anstellwinkel 107,5° / Approach angle 107,5° / Angolo di attacco 107,5°

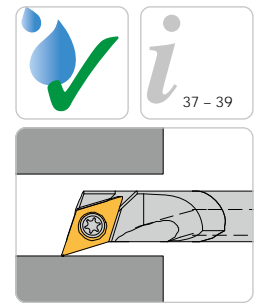
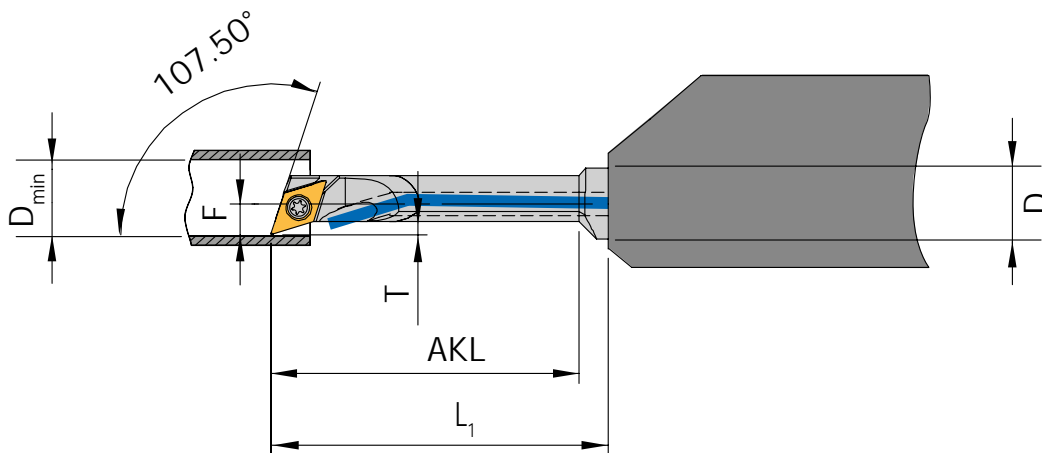

Rechte Ausführung abgebildet
 Right-hand execution shown
 Versione destra in figura

Trägerwerkzeuge / Holders / Utensili

AMS-Bohrstangen - mit innerer Kühlmittelzufuhr / AMS boring bar - with through tool coolant / Bareno AMS - con adduzione interna del refrigerante

Bezeichnung Designation Articolo	D _{min}	AKL	T	F	L ₁	D	Schneideinsatz Insert Inserto
E0406-SDQCL/R04-AMS	5,2	26	1,1	2,6	28,5	6	DC.. 04T0...
E0408-SDQCL/R04-AMS	5,2	26	1,1	2,6	29,5	8	DC.. 04T0...

Ersatzteile / Spare Parts / Ricambi

Trägerwerkzeug Holder Utensile	Schraube Screw Vite	Schlüssel Key Chiave
E04..-SDQCL/R04-AMS	AS 0112	KS 2505

Holders with screw clamping
 Steli con fissaggio a vite

SDUC L/R

Anstellwinkel 93° / Approach angle 93° / Angolo di attacco 93°

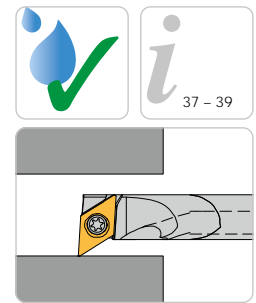

Rechte Ausführung abgebildet
 Right-hand execution shown
 Versione destra in figura

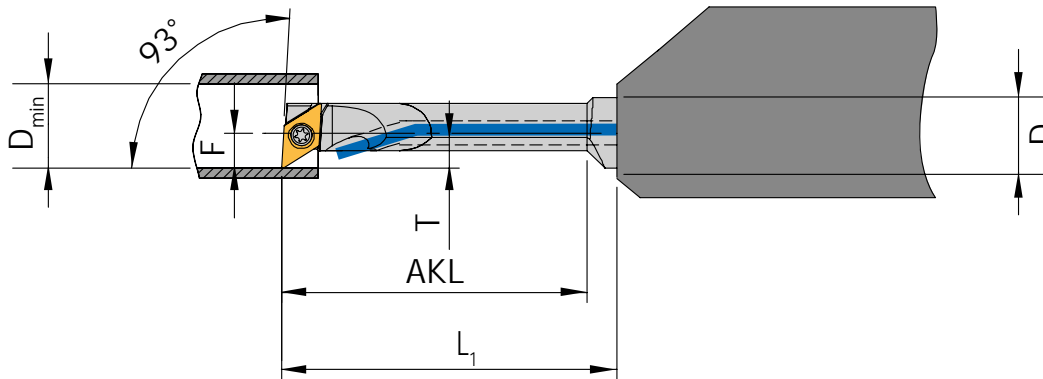

Trägerwerkzeuge / Holders / Utensili

AMS-Bohrstangen - mit innerer Kühlmittelzufuhr / AMS boring bar - with through tool coolant / Bareno AMS - con adduzione interna del refrigerante

Bezeichnung Designation Articolo	D _{min}	AKL	T	F	L ₁	D	Schneideinsatz Inserto Inserto
E0406-SDUCL/R04-AMS	5,6	26	1,5	3	28,5	6	DC.. 04TO...
E0408-SDUCL/R04-AMS	5,6	26	1,5	3	29,5	8	DC.. 04TO...

Ersatzteile / Spare Parts / Ricambi

Trägerwerkzeug Holder Utensile	Schraube Screw Vite	Schlüssel Key Chiave
E04.-SDUCL/R04-AMS	AS 0112	KS 2505

Holders with screw clamping
 Steli con fissaggio a vite

SV95C L/R

Anstellwinkel 95° / Approach angle 95° / Angolo di attacco 95°

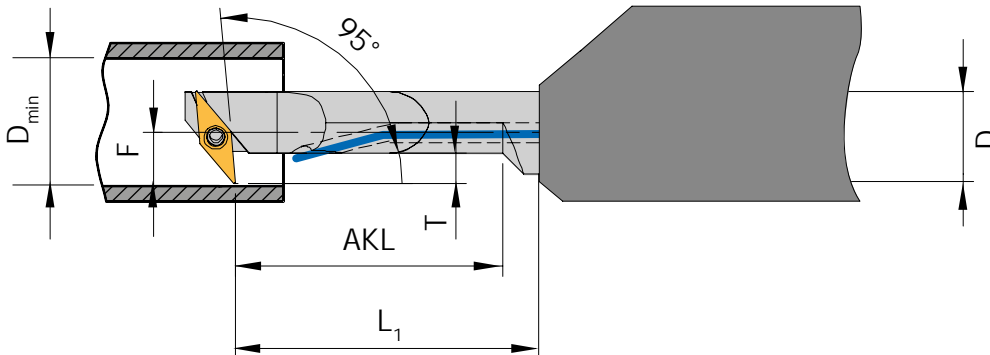
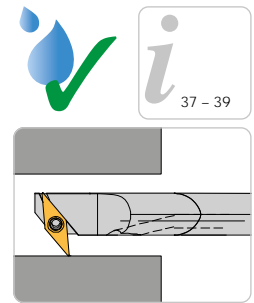

Rechte Ausführung abgebildet
 Right-hand execution shown
 Versione destra in figura



Trägerwerkzeuge / Holders / Utensili

AMS-Bohrstangen - mit innerer Kühlmittelzufuhr / AMS boring bar - with through tool coolant / Bareno AMS - con adduzione interna del refrigerante

Bezeichnung Designation Articolo	D _{min}	AKL	T	F	L ₁	D	Schneideinsatz Insert Inserto
E0406-SV95CL/R05-AMS N	9,5	26	4,5	6	28	6	VC.. 0501...
E0408-SV95CL/R05-AMS N	9,5	26	3,0	5	29	8	VC.. 0501...

Ersatzteile / Spare Parts / Ricambi

Trägerwerkzeug Holder Utensile	Schraube Screw Vite	Schlüssel Key Chiave
E04.-SV95CL/R05-AMS	AS 0112	KS 2505

Holders with screw clamping
 Steli con fissaggio a vite

SVJC L/R

Anstellwinkel 52° / Approach angle 52° / Angolo di attacco 52°

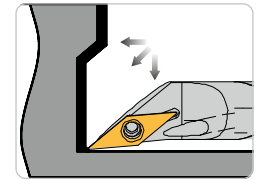
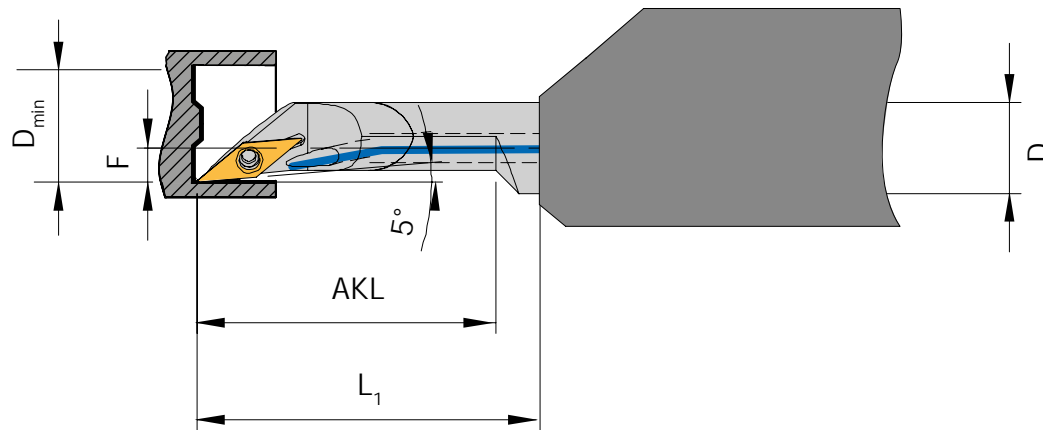

Rechte Ausführung abgebildet
 Right-hand execution shown
 Versione destra in figura



Trägerwerkzeuge / Holders / Utensili

AMS-Bohrstangen - mit innerer Kühlmittelzufuhr / AMS boring bar - with through tool coolant / Bareno AMS - con adduzione interna del refrigerante

Bezeichnung Designation Articolo	D _{min}	AKL	F	L ₁	D	Schneideinsatz Insert Inserto
E0406-SVJCL/R05-AMS N	5,5	26	2	28	6	VC.. 0501...
E0408-SVJCL/R05-AMS N	5,5	26	2	29	8	VC.. 0501...

Ersatzteile / Spare Parts / Ricambi

Trägerwerkzeug Holder Utensile	Schraube Screw Vite	Schlüssel Key Chiave
E04.-SVJCL/R05-AMS	AS 0112	KS 2505

Holders with screw clamping
 Steli con fissaggio a vite

SVLC L/R

Anstellwinkel 95° / Approach angle 95° / Angolo di attacco 95°

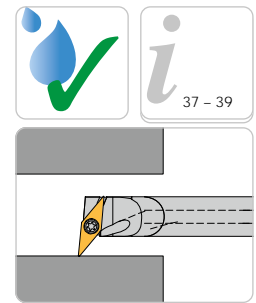
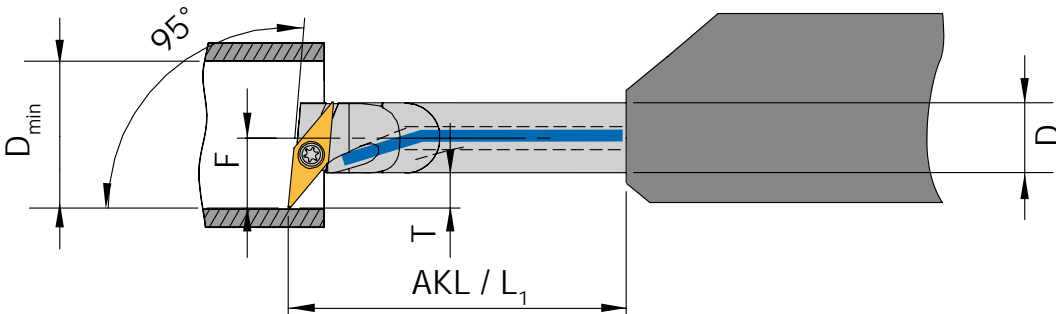

Rechte Ausführung abgebildet
 Right-hand execution shown
 Versione destra in figura

Trägerwerkzeuge / Holders / Utensili

AMS-Bohrstangen - mit innerer Kühlmittelzufuhr / AMS boring bar - with through tool coolant / Bareno AMS - con adduzione interna del refrigerante

Bezeichnung Designation Articolo	D _{min}	AKL	T	F	L ₁	D	Schneideinsatz Insert Inserito
E0406-SVLC/L/R05-AMS	9,2	29	3	6	29	6	VC.. 0501...
E0408-SVLC/R05-AMS	9,2	26	3	5	29	8	VC.. 0501...
E0408-SVLC/L05-AMS	9,2	26	3	5	29	8	VC.. 0501...

Ersatzteile / Spare Parts / Ricambi

Trägerwerkzeug Holder Utensile	Schraube Screw Vite	Schlüssel Key Chiave
E04...-SVLC/L/R05-AMS	AS 0113	KS 2505

Holders with screw clamping
 Steli con fissaggio a vite

SVVC L/R

Anstellwinkel 72,5° / Approach angle 72,5° / Angolo di attacco 72,5°

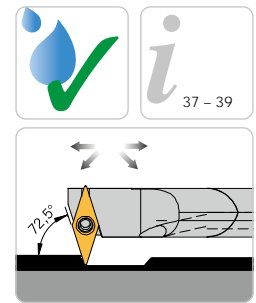

Rechte Ausführung abgebildet
 Right-hand execution shown
 Versione destra in figura

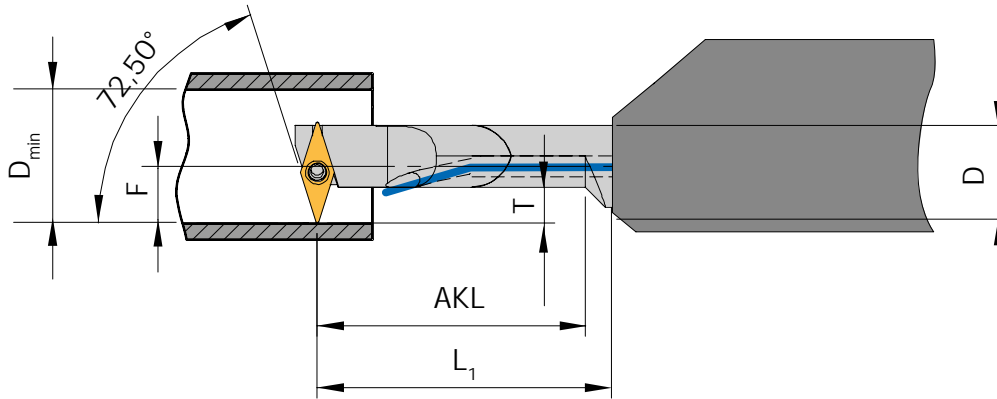

Trägerwerkzeuge / Holders / Utensili

AMS-Bohrstangen - mit innerer Kühlmittelzufuhr / AMS boring bar - with through tool coolant / Bareno AMS - con adduzione interna del refrigerante

Bezeichnung Designation Articolo	D _{min}	AKL	T	F	L ₁	D	Schneideinsatz Insert Inserito
E0406-SVVCL/R05-AMS N	10,3	26	4,5	7	28	6	VC.. 0501...
E0408-SVVCL/R05-AMS N	10,5	26	3,5	6	29	8	VC.. 0501...

Ersatzteile / Spare Parts / Ricambi

Trägerwerkzeug Holder Utensile	Schraube Screw Vite	Schlüssel Key Chiave
E04.-SVVCL/R05-AMS	AS 0112	KS 2505

Holders with screw clamping
 Steli con fissaggio a vite

SVXC L/R

Anstellwinkel 113° / Approach angle 113° / Angolo di attacco 113°

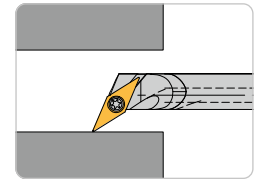

Rechte Ausführung abgebildet
 Right-hand execution shown
 Versione destra in figura

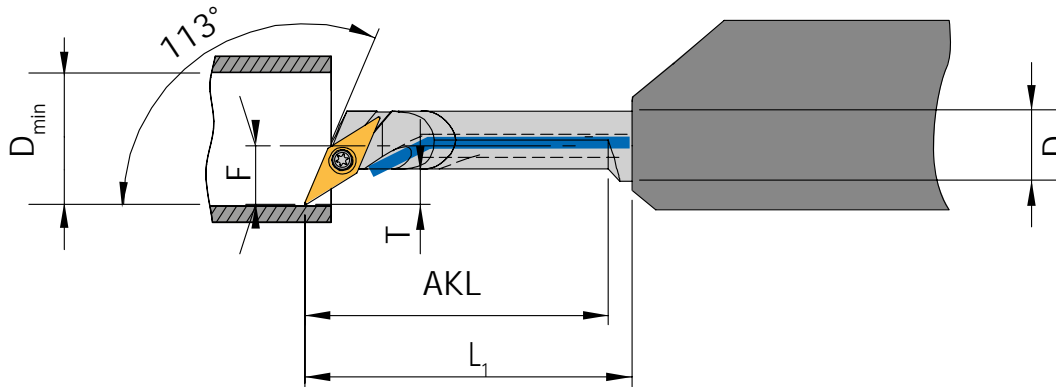

Trägerwerkzeuge / Holders / Utensili

AMS-Bohrstangen - mit innerer Kühlmittelzufuhr / AMS boring bar - with through tool coolant / Bareno AMS - con adduzione interna del refrigerante

Bezeichnung Designation Articolo	D _{min}	AKL	T	F	L ₁	D	Schneideinsatz Insert Inserto
E0406-SVXCL/R05-AMS	8,2	26	3	5	28	6	VC.. 0501...
E0408-SVXCL/R05-AMS	9,2	26	3	5	29	8	VC.. 0501...

Ersatzteile / Spare Parts / Ricambi

Trägerwerkzeug Holder Utensile	Schraube Screw Vite	Schlüssel Key Chiave
E04..-SVXCL/R05-AMS	AS 0113	KS 2505

Holders with screw clamping
 Steli con fissaggio a vite

SWUC L/R

Anstellwinkel 93° / Approach angle 93° / Angolo di attacco 93°

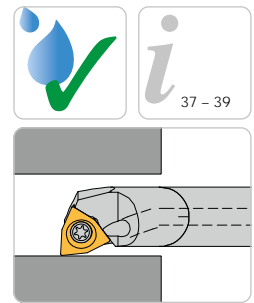
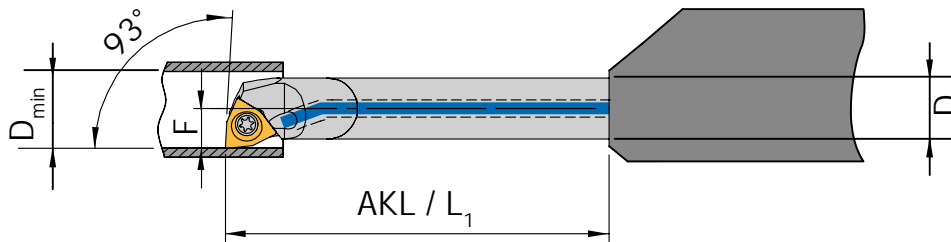

Rechte Ausführung abgebildet
 Right-hand execution shown
 Versione destra in figura

Trägerwerkzeuge / Holders / Utensili

AMS-Bohrstangen - mit innerer Kühlmittelzufuhr / AMS boring bar - with through tool coolant / Bareno AMS - con adduzione interna del refrigerante

Bezeichnung Designation Articolo	D _{min}	AKL	F	L ₁	D	Schneideinsatz Insert Inserto
E06-SWUCR02-AMS	7,8	37,5	3,9	37,5	6	WC.. 0201...
E06-SWUCR02-AMS	7,8	37,5	3,9	37,5	6	WC.. 0201...

Ersatzteile / Spare Parts / Ricambi

Trägerwerkzeug Holder Utensile	Schraube Screw Vite	Schlüssel Key Chiave
E06..-SWUCR02-AMS	T2.03	KS 1886

Special holder
Adattatore speciale

Hydro-Dehn Klemmhalter für Index/Traub - Drehmaschinen / Hydraulic Holder for Index/traub - Holders for lathes / Adattatore idraulici per Index/Traub - Adattatori per torni

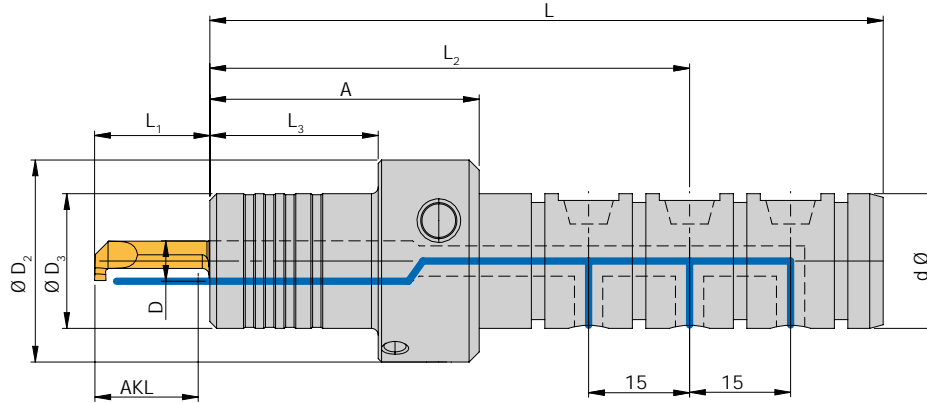

Rechte Ausführung abgebildet
Right-hand execution shown
Versione destra in figura
AKL = Auskraglänge [mm]
AKL = Maximum work length [mm]
AKL = Utile di lavoro [mm]
d = Schaftdurchmesser [mm]
d = Shank diameter [mm]
d = Diametro accoppiamento [mm]

Trägerwerkzeuge / Holders / Utensili

Bezeichnung Designation Articolo	D	D ₂	D ₃	d	L	L ₂	L ₃
HAMS 2004-HYD-TNL-TR	4	30	20	20	92,5	63,8	17,5
HAMS 2006-HYD-TNL-TR	6	30	20	20	100,0	71,3	25
HAMS 2008-HYD-TNL-TR	8	30	20	20	100,0	71,3	25



Auf diese Halter passen alle Schneideinsätze aus dem Drehen-katalog – Kapitel 6 AMS
The inserts for these holders you will find on the turning catalog - Chapter 6 AMS!
Inserti per questi adattatori a catalogo di tornitura - Capitolo 6 AMS!

Auskraglänge /

Maximum work length / Utile di lavoro

D	AKL	L ₁
4	2,0	4,0
4	5,0	6,5
4	6,0	8,0
4	7,5	10,0
4	10,0	12,0
4	15,0	17,0
4	20,0	22,0
6	10,0	12,0
6	18,0	20,0
6	20,0	22,0
6	30,0	32,0
6	40,0	42,0
6	50,0	52,0
8	10,0	12,0
8	25,0	17,0
8	30,0	32,0
8	42,0	44,0
8	45,0	47,0
8	50,0	52,0

Einbaulage, Beispiel
Assembly options, example
Montaggio, esempio

Beispielaufnahme W7040111
Example basic holder W7040111
Esempio W7040111

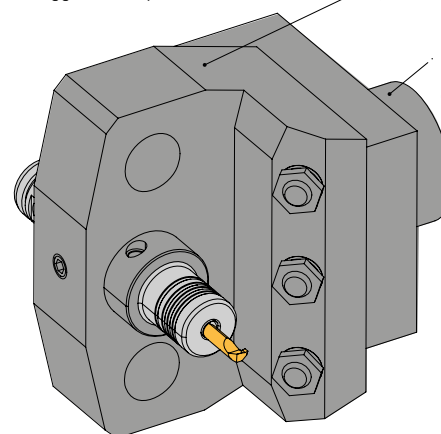

Ersatzteile / Spare Parts / Ricambi

Trägerwerkzeug Holder Utensile	Schraube Screw Vite	O-Ring O-ring O-ring
HAMS...-HYD-TNL-TR	AS 0074 / AS 0043	OR 17X1,5-NBR70

Special holder
Adattatore speciale

Klemmhalter für Index/Traub - Drehmaschinen / Holder for Index/traub - Holders for lathes / Adattatore per Index/Traub - Adattatori per torni

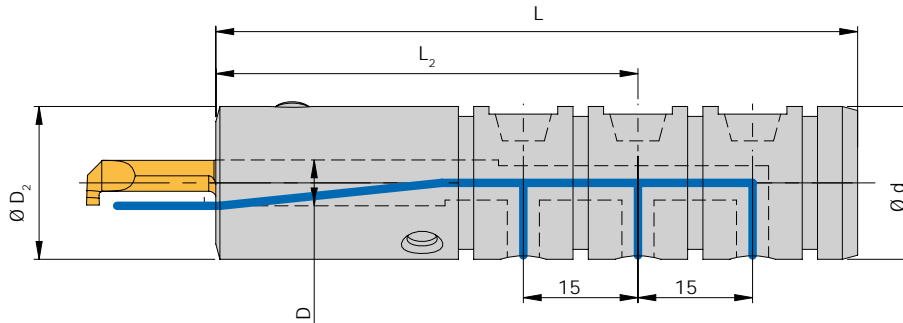

Rechte Ausführung abgebildet
Right-hand execution shown
Versione destra in figura
AKL = Auskraglänge [mm]
AKL = Maximum work length [mm]
AKL = Utile di lavoro [mm]
d = Schaftdurchmesser [mm]
d = Shank diameter [mm]
d = Diametro accoppiamento [mm]

Trägerwerkzeuge / Holders / Utensili

Bezeichnung Designation Articolo	D	D ₂	d	L	L ₂
HAMS 2004-TNL-TR	4	20	20	84	55,3
HAMS 2006-TNL-TR	6	20	20	84	55,3
HAMS 2008-TNL-TR	8	20	20	84	55,3

Auf diese Halter passen alle Schneideinsätze aus dem Drehen-katalog – Kapitel 6 AMS
The inserts for these holders you will find on the turning catalog - Chapter 6 AMS!
Inserti per questi adattatori a catalogo di tornitura - Capitolo 6 AMS!

Auskraglänge /
Maximum work length / Utile di lavoro

D	AKL	L ₁
4	2,0	4,0
4	5,0	6,5
4	6,0	8,0
4	7,5	10,0
4	10,0	12,0
4	15,0	17,0
4	20,0	22,0
6	10,0	12,0
6	18,0	20,0
6	20,0	22,0
6	30,0	32,0
6	40,0	42,0
6	50,0	52,0
8	10,0	12,0
8	25,0	17,0
8	30,0	32,0
8	42,0	44,0
8	45,0	47,0
8	50,0	52,0

Einbau-lage, Beispiel
Assembly options, example
Montaggio, esempio

Beispielaufnahme W7040111
Example basic holder W7040111
Esempio W7040111

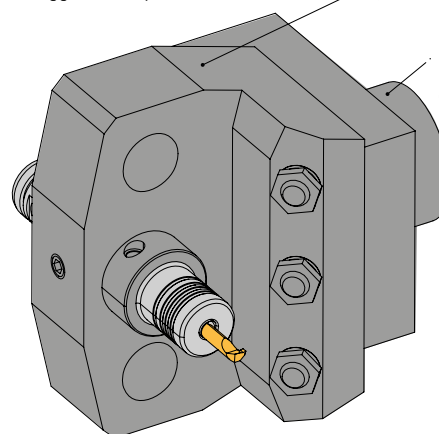

Kompaktschaft 45
Compact shank 45
Gambo compatto 45

Ersatzteile / Spare Parts / Ricambi

Trägerwerkzeug Holder Utensile	Schraube Screw Vite	Schlüssel Key Chiave
HAMS...-TNL-TR	AS 0044	KP 1111

Special holder
Adattatore speciale

Klemmhalter für STAR-Drehmaschinen / Holder for STAR-lathes / Adattatore per STAR-torni



Rechte Ausführung abgebildet
Right-hand execution shown
Versione destra in figura

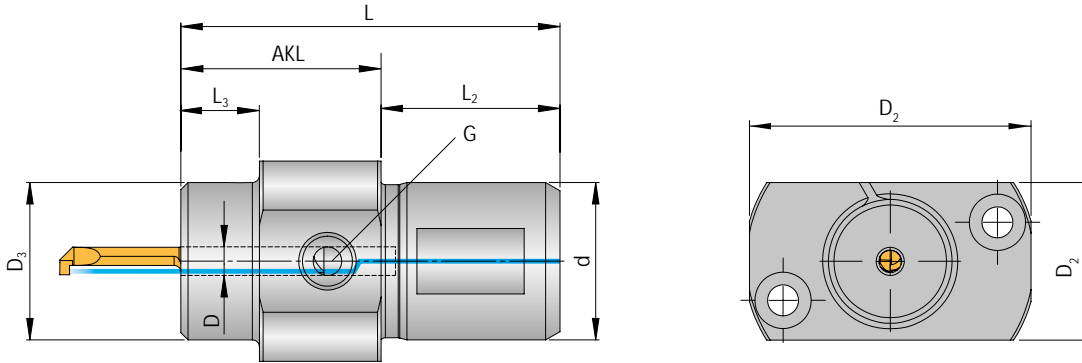

Trägerwerkzeuge / Holders / Utensili

Bezeichnung Designation Articolo	AKL	D	D ₂	D ₃	d	L	L ₂	L ₃	G	Schneideinsatz Insert Inserto
HAMS 2204-A50A-S2-SR	50	4	32,5 x 37,5	22	22	75	35	33	G 1/8	AMS...40R
HAMS 2206-A50A-S2-SR	50	6	32,5 x 37,5	22	22	75	25	33	G 1/8	AMS...60R



Auf diese Halter passen alle Schneideinsätze aus dem Drehen-katalog – Kapitel 6 AMS
The inserts for these holders you will find on the turning catalog - Chapter 6 AMS!
Inserti per questi adattatori a catalogo di tornitura - Capitolo 6 AMS!

Ersatzteile / Spare Parts / Ricambi

Trägerwerkzeug Holder Utensile	Schraube Screw Vite	Schlüssel Key Chiave
HAMS...-A50A-S2-SR	AS 0044	KP 1111

Special holder
Adattatore speciali

Klemmhalter für TORNOS-, TSUGAMI, HANWHA-Drehmaschinen / Holders for TORNOS-, TSUGAMI, HANWHA-lathes / Adattatori per TORNOS-, TSUGAMI, HANWHA-torni

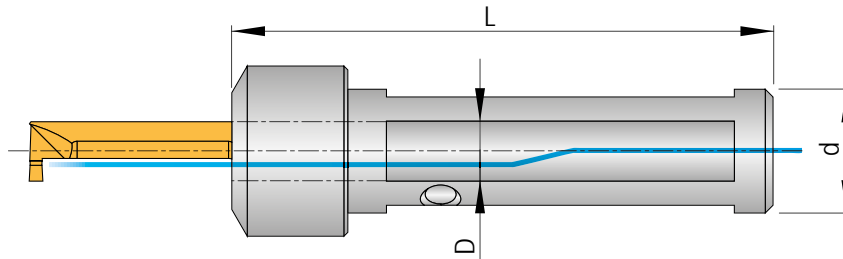

Rechte Ausführung abgebildet
Right-hand execution shown
Versione destra in figura

Trägerwerkzeuge / Holders / Utensili

TORNOS, TSUGAMI, HANWA

Artikel Article Articolo	D	d	L	Anschluss Connection Filetto
HAMS 2504-170-TOR	4	25	170	G 1/8"
HAMS 2506-170-TOR	6	25	170	G 1/8"



Auf diese Halter passen alle Schneideinsätze aus dem Drehen-katalog – Kapitel 6 AMS
The inserts for these holders you will find on the turning catalog - Chapter 6 AMS!
Inserti per questi adattatori a catalogo di tornitura - Capitolo 6 AMS!

Ersatzteile / Spare Parts / Ricambi

Trägerwerkzeug Holder Utensile	Schraube Screw Vite	Schlüssel Key Chiave
HAMS...-TOR	AS 0044	KP 1111

Klemmhalter für STAR-Drehmaschinen / Holder for STAR-lathes / Adattatore per STAR-torni

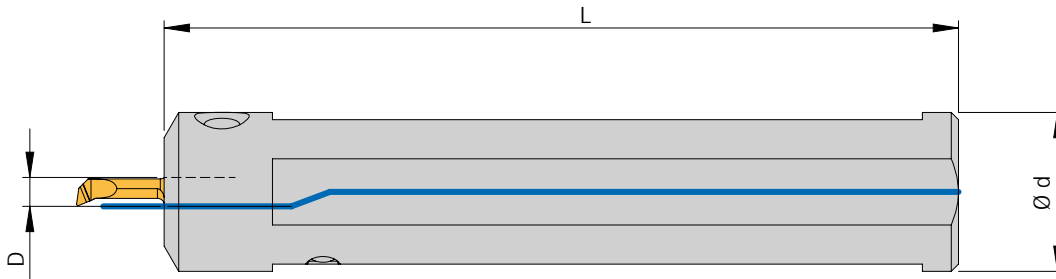

Trägerwerkzeuge / Holders / Utensili

Artikel Article Articolo	D	d	L	Schneideinsatz Insert Inserto
HAMS-US-2204-SR	4	22	110	AMS-US-...40R

Diese Halter können sowohl für die Zustellung in X-Achse sowie für die Zustellung in Y-Achse verwendet werden.

These holders can be used for X-axis and Y-axis feed.

Questi adattatori possono essere utilizzati per l'incremento sull'asse X e sull'asse Y.

Hinweis: Kompletter Halter muss um 90° gedreht werden, um eine andere Zustellachse nutzen zu können! Dabei ist die Spannschraube immer von unten bzw. seitlich zugänglich. Bei Überkopfeinsatz des Halters erfolgt der Zugang zur Spannschraube von oben bzw. seitlich.

Note: The complete holder must be rotated 90° to use another infeed axis! In doing so, the clamping screw can always be accessed from below or from the side. If you use the holder upside down, access can be gained from above or from the side.

Nota: l'adattatore completo deve essere ruotato di 90° per poter utilizzare un altro asse di incremento! La vite di bloccaggio è sempre accessibile dal basso o lateralmente. Se si utilizza l'inserto invertito dell'adattatore, si può accedere alla vite di bloccaggio dall'alto o lateralmente.

Ersatzteile / Spare Parts / Ricambi

Trägerwerkzeug Holder Utensile	Schraube Screw Vite	Schlüssel Key Chiave
HAMS-US-...	AS 0044	KP 1111

Kopieren 32° / Copying 32° / Copiatura 32°

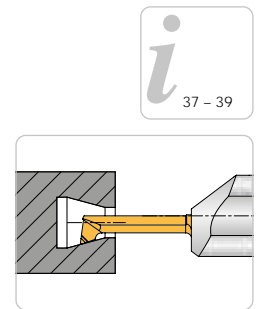
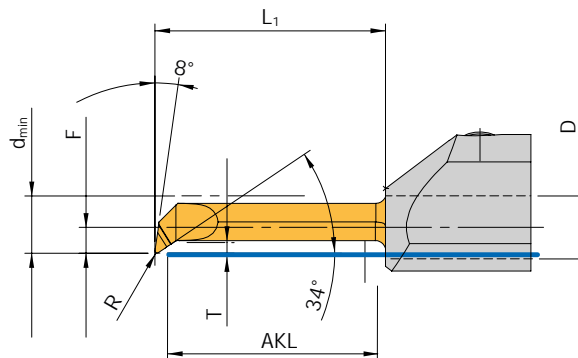

N NEU/NEW/
NUOVO

Bezeichnung Designation Articolo	d _{min}	AKL	T	R	F	L ₁	D	HC
								AP5015
AMS-K32-501002-150.60R	5	15	1,0	0,2	2,45	17	6	N
AMS-K32-501002-200.60R	5	20	1,0	0,2	2,45	22	6	N
AMS-K32-802502-200.80R	8	20	2,5	0,2	3,90	22	8	N

HC = Hartmetall beschichtet / Carbide coated / Metallo duro rivestito

P	●
M	●
K	●
N	●
S	●
H	

● Hauptanwendung
Main application
Applicazione principale

○ Nebenanwendung
Secondary application
Applicazione secondaria

Kopieren / Copying / Copiatura

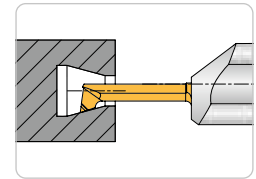
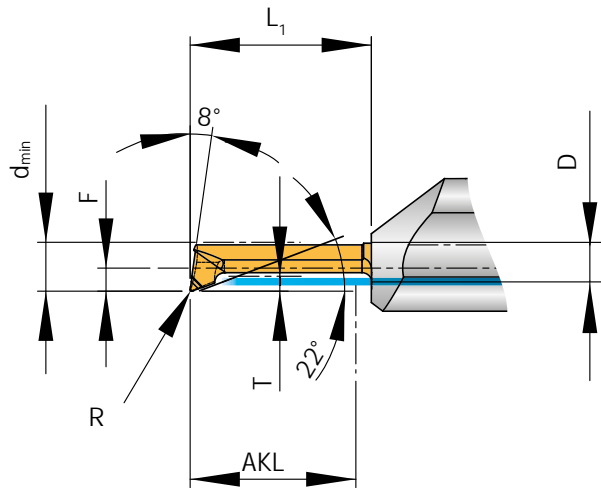

Bezeichnung Designation Articolo	d _{min}	AKL	T	R	F	L ₁	D	HC
								AP5015
AMS-K-2001005-150.40R	2,0	15	0,1	0,05	0,9	17	4	◆
AMS-K-400301-300.40R	4,0	30	0,3	0,10	1,5	32	4	◆
AMS-K-500502-150.60R	5,0	15	0,5	0,20	2,3	17	6	◆
AMS-K-500502-150.60L	5,0	15	0,5	1,20	2,3	17	6	◆
AMS-K-6805005-250.80R	6,8	25	0,5	0,05	3,9	27	8	◆
AMS-K-680502-200.80L	6,8	20	0,5	0,20	3,9	22	8	◆
AMS-K-680502-250.80L	6,8	25	0,5	0,20	3,9	27	8	◆
AMS-K-680502-250.80R	6,8	25	0,5	0,20	3,9	27	8	◆
AMS-K-791002-200.80R	7,9	20	1,0	0,20	3,9	22	8	◆
AMS-K-791002-300.80R	7,9	30	1,0	0,20	3,9	32	8	◆
AMS-K-791002-400.80R	7,9	40	1,0	0,20	3,9	42	8	◆

HC = Hartmetall beschichtet / Carbide coated / Metallo duro rivestito

P	●
M	●
K	●
N	●
S	●
H	

● Hauptanwendung
Main application
Applicazione principale

○ Nebenanwendung
Secondary application
Applicazione secondaria

Kopieren 20/20° | Copying 20/20° | Copiatura 20/20°

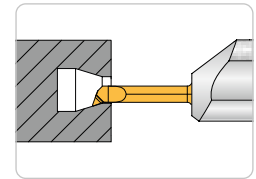
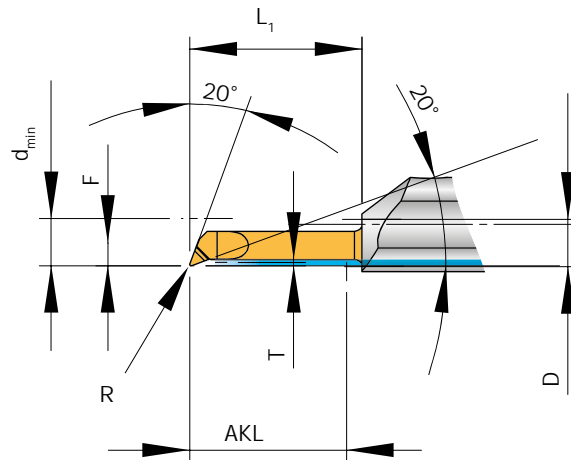

Rechte Ausführung abgebildet
Right-hand execution shown
Versione destra in figura

Bezeichnung Designation Articolo	d _{min}	AKL	T	R	F	L ₁	D	HC
								AP5015
AMS-K2020-5005015-200.60L	6	20	0,5	0,2	2,9	22	6	◆
AMS-K2020-5005015-200.60R	6	20	0,5	0,2	2,9	22	6	◆

HC = Hartmetall beschichtet | Carbide coated | Metallo duro rivestito

P	●
M	●
K	●
N	●
S	●
H	

● Hauptanwendung
Main application
Applicazione principale
○ Nebenanwendung
Secondary application
Applicazione secondaria

Kopieren / Copying / Copiatura

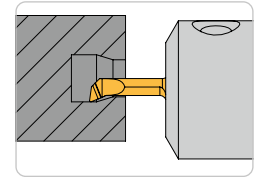
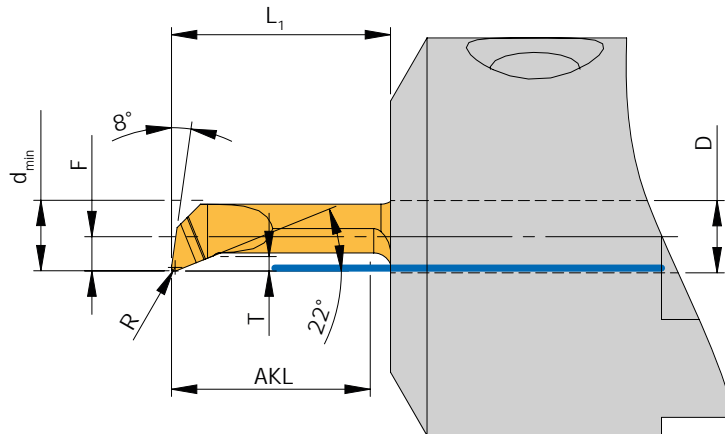

Rechte Ausführung abgebildet
Right-hand execution shown
Versione destra in figura

Bezeichnung Designation Articolo	d _{min}	AKL	T	R	F	L ₁	D	HC
								AP5015
AMS-US-K-390802-100.40R	3,9	10	0,8	0,2	1,9	12	4	◆

HC = Hartmetall beschichtet / Carbide coated / Metallo duro rivestito
Diese Schneideinsätze passen nur auf folgende Halter: HAMS-US-...

P	●
M	●
K	●
N	●
S	●
H	

● Hauptanwendung
Main application
Applicazione principale
○ Nebenanwendung
Secondary application
Applicazione secondaria

Axial Stechen / Axial grooving / Scanalatura assiale

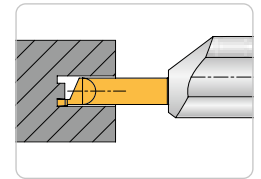
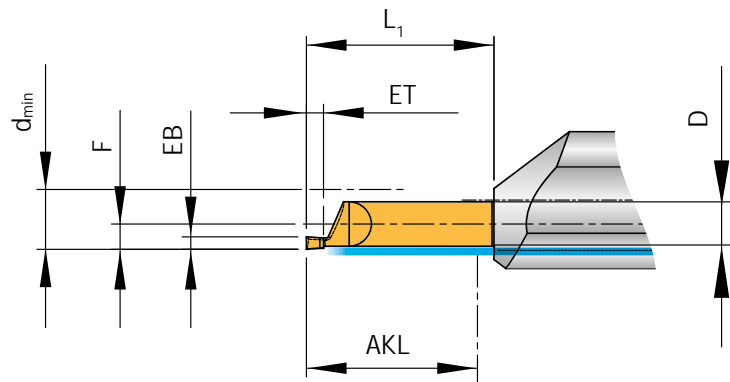

Rechte Ausführung abgebildet
Right-hand execution shown
Versione destra in figura

Bezeichnung Designation Articolo	d _{min}	AKL	EB + 0,03	ET	R	F	L ₁	D	HC
									AP5015
AMS-A-501015005-075.40R	5	7,5	1	1,5	0,05	1,9	9,7	4	◆

HC = Hartmetall beschichtet / Carbide coated / Metallo duro rivestito

P	●
M	●
K	●
N	●
S	●
H	

● Hauptanwendung
Main application
Applicazione principale

○ Nebenanwendung
Secondary application
Applicazione secondaria

Werkstoffgruppe	Gliederung der Werkstoffhauptgruppen und Kennbuchstaben		Brinell-Härte	Zugfestigkeit (N/mm ²)	Zerspanungsgruppe	Schnittgeschwindigkeit Vc (m/min)
						HC
						AP5015
P	Unlegierter Stahl	C 0,25 % gegluht	125	428	P1	20 - 100 - 180
		C >= 0,25 ... >= 0,55 % gegluht	190	639	P2	20 - 100 - 180
		C >= 0,25 ... >= 0,55 % vergütet	210	708	P3	20 - 100 - 180
		C 0,55 % gegluht	190	639	P4	20 - 100 - 180
		C 0,55 % vergütet	300	1013	P5	20 - 100 - 180
		Automatenstahl (kurzspanend) gegluht	220	745	P6	20 - 100 - 180
	Niedrig legierter Stahl	gegluht	175	591	P7	15 - 90 - 160
		vergütet	300	1013	P8	15 - 90 - 160
		vergütet	380	1282	P9	15 - 90 - 160
		vergütet	430	1477	P10	15 - 90 - 160
	Hochlegierter Stahl und hochlegierter Werkzeugstahl	gegluht	200	675	P11	20 - 70 - 120
		gehärtet und angelassen	300	1013	P12	20 - 70 - 120
		gehärtet und angelassen	400	1361	P13	20 - 70 - 120
	Nichtrostender Stahl	ferretisch / martensitisch, gegluht	200	675	P14	20 - 55 - 90
		martensitisch, vergütet	330	1114	P15	20 - 100 - 180
M	Nichtrostender Stahl	austenitisch, abgeschreckt	200	675	M1	20 - 55 - 90
		austenitisch, ausscheidungsgehärtet (PH)	300	1013	M2	15 - 50 - 80
		austenitisch-ferritisch, Duplex	230	778	M3	10 - 35 - 60
K	Temperguss	ferritisch	200	675	K1	20 - 70 - 120
		perlitisch	260	867	K2	20 - 70 - 120
	Grauguss	niedrige Festigkeit	180	602	K3	20 - 80 - 140
		hohe Festigkeit / austenitisch	245	825	K4	20 - 80 - 140
	Gusseisen mit Kugelgraphit	ferritisch	155	518	K5	20 - 75 - 130
		perlitisch	265	885	K6	20 - 75 - 130
	GGV (CGI)		200	675	K7	20 - 70 - 120
N	Aluminium-Knetlegierung	nicht aushärtbar	30	-	N1	20 - 260 - 500
		aushärtbar, ausgehärtet	100	343	N2	20 - 260 - 500
	Aluminium-Gusslegierung	12 % Si, nicht aushärtbar	75	260	N3	20 - 260 - 500
		12 % Si, aushärtbar, ausgehärtet	90	314	N4	20 - 260 - 500
		> 12 % Si, nicht aushärtbar	130	447	N5	20 - 260 - 500
	Magnesiumlegierung	> 12 % Si, nicht aushärtbar	70	250	N6	-
	Kupfer und Kupferlegierung (Bronze / Messing)	unlegiert, Elektrokupfer	100	343	N7	20 - 310 - 600
		Messing, Bronze, Rotguss	90	314	N8	20 - 310 - 600
		Cu-Legierung, kurzspanend	110	382	N9	20 - 310 - 600
		hochfest, Ampco	300	1013	N10	-
	Nichtmetallische Werkstoffe	Thermoplaste (ohne abrasive Füllstoffe)	-	-	N11	-
		Duroplaste (ohne abrasive Füllstoffe)	-	-	N12	-
		Kunststoff glasfaserverstärkt GFRP	-	-	N13	-
		Kunststoff kohlefaserverstärkt CFRP	-	-	N14	-
		Kunststoff aramidfaserverstärkt AFRP	-	-	N15	-
		Graphit (technisch)	80 Shore	-	N16	-
S	Warmfeste Legierungen	Fe-Basis gegluht	200	675	S1	15 - 45 - 75
		Fe-Basis ausgehärtet	280	943	S2	15 - 45 - 75
		Ni- oder Co-Basis gegluht	250	839	S3	15 - 30 - 40
		Ni- oder Co-Basis ausgehärtet	350	1177	S4	15 - 30 - 40
		Ni- oder Co-Basis gegossen	320	1076	S5	15 - 30 - 40
	Titanlegierung	Reintitan	200	675	S6	-
		α- und β-Legierungen, ausgehärtet	375	1262	S7	-
		β-Legierungen	410	1396	S8	-
	Wolframlegierungen		300	1013	S9	-
	Molybdänlegierungen		300	1013	S10	-
H	Gehärteter Stahl	gehärtet und angelassen	50 HRC	-	H1	-
		gehärtet und angelassen	55 HRC	-	H2	-
		gehärtet und angelassen	60 HRC	-	H3	-
	Gehärtetes Gusseisen	gehärtet und angelassen	55 HRC	-	H4	-

Die Tabellenwerte sind Richtwerte.

Es kann notwendig sein, die Werte den jeweiligen Bearbeitungsbedingungen anzupassen.

HC = Hartmetall beschichtet

Material group	Structure of the material groups and identification letters		Brinell hardness HB	Tensile strength Rm (N/mm ²)	Chipping group	Cutting speed Vc (m/min)	
						HC	
							AP5015
P	Unalloyed steel	C 0.25 % annealed	125	428	P1	20 - 100 - 180	
		C >= 0.25 ... >= 0.55 % annealed	190	639	P2	20 - 100 - 180	
		C >= 0.25 ... >= 0.55 % hardened and tempered	210	708	P3	20 - 100 - 180	
		C 0.55 % annealed	190	639	P4	20 - 100 - 180	
		C 0.55 % hardened and tempered	300	1013	P5	20 - 100 - 180	
		Machinig steel (short-chipping) annealed	220	745	P6	20 - 100 - 180	
	Low alloyed steel	annealed	175	591	P7	15 - 90 - 160	
		hardened and tempered	300	1013	P8	15 - 90 - 160	
		hardened and tempered	380	1282	P9	15 - 90 - 160	
		hardened and tempered	430	1477	P10	15 - 90 - 160	
	High alloyed steel and high alloyed tool steel	annealed	200	675	P11	20 - 70 - 120	
		hardened	300	1013	P12	20 - 70 - 120	
		hardened	400	1361	P13	20 - 70 - 120	
	Stainless steel	ferretic / martensitic, annealed	200	675	P14	20 - 55 - 90	
		martensitic, hardened and tempered	330	1114	P15	20 - 100 - 180	
M	Stainless steel	austenitic, chilled	200	675	M1	20 - 55 - 90	
		austenitic, precipitation-hardened (PH)	300	1013	M2	15 - 50 - 80	
		austenitic-ferritic, Duplex	230	778	M3	10 - 35 - 60	
K	Malleable cast iron	ferritic	200	675	K1	20 - 70 - 120	
		pearlitic	260	867	K2	20 - 70 - 120	
K	Cast iron	low tensile strength	180	602	K3	20 - 80 - 140	
		high tensile strength / austenitic	245	825	K4	20 - 80 - 140	
	Cast iron with nodular graphite	ferritic	155	518	K5	20 - 75 - 130	
		pearlitic	265	885	K6	20 - 75 - 130	
GGV (CGI)		200	675	K7	20 - 70 - 120		
N	Aluminium alloys long chipping	not heat treatable	30	-	N1	20 - 260 - 500	
		heat treatable, heat treated	100	343	N2	20 - 260 - 500	
	Casted aluminium alloys	12 % Si, not heat treatable	75	260	N3	20 - 260 - 500	
		12 % Si, heat treatable, heat treated	90	314	N4	20 - 260 - 500	
		> 12 % Si, not heat treatable	130	447	N5	20 - 260 - 500	
	Magnesium alloys	> 12 % Si, not heat treatable	70	250	N6	-	
		Unalloyed, elektrolyte copper	100	343	N7	20 - 310 - 600	
	Copper and copper alloys (Brass / Bronze)	Brass, Bronze	90	314	N8	20 - 310 - 600	
		Cu-alloys, short-chipping	110	382	N9	20 - 310 - 600	
			300	1013	N10	-	
	Non-ferrous materials	Lead alloys (without abrasive filling material)	-	-	N11	-	
		Duroplastic (without abrasive filling material)	-	-	N12	-	
		Plastic glas fibre reinforced GFRP	-	-	N13	-	
		Plastic carbon fibre reinforced CFRP	-	-	N14	-	
		Plastic aramid fibre reinforced AFRP	-	-	N15	-	
		Graphite (tech.)	80 Shore	-	N16	-	
S	High temperature resistant alloys	Fe-based annealed	200	675	S1	15 - 45 - 75	
		Fe-based heat treated	280	943	S2	15 - 45 - 75	
		Ni- or Co-alloyed annealed	250	839	S3	15 - 30 - 40	
		Ni- or Co-alloyed heat treated	350	1177	S4	15 - 30 - 40	
		Ni- or Co-alloyed casting	320	1076	S5	15 - 30 - 40	
	Titanium alloys	Pure titan	200	675	S6	-	
		- and -alloys, heat treated	375	1262	S7	-	
		-alloys	410	1396	S8	-	
	Wolfram alloys		300	1013	S9	-	
	Molybdän alloys		300	1013	S10	-	
H	Hardened steel	hardened	50 HRC	-	H1	-	
		hardened	55 HRC	-	H2	-	
		hardened	60 HRC	-	H3	-	
	Hardened cast iron	hardened	55 HRC	-	H4	-	

The recommended cutting data are only approximate values.
 It may be necessary to adjust them to each individual machining application.
 HC = Carbide coated

Gruppo materiale	Struttura dei gruppi di materiali e lettere di riferimento		Durezza Brinell	Resistenza Rm (N/mm ²)	Gruppo di lavoro	Velocità di taglio Vc (m/min)
						HC
						AP5015
P	Acciai non legato	C 0,25 % ricotto	125	428	P1	20 - 100 - 180
		C >= 0,25 ... >= 0,55 % ricotto	190	639	P2	20 - 100 - 180
		C >= 0,25 ... >= 0,55 % bonificato	210	708	P3	20 - 100 - 180
		C 0,55 % ricotto	190	639	P4	20 - 100 - 180
		C 0,55 % bonificato	300	1013	P5	20 - 100 - 180
		Acciaio (truciolo corto) ricotto	220	745	P6	20 - 100 - 180
	Acciai debolmente legati	ricotto	175	591	P7	15 - 90 - 160
		bonificato	300	1013	P8	15 - 90 - 160
		bonificato	380	1282	P9	15 - 90 - 160
		bonificato	430	1477	P10	15 - 90 - 160
	Acciai fortemente legati e acciai da utensili	ricotto	200	675	P11	20 - 70 - 120
		temprato e rinvenuto	300	1013	P12	20 - 70 - 120
		temprato e rinvenuto	400	1361	P13	20 - 70 - 120
	Acciai inossidabili	ferritico / martensitico, ricotto	200	675	P14	20 - 55 - 90
		martensitico, bonificato	330	1114	P15	20 - 100 - 180
Acciai inossidabili		austenitico, trattato o temperato	200	675	M1	20 - 55 - 90
	austenitico, indurimento per precipitazione (PH)	300	1013	M2	15 - 50 - 80	
	austenitico-ferritico, Duplex	230	778	M3	10 - 35 - 60	
K	Ghisa temprata	ferritico	200	675	K1	20 - 70 - 120
		perlitica	260	867	K2	20 - 70 - 120
	Ghisa grigia	bassa resistenza	180	602	K3	20 - 80 - 140
		alta resistenza / austenitico	245	825	K4	20 - 80 - 140
	Ghisa sferoidale	ferritico	155	518	K5	20 - 75 - 130
GGV (CGI)	perlitica	265	885	K6	20 - 75 - 130	
N	Leghe di Alluminio stampato	non invecchiato	30	-	N1	20 - 260 - 500
		rinvenuto, invecchiato	100	343	N2	20 - 260 - 500
	Leghe di Alluminio da fusione	12 % Si, non invecchiato	75	260	N3	20 - 260 - 500
		12 % Si, rinvenuto, invecchiato	90	314	N4	20 - 260 - 500
		> 12 % Si, non invecchiato	130	447	N5	20 - 260 - 500
	Leghe di magnesio	> 12 % Si, non invecchiato	70	250	N6	-
	Rame e Leghe di Rame (Bronzo / Ottone)	Non Legati, Rame Elettrolitico	100	343	N7	20 - 310 - 600
		Ottone, Bronzo	90	314	N8	20 - 310 - 600
		Leghe Cu, truciolo corto	110	382	N9	20 - 310 - 600
			300	1013	N10	-
	Materiali non metallici	Leghe al piombo (senza materiale di riempimento abrasivo)	-	-	N11	-
		Duroplastico (senza materiale di riempimento abrasivo)	-	-	N12	-
		Plastica rinforzata in fibra di vetro CFRP	-	-	N13	-
		Plastica rinforzata in fibra di carbonio CFRP	-	-	N14	-
		Plastica rinforzata in fibra aramidica AFRP	-	-	N15	-
		Grafite (tecnico)	80 Shore	-	N16	-
S	Leghe resistenti al calore	Base-Fe ricotto	200	675	S1	15 - 45 - 75
		Base-Fe invecchiato	280	943	S2	15 - 45 - 75
		Base Ni o Co ricotto	250	839	S3	15 - 30 - 40
		Base Ni o Co invecchiato	350	1177	S4	15 - 30 - 40
		Base Ni o Co da fusione	320	1076	S5	15 - 30 - 40
	Leghe di Titanio	Titanio puro	200	675	S6	-
		Leghe e , invecchiato	375	1262	S7	-
		Leghe	410	1396	S8	-
	Leghe di tungsteno		300	1013	S9	-
	Leghe di molibdeno		300	1013	S10	-
H	Acciaio Temprato	temprato e rinvenuto	50 HRC	-	H1	-
		temprato e rinvenuto	55 HRC	-	H2	-
		temprato e rinvenuto	60 HRC	-	H3	-
	Ghisa Temprata	temprato e rinvenuto	55 HRC	-	H4	-

I dati indicati in tabella sono valori approssimati.

Può essere necessario adattarli alle singole applicazioni di lavorazione.

HC = Metallo duro rivestito

LANG DREHEN, SCHNELL WECHSELN.

AFC-Trägerwerkzeug: die Revolution für den schnellen Werkzeugwechsel – angemeldet zum Patent.

Ihre Lösung für einen komfortablen Werkzeugwechsel trotz engem Innenraum bei Langdrehmaschinen: Der zweiteilige AFC-Träger, mit dem selbst ungelertes Personal Werkzeuge schnell und sicher austauschen kann.

So funktioniert 's: Der hintere Teil des Trägerwerkzeugs (AHA-Anschlag) wird einmal fixiert. Für den Austausch des Werkzeugs muss nur das Vorderteil abgenommen werden. Ein erneutes Anfahren und Einstellen des Nullpunkts entfällt durch die immer gleiche Länge zur Spitze des Schneideinsatzes damit komplett – egal, ob er das Drehsystem oder das Stechsystem benutzt. Verbunden werden beide Trägerteile einfach über ein Stecksystem mit O-Ring. Dadurch ist das Vorderteil beim Aufsetzen auf die Steckverbindung sofort gesichert – nichts fällt versehentlich in die Maschine. Gleichzeitig bleibt durch eine schwimmend gelagerte Halterung genug Spielraum für einen Ausgleich des Winkelversatzes, die beiden Teile schmiegen sich optimal aneinander. So profitieren Sie von einer hohen Wechselgenauigkeit und einem dichten Kühlmittelkanal.



SCHNELLE VORTEILE des zweiteiligen AFC-Trägerwerkzeugs

Einfach – nur der vordere Teil des Trägers wird zum Werkzeugwechsel abgenommen

Präzise – durch die schwimmend gelagerte Halterung wird der Winkelversatz ausgeglichen

Schnell – Anfahren und Einstellen des Nullpunkts entfallen; so ist das Werkzeug ruckzuck getauscht

Flexibel kombinierbar

- Passend für alle Linearschlitten in entsprechenden Größen

Einfacher Wechsel

- Nur das vordere Trägerteil muss abgenommen werden
- Selbst für ungelertes Personal einfach und sicher in der Anwendung



ARNO DIGITAL // Alle Infos zum AFC-System finden Sie auch unter: langdrehen.arno.de

Schwimmend gelagerte Halterung

- Ausgleich des Winkelversatzes beim Klemmen
- Sicherer Halt beim Aufeinanderstecken – nichts fällt in die Maschine

2-teiliges Trägerwerkzeug

- Hinterer Teil (AHA-Anschlag) zur Fixierung des Nullpunkts
- Vorderer Teil in 70 mm Standardlänge zum schnellen, bequemen Wechsel des Werkzeugs
- Mit und ohne Innenkühlung erhältlich

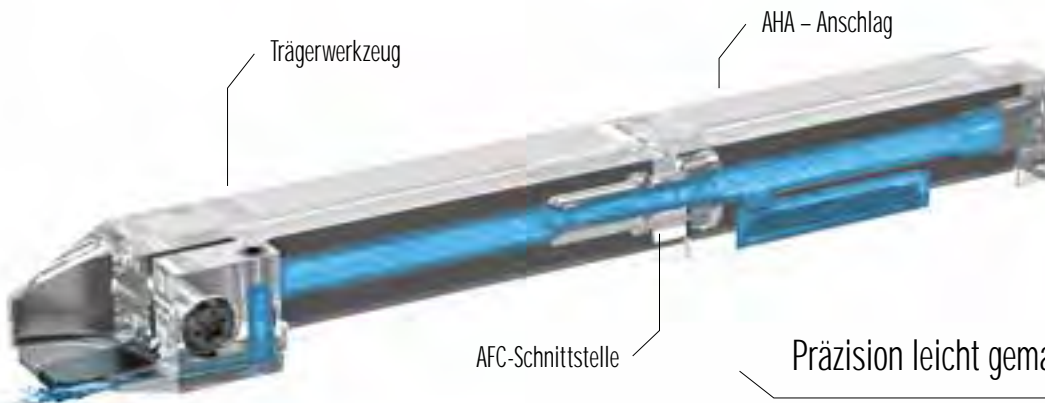

Präzision leicht gemacht

- Wechselgenauigkeit durch Ausgleich des Winkelversatzes
- Ausgezeichnetes Spanverhalten in Verbindung mit dem AFC-Linearschlitten

SWISS TYPE MACHINING, FAST CHANGES.

AFC tool holders: the revolution in fast tool changes – patent applied.

Your solution for easy tool changes despite space constraints in Swiss type machines:
the two-part AFC holder – even untrained staff can replace tools fast and reliably.

This is how it works: The rear part of the tool holder (AHA fixed stop) is first fixed in place. Only the front part is removed to replace the tool. This eliminates the need to restart and recalibrate the zero point since the length to the insert tip is always the same – whether the grooving system or the turning system is used. The two holder parts are simply joined by a connector system with O-ring. The front part is then secured immediately it is placed in the connector – nothing drops into the machine accidentally. At the same time, the floating mount provides enough clearance to compensate for angle offset. The two parts then fit together perfectly. Now you benefit from a high level of precisions when changing tools and a leak-proof coolant hole.



IMMEDIATE BENEFITS of the two-part AFC tool holder

Simple – only the front part of the holder is removed to change the tool

Precise – the floating mount compensate for angle offset

Fast – starting and calibrating the zero point are eliminated, so the tool is changed in no time

Flexibly combinable

- The right sizes to fit all sliding heads

Simple tool changes

- Only the front part of the holder need be removed
- Even untrained staff can change tools easily and reliably in the application



ARNO DIGITAL // For all details on the AFC system, go to langdrehen.arno.de

Floating mount

- Angle offset compensation when clamped
- Secure hold when fitted together – nothing drops into the machine

2-part tool holder

- Rear part (AHA fixed stop) to fix the zero point
- Front part for fast, convenient tool change
- Available with or without internal cooling

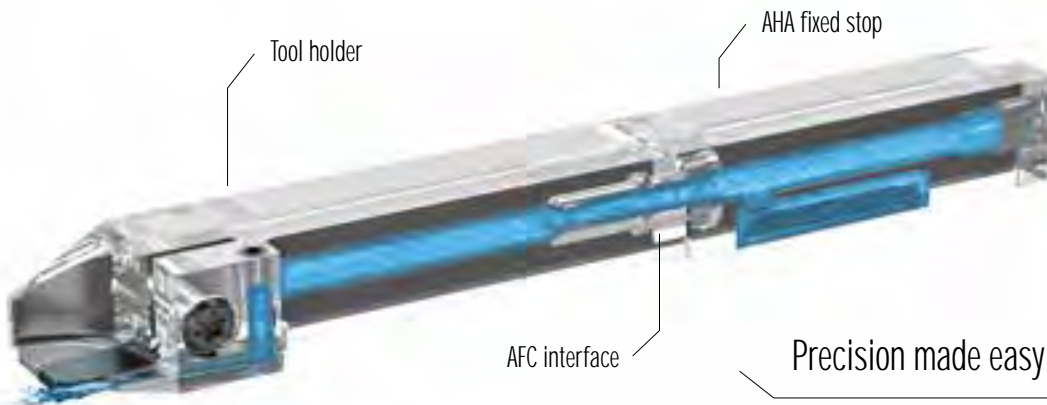

Precision made easy

- Precise tool change by angle offset compensation
- Excellent clamping in connection with the AFC sliding head

TORNITURA CILINDRICA, CAMBIO UTENSILE RAPIDO.

Portautensili AFC: la rivoluzione per il cambio utensile rapido - in attesa di brevetto.

La vostra soluzione per un cambio utensili confortevole nonostante il ridotto spazio interno nei torni a fantina mobile: Il supporto AFC in due parti con il quale anche il personale non addestrato può sostituire gli utensili in modo rapido e sicuro.

Funziona così: la parte posteriore dell'utensile (arresto AHA) viene fissata. Per sostituire l'utensile, deve essere rimossa solo la parte anteriore. Non è necessario un nuovo avviamento e una nuova regolazione del punto zero dal momento che la punta dell'insero ha sempre la medesima lunghezza, indipendentemente dal fatto che si utilizzi un sistema di tornitura o un sistema di scanalatura. Le due parti del supporto vengono collegate mediante un sistema ad innesto con o-ring. La parte anteriore viene subito assicurata quando viene posizionata sull'innesto a spina - nulla può cadere inavvertitamente all'interno della macchina. Allo stesso tempo, un supporto flottante lascia gioco sufficiente per compensare il disallineamento angolare, le due parti si incastrano in modo ottimale l'una nell'altra. Approfittate anche voi di un'elevata precisione di cambio e di un canale ermetico del refrigerante.



VANTAGGI RAPIDI

dell'utensile di supporto AFC in due parti

Semplice - viene rimossa, per il cambio utensile, solo la parte anteriore del supporto

Preciso - grazie al supporto flottante viene compensato lo spostamento angolare

Rapido - non è più necessario raggiungere e regolare il punto zero e l'utensile viene cambiato in pochissimo tempo

Combinabile in maniera flessibile

- Adatto a tutti i pattini lineari nella misura corrispondente

Cambio semplice

- Deve essere asportata solo la parte anteriore del supporto
- Di facile e sicuro utilizzo anche per personale non addestrato



ARNO DIGITAL // Tutte le informazioni relative al sistema AFC sono disponibili anche all'indirizzo: langdrehen.arno.de

Supporti flottanti

- Compensazione dello spostamento angolare durante il bloccaggio
- Tenuta sicura grazie all'inserimento delle parti una nell'altra - nulla può cadere all'interno della macchina

Utensile in 2 parti

- Parte posteriore (Finecorsa AHA) per determinare il punto zero
- Parte anteriore per il cambio rapido e comodo dell'utensile
- Disponibili con e senza raffreddamento interno

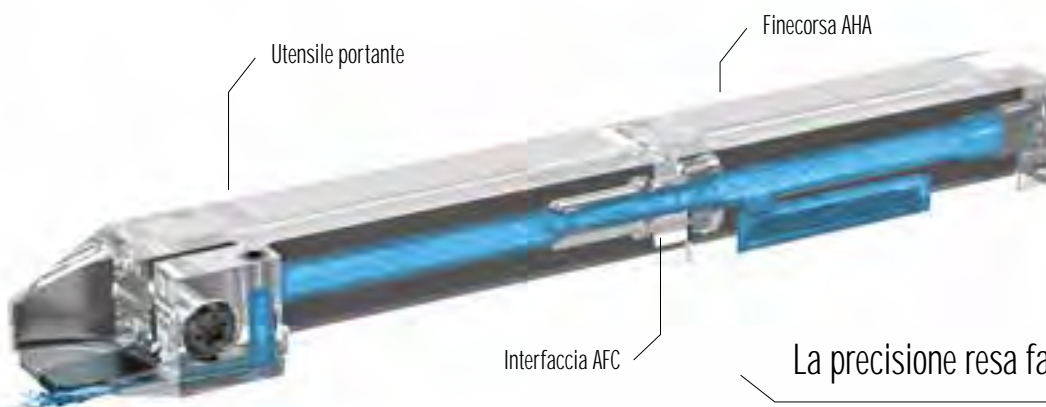

La precisione resa facile

- Precisione del cambio grazie alla compensazione dello spostamento angolare
- Un eccellente comportamento al serraggio in collegamento con il pattino lineare AFC

Vielseitig bei präzisen Einstichen: das neue ATS-System von ARNO.

Versatile for precise parting off: the new ATS System from ARNO.

Versatile nella realizzazione di scanalature precise: il nuovo sistema ATS di ARNO.

Wirtschaftlich dank dreischneidiger Schneidplatten, schnell beim Werkzeugwechsel und stabil durch die Torx-Plus Schraubenklemmung mit optimalem Form- und Kraftschluss: Das ATS Werkzeugsystem zum Außenstechen hat viele Stärken. Vielseitigkeit gehört ebenfalls dazu: Durch die versenkte Klemmschraube und die kompakte Bauform können Sie das ATS-System auch beim Schulterstechen oder im Langdrehbereich einsetzen. Für eine reibungslose Spanabfuhr und hohe Standzeiten sorgt die optimierte Kühlmittelzufuhr der Halter auf die Span- und Freifläche.

Efficient thanks to 3-edged inserts; fast tool changes and rigid due to the Torx-Plus screw clamping system to offer optimised clamping and insert location: The ATS tool system for external parting off has many strengths. One of them is versatility: the countersunk clamping screw and the compact design make the ATS system ideal for applications like shoulder grooving or Swiss type machining. The optimised coolant supply to the cutting edge and tool flank ensure smooth chip evacuation and long tool life.

Economico grazie agli inserti a tre taglienti, veloce al cambio utensile e stabile grazie al bloccaggio a vite Torx-Plus con bloccaggio con accoppiamento dinamico e geometrico ottimale: Il sistema per utensili ATS per l'incisione esterna ha molti punti di forza. Uno di questi è la versatilità: Grazie alla vite di serraggio a testa svasata e alla struttura compatta, è possibile utilizzare il sistema ATS anche per scanalatura di spallamenti o nella tornitura cilindrica. L'adduzione del refrigerante ottimizzata, integrata nel supporto sulla superficie di spoglia superiore e sul fianco garantisce una evacuazione dei trucioli regolare e una lunga durata.

Standard: optimale Kühlung der Freifläche
Standard: optimised cooling of the tool flank
Standard: raffreddamento ottimale del fianco

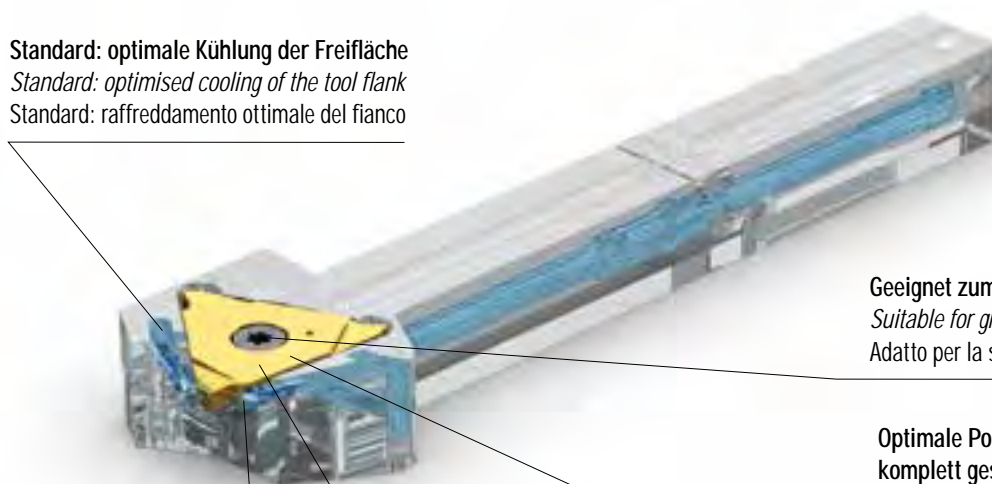

Geeignet zum Stechen an der Schulter
Suitable for grooving at the shoulder
Adatto per la scanalatura degli spallamenti

Optimale Positioniergenauigkeit durch komplett geschliffene Ausführung
Optimal positioning accuracy due to the completely periphery grinding
Precisione di posizionamento ottimale grazie al design completamente rettificato

Standard: direkte Kühlung der Spanfläche
Standard: direct cooling of the cutting edge
Standard: raffreddamento diretto della superficie di spoglia superiore

Stechsystem mit 3-schneidiger T-Wendeschneidplatte
Grooving system with T-shaped indexable insert with 3 cutting edges
Sistema di scanalatura con inserto a 3 taglienti

Einsteckbreite EB ± 0,02 mm
Groove width EB ± 0.02 mm
 Larghezza gola EB ± 0,02 mm

Geometrie -GA mit 8° Spanwinkel
Geometry -GA with 8° rake angle
 Geometria -GA, angolo di spoglia superiore di 8°

Geschliffene Auflagefläche
Ground contact surface
 Superficie di appoggio rettificata



Universelle Hochleistungs-Sorte AP5020
Universal high-performance grade AP5020
 Varietà universale ad alte prestazioni AP5020

Geschliffene Anlageflächen
Ground contact surfaces
 Superfici di contatto al suolo

Einstehtiefe ET max. 6,5 mm
Cutting depths up to ET = 6.5 mm
 Profondità di scanalatura fino a ET = 6,5 mm



Holders with screw clamping
 Steli con fissaggio a vite

HTE-...-IK2-AFC

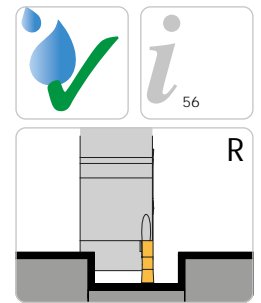
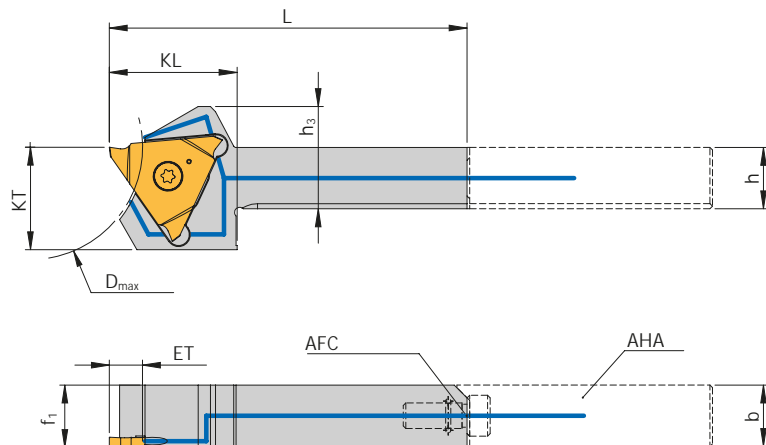

Trägerwerkzeuge / Holders / Utensili

Bezeichnung Designation Articolo	ET _{max}	D _{max}	h	b	h ₃	L	f ₁	KL	KT	Größe Size Gran- dezza	Schneid- einsatz Insert Inserto
HTE-1212L/R-14F-IK2-AFC	6,5	44	12	12	20	70	9,95	25	20	F	T...14F-...
HTE-1212L/R-14H-IK2-AFC N	6,5	44	12	12	20	70	8,95	25	20	H	T...14H-...
HTE-1212L/R-14K-IK2-AFC N	6,5	44	12	12	20	70	7,95	25	20	K	T...14K-...
HTE-1616L/R-14F-IK2-AFC N	6,5	44	16	16	24	70	13,95	25	20	F	T...14F-...
HTE-1616L/R-14H-IK2-AFC N	6,5	44	16	16	24	70	12,95	25	20	H	T...14H-...
HTE-1616L/R-14K-IK2-AFC N	6,5	44	16	16	24	70	11,95	25	20	K	T...14K-...

Ersatzteile / Spare Parts / Ricambi

Trägerwerkzeug Holder Utensile	Schraube Screw Vite	Drehmoment Torque Coppia	Schlüssel Key Chiave	O-Ring O-ring O-ring
HTE-1212L/R-14...-IK2-AFC	AS 0005	2,5 Nm	T5210-IP	OR 4,7X1 FKM80 SCHWARZ
HTE-1616L/R-14...-IK2-AFC	AS 0005	2,5 Nm	T5210-IP	OR 4,7X1,6 NBR70

Geometriebeschreibung / Geometry description / Descrizione delle Geometria

GA

- Hervorragend geeignet für die Bearbeitung von Stahl und nichtrostendem Stahl
- Komplet geschliffene Geometrie
- Hohe Präzision und Wiederholgenauigkeit
- *Excellent for machining steel and stainless steel*
- *Completely ground geometry*
- *High precision and repeatability*
- Adatto in maniera eccellente alla lavorazione di acciaio e acciaio inossidabile
- Geometria completamente rettificata
- Elevata precisione e accuratezza di ripetibilità



Schlichten <i>Finishing</i> Finitura		Mittlere Bearbeitung <i>Medium machining</i> Medie asportazioni			Schruppen <i>Roughing</i> Sgrossatura	
P	M	K	N	S	H	
●	○	○	○	○		

GB

- Sehr weichschneidende Geometrie
- Komplet geschliffene Geometrie
- Geringe Schnittkräfte
- *Very soft cutting geometry*
- *Completely ground geometry*
- *Low cutting force*
- Geometria dal taglio dolce
- Geometria completamente rettificata
- Ridotta forza di taglio



Schlichten <i>Finishing</i> Finitura		Mittlere Bearbeitung <i>Medium machining</i> Medie asportazioni			Schruppen <i>Roughing</i> Sgrossatura	
P	M	K	N	S	H	
●	○	○	○	○		

Sortenbeschreibung / Grade discription / Descrizione delle Geometria

AP5020

- Universell einsetzbare Sorte
- Gutes Zusammenspiel von Verschleißfestigkeit und Zähigkeit
- Hohe Beständigkeit gegen Oxidation
- *Universally applicable type*
- *Good interplay between wear resistance and toughness*
- *High resistance to oxidation*
- Varietà utilizzabile universalmente
- Buona interazione tra resistenza all'usura e tenacità
- Elevata resistenza all'ossidazione

PVD



Verschleißfestigkeit <i>Wear resistance</i> Resistenza all'usura										Zähigkeit <i>Toughness</i> Tenacità																													
10										20						30						40																	
P										M						K						N						S						H					
●										○						○						○						○											

TE14

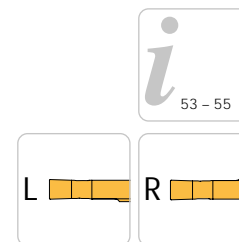
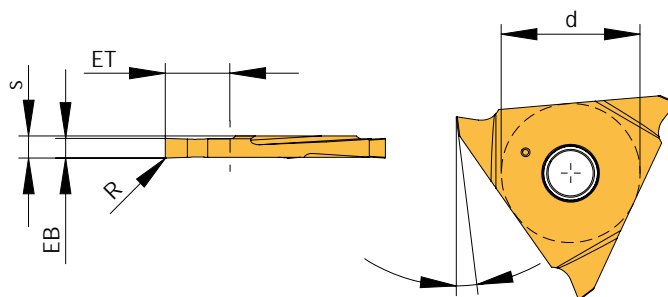

Bezeichnung Designation Articolo	EB ± 0,02	R	ET	d	s	α	Größe Size Grandezza	HC
								AP5020
TE14F-100-3001EL-GA	1,0	0,1	3,0	14	2,25	7°	F	N
TE14F-100-3001ER-GA	1,0	0,1	3,0	14	2,25	7°	F	N
TE14F-100-6501EL-GA	1,0	0,1	6,5	14	2,25	7°	F	N
TE14F-100-6501ER-GA	1,0	0,1	6,5	14	2,25	7°	F	N
TE14F-150-3001EL-GA	1,5	0,1	3,0	14	2,25	7°	F	N
TE14F-150-3001ER-GA	1,5	0,1	3,0	14	2,25	7°	F	N
TE14F-150-6501EL-GA	1,5	0,1	6,5	14	2,25	7°	F	N
TE14F-150-6501ER-GA	1,5	0,1	6,5	14	2,25	7°	F	N
TE14F-200-6501EL-GA	2,0	0,1	6,5	14	2,25	7°	F	◆
TE14F-200-6501ER-GA	2,0	0,1	6,5	14	2,25	7°	F	◆
TE14F-200-6502EL-GA	2,0	0,2	6,5	14	2,25	7°	F	◆
TE14F-200-6502ER-GA	2,0	0,2	6,5	14	2,25	7°	F	◆
TE14H-250-6502EL-GA	2,5	0,2	6,5	14	3,25	7°	H	N
TE14H-250-6502ER-GA	2,5	0,2	6,5	14	3,25	7°	H	N
TE14H-250-6504EL-GA	2,5	0,4	6,5	14	3,25	7°	H	N
TE14H-250-6504ER-GA	2,5	0,4	6,5	14	3,25	7°	H	N
TE14H-300-6502EL-GA	3,0	0,2	6,5	14	3,25	7°	H	N
TE14H-300-6502ER-GA	3,0	0,2	6,5	14	3,25	7°	H	N
TE14H-300-6504EL-GA	3,0	0,4	6,5	14	3,25	7°	H	N
TE14H-300-6504ER-GA	3,0	0,4	6,5	14	3,25	7°	H	N
TE14K-400-6502EL-GA	4,0	0,2	6,5	14	4,25	7°	K	N
TE14K-400-6502ER-GA	4,0	0,2	6,5	14	4,25	7°	K	N
TE14K-400-6504EL-GA	4,0	0,4	6,5	14	4,25	7°	K	N
TE14K-400-6504ER-GA	4,0	0,4	6,5	14	4,25	7°	K	N

HC = Hartmetall beschichtet / Carbide coated / Metallo duro rivestito

P	●
M	○
K	○
N	○
S	○
H	○

● Hauptanwendung
Main application
Applicazione principale
○ Nebenanwendung
Secondary application
Applicazione secondaria

TV14 ...

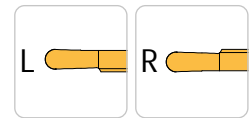
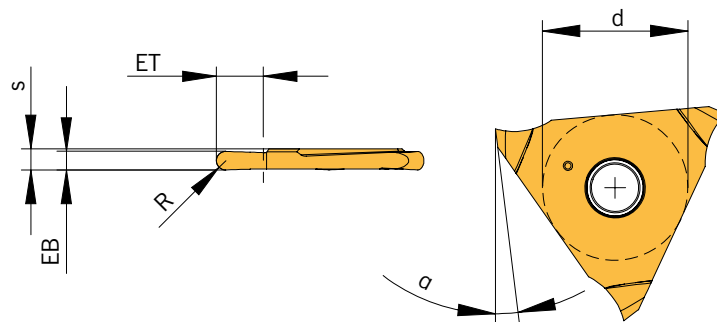

Bezeichnung Designation Articolo	EB ± 0,02	R	ET	d	s	α	Größe Size Grandezza	HC
								AP5020
TV14F-100-3005EL-GB	1	0,5	3	14	2,25	7°	F	N
TV14F-100-3005ER-GB	1	0,5	3	14	2,25	7°	F	N
TV14F-200-5010EL-GB	2	1,0	5	14	2,25	7°	F	N
TV14F-200-5010ER-GB	2	1,0	5	14	2,25	7°	F	N
TV14H-300-5015EL-GB	3	1,5	5	14	3,25	7°	H	N
TV14H-300-5015ER-GB	3	1,5	5	14	3,25	7°	H	N
TV14K-400-5020EL-GB	4	2,0	5	14	4,25	7°	K	N
TV14K-400-5020ER-GB	4	2,0	5	14	4,25	7°	K	N

HC = Hartmetall beschichtet / Carbide coated / Metallo duro rivestito

P	●
M	○
K	○
N	○
S	○
H	

● Hauptanwendung
Main application
Applicazione principale

○ Nebenanwendung
Secondary application
Applicazione secondaria

TS14 ...

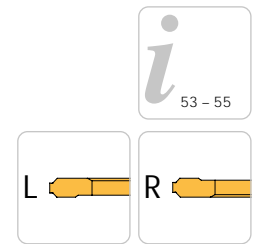
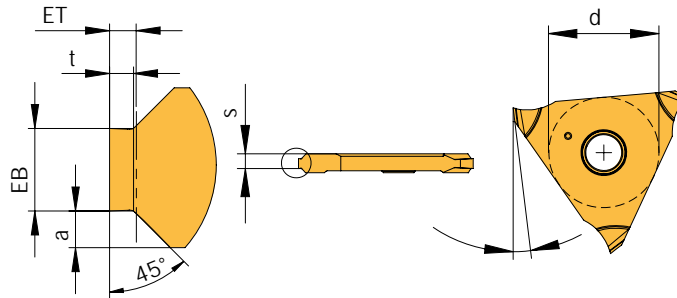

N NEU/NEW/
NUOVO

Bezeichnung Designation Articolo	EB ± 0,05	m*	ET	a	t	d	α	Größe Size Grandezza	HC
									AP5020
TS14F-110-F020EL-GB	1,24	1,10	0,20	0,55	0,19	14	7°	F	N
TS14F-110-F020ER-GB	1,24	1,10	0,20	0,55	0,19	14	7°	F	N
TS14F-110-F025EL-GB	1,24	1,10	0,25	0,55	0,24	14	7°	F	N
TS14F-110-F025ER-GB	1,24	1,10	0,25	0,55	0,24	14	7°	F	N
TS14F-110-F030EL-GB	1,24	1,10	0,30	0,55	0,29	14	7°	F	N
TS14F-110-F030ER-GB	1,24	1,10	0,30	0,55	0,29	14	7°	F	N
TS14F-110-F035EL-GB	1,24	1,10	0,35	0,55	0,33	14	7°	F	N
TS14F-110-F035ER-GB	1,24	1,10	0,35	0,55	0,33	14	7°	F	N
TS14F-110-F040EL-GB	1,24	1,10	0,40	0,55	0,36	14	7°	F	N
TS14F-110-F040ER-GB	1,24	1,10	0,40	0,55	0,36	14	7°	F	N
TS14F-130-F055EL-GB	1,44	1,30	0,55	0,55	0,45	14	7°	F	N
TS14F-130-F055ER-GB	1,44	1,30	0,55	0,55	0,45	14	7°	F	N
TS14H-160-F070EL-GB	1,74	1,60	0,70	0,55	0,60	14	7°	H	N
TS14H-160-F070ER-GB	1,74	1,60	0,70	0,55	0,60	14	7°	H	N
TS14H-160-F085EL-GB	1,74	1,60	0,85	0,55	0,75	14	7°	H	N
TS14H-160-F085ER-GB	1,74	1,60	0,85	0,55	0,75	14	7°	H	N
TS14H-160-F100EL-GB	1,74	1,60	1,00	0,55	0,85	14	7°	H	N
TS14H-160-F100ER-GB	1,74	1,60	1,00	0,55	0,85	14	7°	H	N
TS14H-185-F100EL-GB	1,99	1,85	1,00	0,55	0,85	14	7°	H	N
TS14H-185-F100ER-GB	1,99	1,85	1,00	0,55	0,85	14	7°	H	N
TS14H-185-F125EL-GB	1,99	1,85	1,25	0,55	1,10	14	7°	H	N
TS14H-185-F125ER-GB	1,99	1,85	1,25	0,55	1,10	14	7°	H	N
TS14H-215-F150EL-GB	2,29	2,15	1,50	0,55	1,35	14	7°	H	N
TS14H-215-F150ER-GB	2,29	2,15	1,50	0,55	1,35	14	7°	H	N
TS14K-265-F150EL-GB	2,79	2,65	1,50	0,55	1,35	14	7°	K	N
TS14K-265-F150ER-GB	2,79	2,65	1,50	0,55	1,35	14	7°	K	N
TS14K-265-F175EL-GB	2,79	2,65	1,75	0,55	1,60	14	7°	K	N
TS14K-265-F175ER-GB	2,79	2,65	1,75	0,55	1,60	14	7°	K	N
TS14K-315-F175EL-GB	3,29	3,15	1,75	0,55	1,60	14	7°	K	N
TS14K-315-F175ER-GB	3,29	3,15	1,75	0,55	1,60	14	7°	K	N

HC = Hartmetall beschichtet / Carbide coated / Metallo duro rivestito
*Nutbreite m

P	●
M	○
K	○
N	○
S	○
H	○

● Hauptanwendung / Main application / Applicazione principale

○ Nebenanwendung / Secondary application / Applicazione secondaria

Werkstoffgruppe	Gliederung der Werkstoffhauptgruppen und Kennbuchstaben		Brinell-Härte	Zugfestigkeit (N/mm ²)	Zerspanungsgruppe	Schnittgeschwindigkeit Vc (m/min)
						HC
						AP5020
P	Unlegierter Stahl	C 0,25 % gegluht	125	428	P1	120 - 150 - 180
		C >= 0,25 ... >= 0,55 % gegluht	190	639	P2	80 - 115 - 150
		C >= 0,25 ... >= 0,55 % vergütet	210	708	P3	60 - 100 - 140
		C 0,55 % gegluht	190	639	P4	80 - 115 - 150
		C 0,55 % vergütet	300	1013	P5	60 - 100 - 140
		Automatenstahl (kurzspanend) gegluht	220	745	P6	80 - 115 - 150
	Niedrig legierter Stahl	gegluht	175	591	P7	80 - 125 - 170
		vergütet	300	1013	P8	60 - 95 - 130
		vergütet	380	1282	P9	60 - 95 - 130
		vergütet	430	1477	P10	60 - 90 - 120
		gegluht	200	675	P11	80 - 110 - 140
	Hochlegierter Stahl und hochlegierter Werkzeugstahl	gehärtet und angelassen	300	1013	P12	50 - 85 - 120
		gehärtet und angelassen	400	1361	P13	50 - 85 - 120
	Nichtrostender Stahl	ferretisch / martensitisch, gegluht	200	675	P14	60 - 115 - 170
		martensitisch, vergütet	330	1114	P15	50 - 75 - 100
M	Nichtrostender Stahl	austenitisch, abgeschreckt	200	675	M1	60 - 90 - 120
		austenitisch, ausscheidungsgehärtet (PH)	300	1013	M2	50 - 70 - 90
		austenitisch-ferritisch, Duplex	230	778	M3	50 - 70 - 90
K	Temperguss	ferritisch	200	675	K1	-
		perlitisch	260	867	K2	-
	Grauguss	niedrige Festigkeit	180	602	K3	-
		hohe Festigkeit / austenitisch	245	825	K4	-
	Gusseisen mit Kugelgraphit	ferritisch	155	518	K5	-
		perlitisch	265	885	K6	-
	GGV (CGI)		200	675	K7	-
N	Aluminium-Knetlegierung	nicht aushärtbar	30	-	N1	100 - 300 - 500
		aushärtbar, ausgehärtet	100	343	N2	100 - 200 - 300
		12 % Si, nicht aushärtbar	75	260	N3	100 - 300 - 500
	Aluminium-Gusslegierung	12 % Si, aushärtbar, ausgehärtet	90	314	N4	100 - 200 - 300
		> 12 % Si, nicht aushärtbar	130	447	N5	100 - 150 - 200
	Magnesiumlegierung	> 12 % Si, nicht aushärtbar	70	250	N6	-
	Kupfer und Kupferlegierung (Bronze / Messing)	unlegiert, Elektrokupfer	100	343	N7	100 - 200 - 300
		Messing, Bronze, Rotguss	90	314	N8	100 - 300 - 500
		Cu-Legierung, kurzspanend	110	382	N9	100 - 200 - 300
		hochfest, Ampco	300	1013	N10	-
		Graphit (technisch)	80 Shore	-	N16	-
	Nichtmetallische Werkstoffe	Thermoplaste (ohne abrasive Füllstoffe)	-	-	N11	80 - 130 - 180
		Duroplaste (ohne abrasive Füllstoffe)	-	-	N12	80 - 130 - 180
		Kunststoff glasfaserverstärkt GFRP	-	-	N13	60 - 105 - 150
		Kunststoff kohlefaserverstärkt CFRP	-	-	N14	60 - 105 - 150
		Kunststoff aramidfaserverstärkt AFRP	-	-	N15	60 - 105 - 150
Graphit (technisch)		80 Shore	-	N16	-	
S	Warmfeste Legierungen	Fe-Basis gegluht	200	675	S1	20 - 35 - 50
		Fe-Basis ausgehärtet	280	943	S2	20 - 30 - 40
		Ni- oder Co-Basis gegluht	250	839	S3	15 - 20 - 25
		Ni- oder Co-Basis ausgehärtet	350	1177	S4	10 - 15 - 20
		Ni- oder Co-Basis gegossen	320	1076	S5	10 - 15 - 20
	Titanlegierung	Reintitan	200	675	S6	50 - 85 - 120
		α- und β-Legierungen, ausgehärtet	375	1262	S7	30 - 40 - 50
		β-Legierungen	410	1396	S8	25 - 35 - 45
	Wolframlegierungen		300	1013	S9	-
	Molybdänlegierungen		300	1013	S10	-
H	Gehärteter Stahl	gehärtet und angelassen	50 HRC	-	H1	-
		gehärtet und angelassen	55 HRC	-	H2	-
		gehärtet und angelassen	60 HRC	-	H3	-
	Gehärtetes Gusseisen	gehärtet und angelassen	55 HRC	-	H4	-

Die Tabellenwerte sind Richtwerte.
 Es kann notwendig sein, die Werte den jeweiligen Bearbeitungsbedingungen anzupassen.
 HC = Hartmetall beschichtet

Material group	Structure of the material groups and identification letters		Brinell hardness HB	Tensile strength Rm (N/mm ²)	Chipping group	Cutting speed Vc (m/min)
						HC
						AP5020
P	Unalloyed steel	C 0.25 % annealed	125	428	P1	120 - 150 - 180
		C >= 0.25 ... >= 0.55 % annealed	190	639	P2	80 - 115 - 150
		C >= 0.25 ... >= 0.55 % hardened and tempered	210	708	P3	60 - 100 - 140
		C 0.55 % annealed	190	639	P4	80 - 115 - 150
		C 0.55 % hardened and tempered	300	1013	P5	60 - 100 - 140
		Machinig steel (short-chipping) annealed	220	745	P6	80 - 115 - 150
	Low alloyed steel	annealed	175	591	P7	80 - 125 - 170
		hardened and tempered	300	1013	P8	60 - 95 - 130
		hardened and tempered	380	1282	P9	60 - 95 - 130
		hardened and tempered	430	1477	P10	60 - 90 - 120
	High alloyed steel and high alloyed tool steel	annealed	200	675	P11	80 - 110 - 140
hardened		300	1013	P12	50 - 85 - 120	
hardened		400	1361	P13	50 - 85 - 120	
Stainless steel	ferretic / martensitic, annealed	200	675	P14	60 - 115 - 170	
	martensitic, hardened and tempered	330	1114	P15	50 - 75 - 100	
	austenitic, chilled	200	675	M1	60 - 90 - 120	
M Stainless steel	austenitic, precipitation-hardened (PH)	300	1013	M2	50 - 70 - 90	
	austenitic-ferritic, Duplex	230	778	M3	50 - 70 - 90	
	ferritic	200	675	K1	-	
K	Malleable cast iron	pearlitic	260	867	K2	-
		low tensile strength	180	602	K3	-
	Cast iron	high tensile strength / austenitic	245	825	K4	-
		ferritic	155	518	K5	-
	Cast iron with nodular graphite	pearlitic	265	885	K6	-
		GGV (CGI)	200	675	K7	-
	N	Aluminium alloys long chipping	not heat treatable	30	-	N1
heat treatable, heat treated			100	343	N2	100 - 200 - 300
Casted aluminium alloys		12 % Si, not heat treatable	75	260	N3	100 - 300 - 500
		12 % Si, heat treatable, heat treated	90	314	N4	100 - 200 - 300
		> 12 % Si, not heat treatable	130	447	N5	100 - 150 - 200
Magnesium alloys		> 12 % Si, not heat treatable	70	250	N6	-
		Unalloyed, elektrolyte copper	100	343	N7	100 - 200 - 300
Copper and copper alloys (Brass / Bronze)		Brass, Bronze	90	314	N8	100 - 300 - 500
		Cu-alloys, short-chipping	110	382	N9	100 - 200 - 300
			300	1013	N10	-
Non-ferrous materials		Lead alloys (without abrasive filling material)	-	-	N11	80 - 130 - 180
		Duroplastic (without abrasive filling material)	-	-	N12	80 - 130 - 180
		Plastic glas fibre reinforced GFRP	-	-	N13	60 - 105 - 150
		Plastic carbon fibre reinforced CFRP	-	-	N14	60 - 105 - 150
		Plastic aramid fibre reinforced AFRP	-	-	N15	60 - 105 - 150
		Graphite (tech.)	80 Shore	-	N16	-
S	High temperature resistant alloys	Fe-based annealed	200	675	S1	20 - 35 - 50
		Fe-based heat treated	280	943	S2	20 - 30 - 40
		Ni- or Co-alloyed annealed	250	839	S3	15 - 20 - 25
		Ni- or Co-alloyed heat treated	350	1177	S4	10 - 15 - 20
		Ni- or Co-alloyed casting	320	1076	S5	10 - 15 - 20
	Titanium alloys	Pure titan	200	675	S6	50 - 85 - 120
		- and -alloys, heat treated	375	1262	S7	30 - 40 - 50
		-alloys	410	1396	S8	25 - 35 - 45
	Wolfram alloys		300	1013	S9	-
	Molybdän alloys		300	1013	S10	-
H	Hardened steel	hardened	50 HRC	-	H1	-
		hardened	55 HRC	-	H2	-
		hardened	60 HRC	-	H3	-
	Hardened cast iron	hardened	55 HRC	-	H4	-

The recommended cutting data are only approximate values.
 It may be necessary to adjust them to each individual machining application.
 HC = Carbide coated

Gruppo materiale	Struttura dei gruppi di materiali e lettere di riferimento				Durezza Brinell	Resistenza Rm (N/mm ²)	Gruppo di lavoro	Velocità di taglio Vc (m/min)
								HC
								AP5020
P	Acciai non legato	C 0,25 %	ricotto	125	428	P1	120 - 150 - 180	
		C >= 0,25 ... >= 0,55 %	ricotto	190	639	P2	80 - 115 - 150	
		C >= 0,25 ... >= 0,55 %	bonificato	210	708	P3	60 - 100 - 140	
		C 0,55 %	ricotto	190	639	P4	80 - 115 - 150	
		C 0,55 %	bonificato	300	1013	P5	60 - 100 - 140	
		Acciaio (truciolo corto)	ricotto	220	745	P6	80 - 115 - 150	
	Acciai debolmente legati	ricotto		175	591	P7	80 - 125 - 170	
		bonificato		300	1013	P8	60 - 95 - 130	
		bonificato		380	1282	P9	60 - 95 - 130	
		bonificato		430	1477	P10	60 - 90 - 120	
	Acciai fortemente legati e acciai da utensili	ricotto		200	675	P11	80 - 110 - 140	
temprato e rinvenuto			300	1013	P12	50 - 85 - 120		
temprato e rinvenuto			400	1361	P13	50 - 85 - 120		
Acciai inossidabili	ferritico / martensitico, ricotto		200	675	P14	60 - 115 - 170		
	martensitico, bonificato		330	1114	P15	50 - 75 - 100		
M	Acciai inossidabili	austenitico, trattato o temperato		200	675	M1	60 - 90 - 120	
		austenitico, indurimento per precipitazione (PH)		300	1013	M2	50 - 70 - 90	
		austenitico-ferritico, Duplex		230	778	M3	50 - 70 - 90	
K	Ghisa temprata	ferritico		200	675	K1	-	
		perlitica		260	867	K2	-	
	Ghisa grigia	bassa resistenza		180	602	K3	-	
		alta resistenza / austenitico		245	825	K4	-	
	Ghisa sferoidale	ferritico		155	518	K5	-	
GGV (CGI)	perlitica		265	885	K6	-		
			200	675	K7	-		
N	Leghe di Alluminio stampato	non invecchiato		30	-	N1	100 - 300 - 500	
		rinvenuto, invecchiato		100	343	N2	100 - 200 - 300	
	Leghe di Alluminio da fusione	12 % Si, non invecchiato		75	260	N3	100 - 300 - 500	
		12 % Si, rinvenuto, invecchiato		90	314	N4	100 - 200 - 300	
		> 12 % Si, non invecchiato		130	447	N5	100 - 150 - 200	
	Leghe di magnesio	> 12 % Si, non invecchiato		70	250	N6	-	
	Rame e Leghe di Rame (Bronzo / Ottone)	Non legati, Rame Elettrolitico		100	343	N7	100 - 200 - 300	
		Ottone, Bronzo		90	314	N8	100 - 300 - 500	
		Leghe Cu, truciolo corto		110	382	N9	100 - 200 - 300	
				300	1013	N10	-	
		Materiali non metallici	Leghe al piombo (senza materiale di riempimento abrasivo)		-	-	N11	80 - 130 - 180
			Duroplastico (senza materiale di riempimento abrasivo)		-	-	N12	80 - 130 - 180
	Plastica rinforzata in fibra di vetro CFRP			-	-	N13	60 - 105 - 150	
	Plastica rinforzata in fibra di carbonio CFRP			-	-	N14	60 - 105 - 150	
	Plastica rinforzata in fibra aramidica AFRP			-	-	N15	60 - 105 - 150	
	Grafite (tecnico)			80 Shore	-	N16	-	
S	Leghe resistenti al calore	Base-Fe	ricotto	200	675	S1	20 - 35 - 50	
		Base-Fe	invecchiato	280	943	S2	20 - 30 - 40	
		Base Ni o Co	ricotto	250	839	S3	15 - 20 - 25	
		Base Ni o Co	invecchiato	350	1177	S4	10 - 15 - 20	
		Base Ni o Co	da fusione	320	1076	S5	10 - 15 - 20	
	Leghe di Titanio	Titanio puro		200	675	S6	50 - 85 - 120	
		Leghe e , invecchiato		375	1262	S7	30 - 40 - 50	
		Leghe		410	1396	S8	25 - 35 - 45	
	Leghe di tungsteno		300	1013	S9	-		
	Leghe di molibdeno		300	1013	S10	-		
H	Acciaio Temprato	temprato e rinvenuto		50 HRC	-	H1	-	
		temprato e rinvenuto		55 HRC	-	H2	-	
		temprato e rinvenuto		60 HRC	-	H3	-	
	Ghisa Temprata	temprato e rinvenuto		55 HRC	-	H4	-	

I dati indicati in tabella sono valori approssimati.
 Può essere necessario adattarli alle singole applicazioni di lavorazione.
 HC = Metallo duro rivestito

Einsatzempfehlung / Application recommendations / Consigli di utilizzo

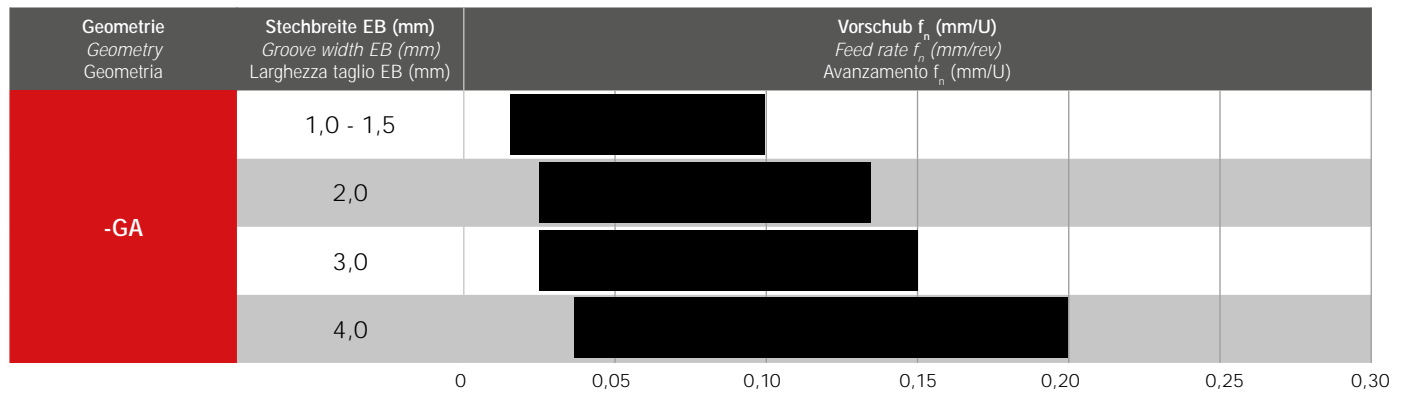

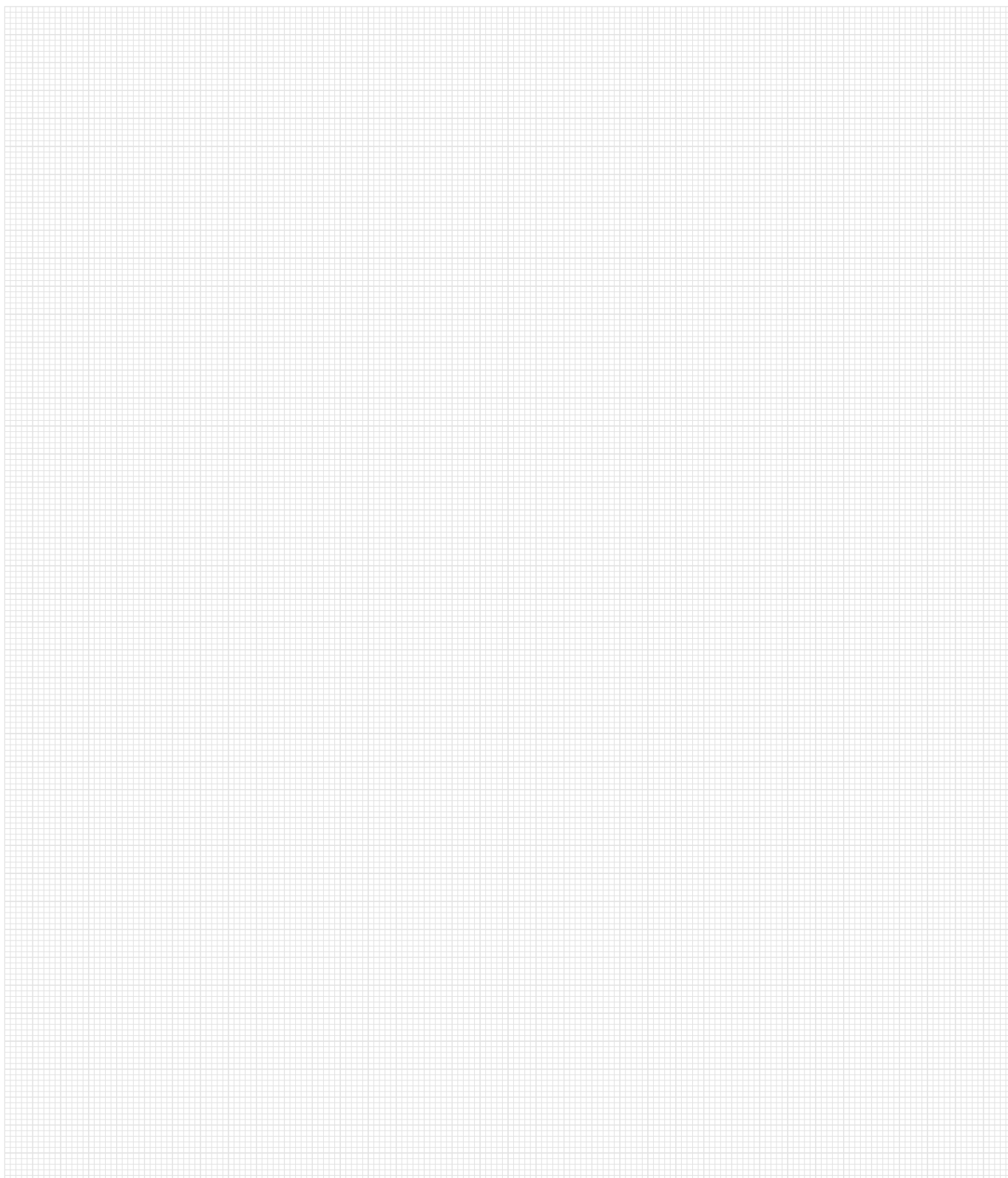

Weitere Informationen finden Sie unter
For more information see
Per maggiori informazioni visita il sito

www.arno.de

Holders with screw clamping
 Steli con fissaggio a vite

HSA-...-ACS1-AFC

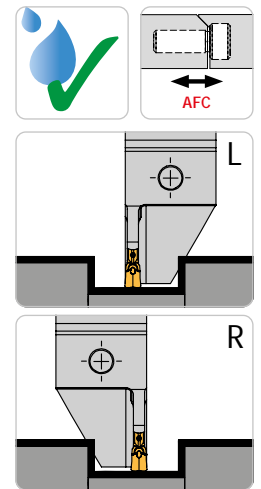
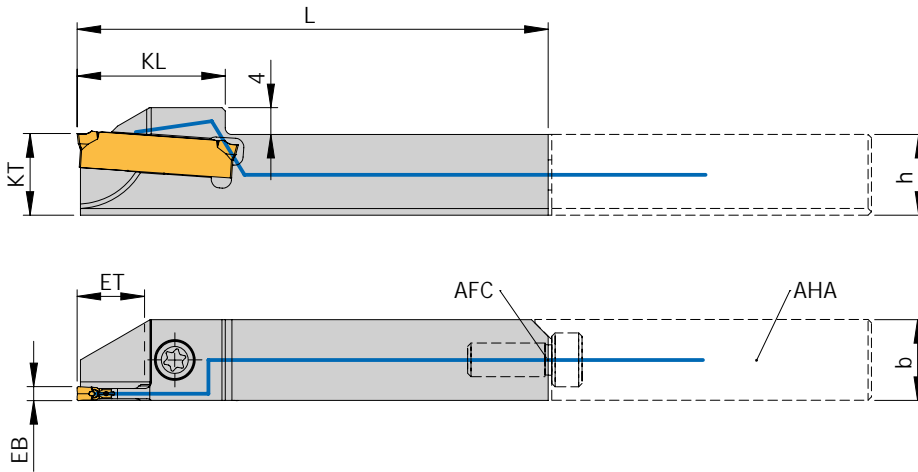

Rechte Ausführung abgebildet
 Right-hand execution shown
 Versione destra in figura

AFC = AFC-Schnittstelle
 AFC = AFC interface
 AFC = Interfaccia AFC

AHA = Anschlag
 AHA = fix stop
 AHA = Fermo



Trägerwerkzeuge / Holders / Utensili

Artikel Article Articolo	EB	ET	D _{max}	h	b	L	KL	KT	Schneideinsatz Insert Inserto
HSA 1212L/R-SA2402-12-ACS1-AFC N	2,0	6	12	12	12	70	18	12	SA24-20...
HSA 1212L/R-SA2402-20-ACS1-AFC	2,0	10	20	12	12	70	22	12	SA24-20...
HSA 1212L/R-SA2402-26-ACS1-AFC	2,0	13	26	12	12	70	25	12	SA24-20...
HSA 1212L/R-SA24025-26-ACS1-AFC N	2,5	13	26	12	12	70	25	12	SA24-25...
HSA 1212L/R-SA2403-26-ACS1-AFC	3,0	13	26	12	12	70	25	12	SA24-30...
HSA 1616L/R-SA2402-20-ACS1-AFC N	2,0	10	20	16	16	70	22	16	SA24-20...
HSA 1616L/R-SA2402-26-ACS1-AFC N	2,0	13	26	16	16	70	25	16	SA24-20...
HSA 1616L/R-SA2402-34-ACS1-AFC N	2,0	17	34	16	16	70	29	16	SA24-20...
HSA 1616L/R-SA2402-42-ACS1-AFC N	2,0	21	42	16	16	70	33	16	SA24-20...
HSA 1616L/R-SA24025-26-ACS1-AFC N	2,5	13	26	16	16	70	25	16	SA24-25...
HSA 1616L/R-SA2403-26-ACS1-AFC N	3,0	13	26	16	16	70	25	16	SA24-30...
HSA 1616L/R-SA2403-34-ACS1-AFC N	3,0	17	34	16	16	70	29	16	SA24-30...
HSA 1616L/R-SA2403-42-ACS1-AFC N	3,0	21	42	16	16	70	33	16	SA24-30...

D_{max} = Maximaler Durchmesser bei Vollmaterial

D_{max} = Maximum diameter in solid

D_{max} = Diametro massimo lavorazione dal pieno



Hinweis: Passende Anschläge finden Sie auf Seite 86 – 89

Remark: For matching fix stops see page 86 – 89

Nota: I fermi compatibili si trovano a pagina 86 – 89

Ersatzteile / Spare Parts / Ricambi

Trägerwerkzeug Holder Utensile	Schraube Screw Vite	Schlüssel Key Chiave	O-Ring O-ring O-ring
HSA 1212L/R-SA...-ACS1-AFC	AS 0022	T5215-IP	OR 4,7X1 FKM80 SCHWARZ
HSA 1616L/R-SA...-ACS1-AFC	AS 0022	T5215-IP	OR 4,7X1,6 NBR70

Holders with screw clamping
 Steli con fissaggio a vite

HSA...-AFC

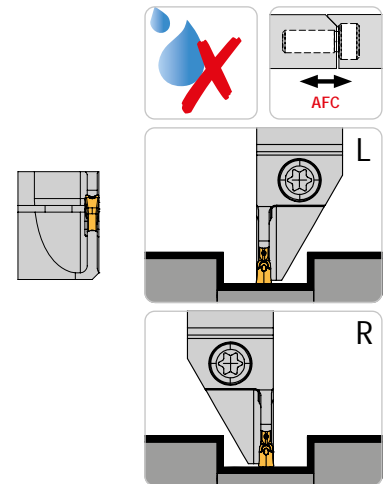
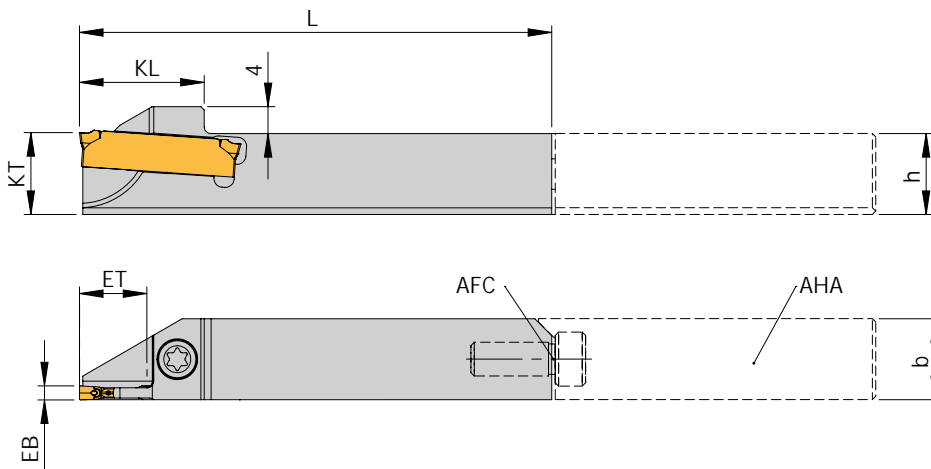

Rechte Ausführung abgebildet
 Right-hand execution shown
 Versione destra in figura

AFC = AFC-Schnittstelle
 AFC = AFC interface
 AFC = Interfaccia AFC

AHA = Anschlag
 AHA = fix stop
 AHA = Fermo



Trägerwerkzeuge / Holders / Utensili

Artikel Article Articolo	EB	ET	D _{max}	h	b	L	KL	KT	Schneideinsatz Insert Inserto
HSA 1212L/R-SA2402-20-AFC	2	10	20	12	12	70	18,5	12	SA24-20...
HSA 1212L/R-SA2402-26-AFC N	2	13	26	12	12	70	21,5	12	SA24-20...

D_{max} = Maximaler Durchmesser bei Vollmaterial

D_{max} = Maximum diameter in solid

D_{max} = Diametro massimo lavorazione dal pieno



Hinweis: Passende Anschläge finden Sie auf Seite 86 – 89

Remark: For matching fix stops see page 86 – 89

Nota: I fermi compatibili si trovano a pagina 86 – 89

Ersatzteile / Spare Parts / Ricambi

Trägerwerkzeug Holder Utensile	Schraube Screw Vite	Schlüssel Key Chiave	O-Ring O-ring O-ring
HSA 1212L/R-SA...-AFC	AS 0022	T5215-IP	OR 4,7X1 FKM80 SCHWARZ

Holders with screw clamping
 Steli con fissaggio a vite

HSA-...U...-AFC

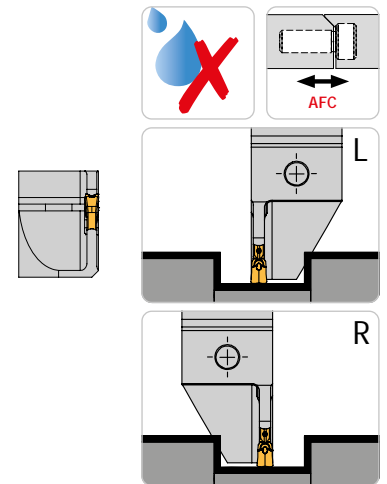
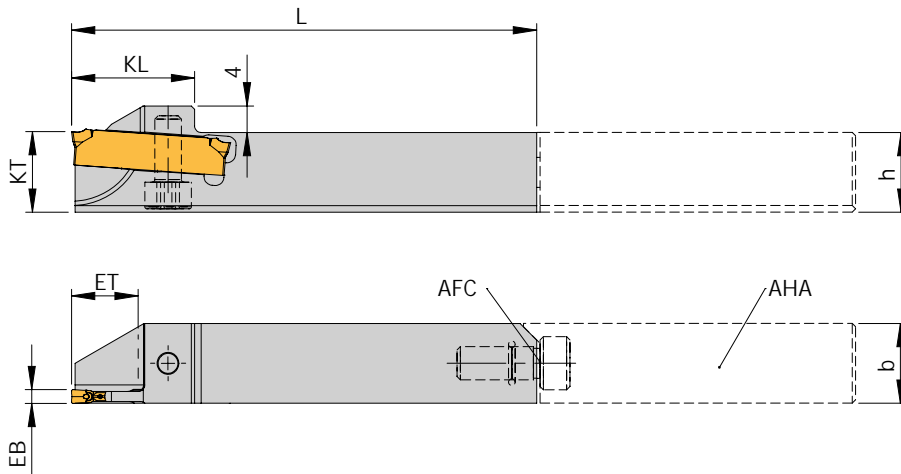

Rechte Ausführung abgebildet
 Right-hand execution shown
 Versione destra in figura

AFC = AFC-Schnittstelle
 AFC = AFC interface
 AFC = Interfaccia AFC

AHA = Anschlag
 AHA = fix stop
 AHA = Fermo

Trägerwerkzeuge / Holders / Utensili

Artikel Article Articolo	EB	ET	D _{max}	L	KL	KT	Schneideinsatz Insert Inserto
HSA 1212U-L/R-SA24015-20-AFC	1,5	10	20	70	18,5	12	SA24-15...
HSA 1212U-L/R-SA2402-12-AFC	2,0	6	12	70	14,5	12	SA24-20...
HSA 1212U-L/R-SA2402-20-AFC	2,0	10	20	70	18,5	12	SA24-20...
HSA 1212U-L/R-SA2402-26-AFC	2,0	13	26	70	21,5	12	SA24-20...

D_{max} = Maximaler Durchmesser bei Vollmaterial

D_{max} = Maximum diameter in solid

D_{max} = Diametro massimo lavorazione dal pieno



Hinweis: Passende Anschläge finden Sie auf Seite 86 – 89

Remark: For matching fix stops see page 86 – 89

Nota: I fermi compatibili si trovano a pagina 86 – 89

Ersatzteile / Spare Parts / Ricambi

Trägerwerkzeug Holder Utensile	Schraube Screw Vite	Schlüssel Key Chiave	O-Ring O-ring O-ring
HSA 1212U-L/R-SA...-AFC	DIN912-M4X10-12.9	KP 1111	OR 4,7X1 FKM80 SCHWARZ

Holders with screw clamping
 Steli con fissaggio a vite

HSE...-ACS1-AFC

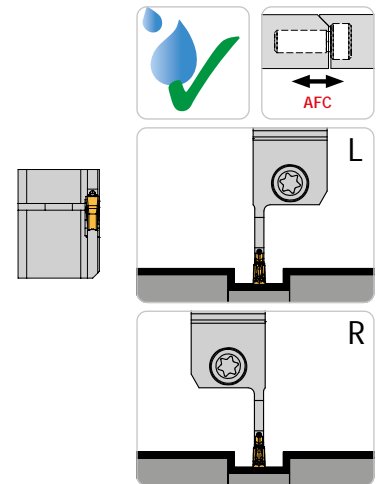
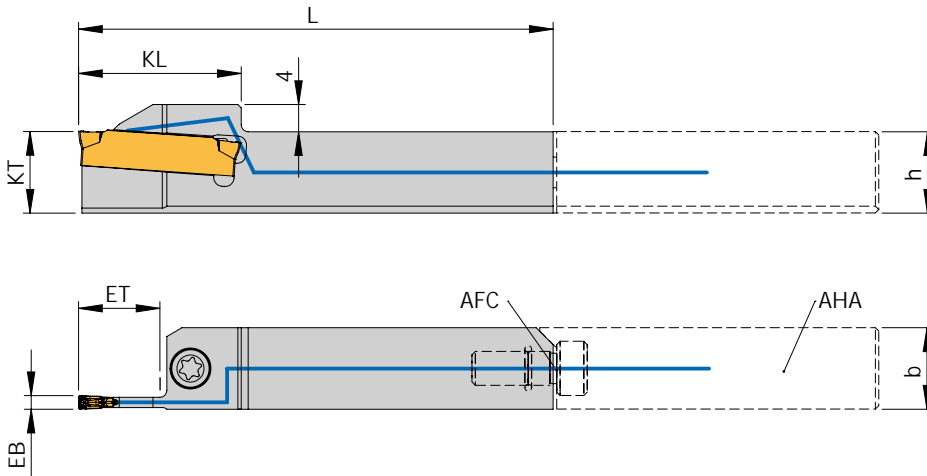

Rechte Ausführung abgebildet
 Right-hand execution shown
 Versione destra in figura

AFC = AFC-Schnittstelle
 AFC = AFC interface
 AFC = Interfaccia AFC

AHA = Anschlag
 AHA = fix stop
 AHA = Fermo



Trägerwerkzeuge / Holders / Utensili

Artikel Article Articolo	EB	ET	h	b	L	KL	KT	Schneideinsatz Insert Inserto
HSE 1212L/R-SE2402-ET12-ACS1-AFC	2	12	12	12	70	24	12	SE24-20...
HSE 1212R-SE2403-ET12-ACS1-AFC	3	12	12	12	70	24	12	SE24-30...
HSE 1616R-SE2403-ET12-ACS1-AFC N	3	12	16	16	70	24	16	SE24-30...



Hinweis: Passende Anschläge finden Sie auf Seite 86 – 89
 Remark: For matching fix stops see page 86 – 89
 Nota: I fermi compatibili si trovano a pagina 86 – 89

Ersatzteile / Spare Parts / Ricambi

Trägerwerkzeug Holder Utensile	Schraube Screw Vite	Schlüssel Key Chiave	O-Ring O-ring O-ring
HSE 1212L/R-SE...-ACS1-AFC	AS 0022	T5215-IP	OR 4,7X1 FKM80 SCHWARZ
HSE 1616R-SE...-ACS1-AFC	AS 0022	T5215-IP	OR 4,7X1,6 NBR70

SCAC L/R ...-IK-AFC

mit Innenkühlung – Anstellwinkel 90,0° / with through tool coolant – Approach angle 90,0° / Con adduzione interna – Angolo di attacco 90,0°

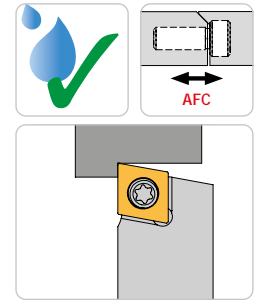

Rechte Ausführung abgebildet
 Right-hand execution shown
 Versione destra in figura

AFC = AFC-Schnittstelle
 AFC = AFC interface
 AFC = Interfaccia AFC

AHA = Anschlag
 AHA = fix stop
 AHA = Fermo

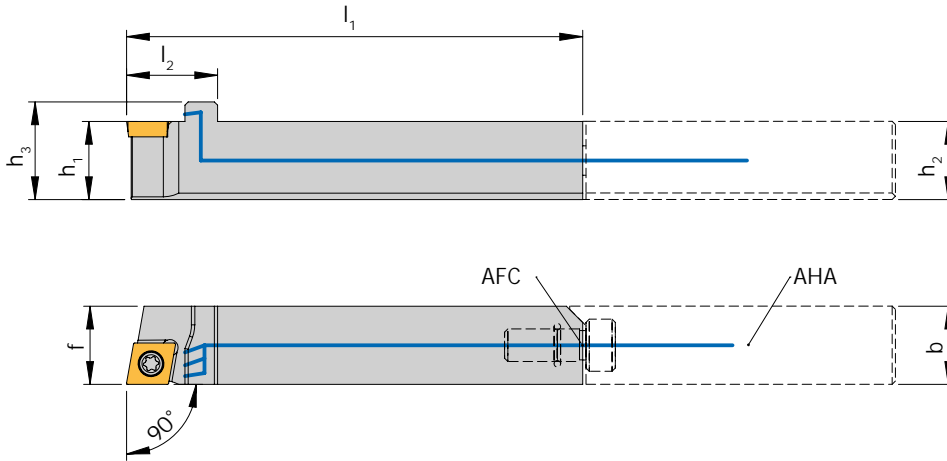

Trägerwerkzeuge / Holders / Utensili

Bezeichnung Designation Articolo	h1 / h2	h3	b	l ₁	l ₂	f	Schneideinsatz Insert Inserto
SCACR 1212 E06-IK-AFC	12	15	12	70	14	12	CC.. 0602...
SCACR 1212 E09-IK-AFC	12	15	12	70	18	12	CC.. 09T3...
SCACL/R 1616 E09-IK-AFC N	16	19	16	70	18	16	CC.. 09T3...



Hinweis: Passende Anschläge finden Sie auf Seite 86 – 89

Remark: For matching fix stops see page 86 – 89

Nota: I fermi compatibili si trovano a pagina 86 – 89

Ersatzteile / Spare Parts / Ricambi

Trägerwerkzeug Holder Utensile	Schraube Screw Vite	Schlüssel Key Chiave	O-Ring O-ring O-ring
SCACR 1212 E06-IK-AFC	SS 1751	KS 1751	OR 4,7X1 FKM80 SCHWARZ
SCACR 1212 E09-IK-AFC	SS 1111	KS 1111	OR 4,7X1 FKM80 SCHWARZ
SCACL/R 1616 E09-IK-AFC	SS 1111	KS 1111	OR 4,7X1,6 NBR70

SCAC R ...-AFC

Anstellwinkel 90° / Approach angle 90° / Angolo di attacco 90°

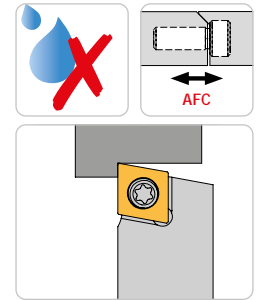
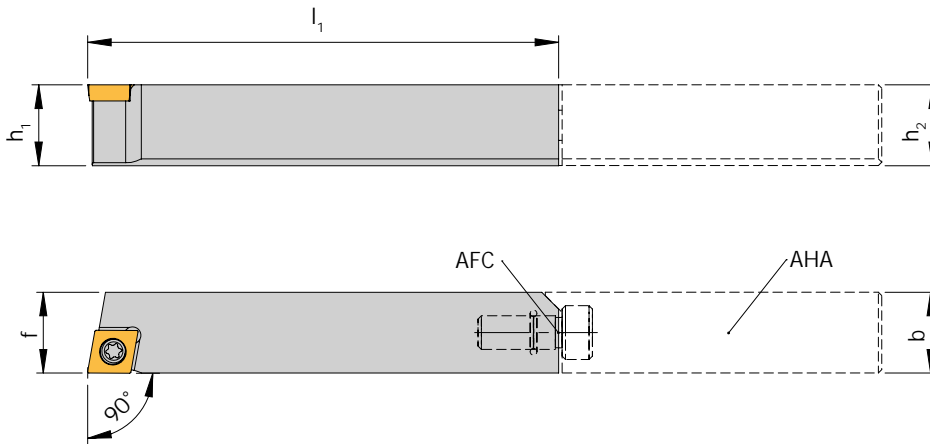

Rechte Ausführung abgebildet
 Right-hand execution shown
 Versione destra in figura

AFC = AFC-Schnittstelle
 AFC = AFC interface
 AFC = Interfaccia AFC

AHA = Anschlag
 AHA = fix stop
 AHA = Fermo

Trägerwerkzeuge / Holders / Utensili

Bezeichnung Designation Articolo	h1 / h2	h3	b ₁	l ₁	f	Schneideinsatz Insert Inserto
SCACR 1212 E06-AFC	12	12	12	70	12	CC.. 0602...
SCACR 1212 E09-AFC	12	12	12	70	12	CC.. 09T3...



Hinweis: Passende Anschläge finden Sie auf Seite 86 – 89

Remark: For matching fix stops see page 86 – 89

Nota: I fermi compatibili si trovano a pagina 86 – 89

Ersatzteile / Spare Parts / Ricambi

Trägerwerkzeug Holder Utensile	Schraube Screw Vite	Schlüssel Key Chiave	O-Ring O-ring O-ring
SCACR 1212 E06-AFC	SS 1751	KS 1751	OR 4,7X1 FKM80 SCHWARZ
SCACR 1212 E09-AFC	SS 1111	KS 1111	OR 4,7X1 FKM80 SCHWARZ

SCLC L/R ...-IK-AFC

mit Innenkühlung – Anstellwinkel 95° / with through tool coolant – Approach angle 95° / Con adduzione interna – Angolo di attacco 95°

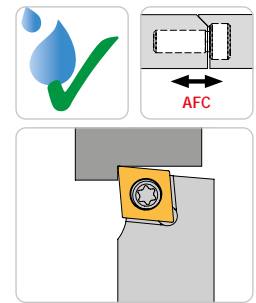

Rechte Ausführung abgebildet
 Right-hand execution shown
 Versione destra in figura

AFC = AFC-Schnittstelle
 AFC = AFC interface
 AFC = interfaccia AFC

AHA = Anschlag
 AHA = fix stop
 AHA = fermo

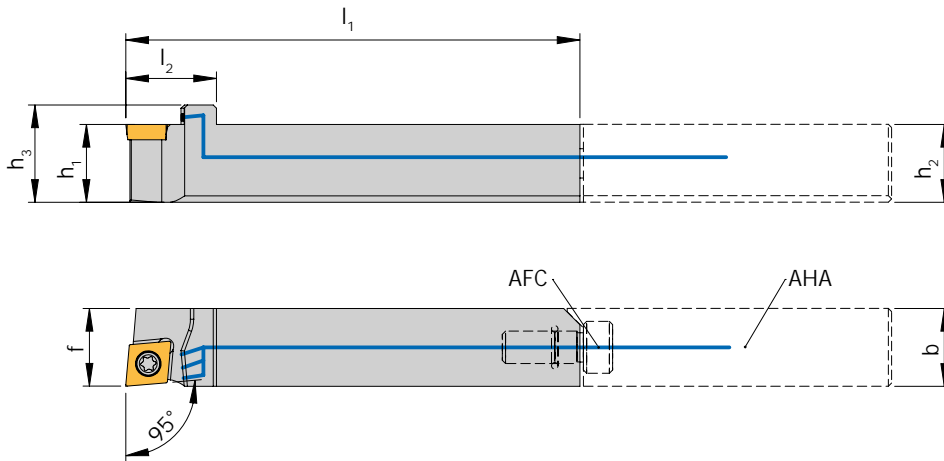

Trägerwerkzeuge / Holders / Utensili

Bezeichnung Designation Articolo	h1 / h2	h3	b	l ₁	l ₂	f	Schneideinsatz Insert Inserto
SCLCR 1212 E06-IK-AFC	12	15	12	70	14	12	CC.. 0602...
SCLCL/R 1212 E09-IK-AFC	12	15	12	70	18	12	CC.. 09T3...
SCLCL/R 1616 E06-IK-AFC N	16	19	16	70	14	16	CC.. 0602...
SCLCL/R 1616 E09-IK-AFC N	16	19	16	70	18	16	CC.. 09T3...
SCLCL/R 1616 E12-IK-AFC N	16	19	16	70	22	16	CC.. 1204...



Hinweis: Passende Anschläge finden Sie auf Seite 86 – 89

Remark: For matching fix stops see page 86 – 89

Nota: I fermi compatibili si trovano a pagina 86 – 89

Ersatzteile / Spare Parts / Ricambi

Trägerwerkzeug Holder Utensile	Schraube Screw Vite	Schlüssel Key Chiave	O-Ring O-ring O-ring
SCLCR 1212 E06-IK-AFC	SS 1751	KS 1751	OR 4,7X1 FKM80 SCHWARZ
SCLCL/R 1212 E09-IK-AFC	SS 1111	KS 1111	OR 4,7X1 FKM80 SCHWARZ
SCLCL/R 1616 E06-IK-AFC	SS 1751	KS 1751	OR 4,7X1,6 NBR70
SCLCL/R 1616 E09-IK-AFC	SS 1111	KS 1111	OR 4,7X1,6 NBR70
SCLCL/R 1616 E12-IK-AFC	SS 1221	KS 1115	OR 4,7X1,6 NBR70

SCLC L/R ...-AFC

mit Innenkühlung – Anstellwinkel 95° / with through tool coolant – Approach angle 95° / Con adduzione interna – Angolo di attacco 95°

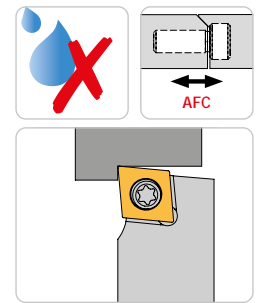

Rechte Ausführung abgebildet
 Right-hand execution shown
 Versione destra in figura

AFC = AFC-Schnittstelle
 AFC = AFC interface
 AFC = Interfaccia AFC

AHA = Anschlag
 AHA = fix stop
 AHA = Fermo

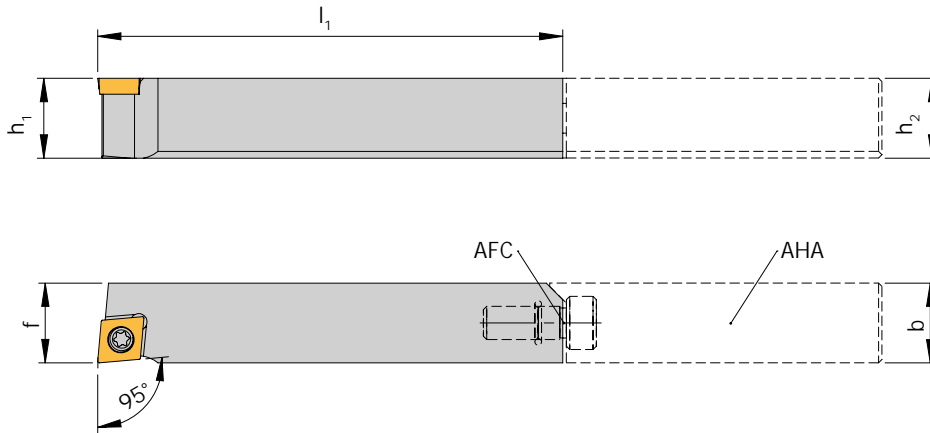

Trägerwerkzeuge / Holders / Utensili

Bezeichnung Designation Articolo	h1 / h2	h3	b ₁	l ₁	f	Schneideinsatz Insert Inserto
SCLCR 1212 E06-AFC	12	12	12	70	12	CC.. 0602...
SCLCL/R 1212 E09-AFC	12	12	12	70	12	CC.. 09T3...



Hinweis: Passende Anschläge finden Sie auf Seite 86 – 89

Remark: For matching fix stops see page 86 – 89

Nota: I fermi compatibili si trovano a pagina 86 – 89

Ersatzteile / Spare Parts / Ricambi

Trägerwerkzeug Holder Utensile	Schraube Screw Vite	Schlüssel Key Chiave	O-Ring O-ring O-ring
SCLCR 1212 E06-AFC	SS 1751	KS 1751	OR 4,7X1 FKM80 SCHWARZ
SCLCL/R 1212 E09-AFC	SS 1111	KS 1111	OR 4,7X1 FKM80 SCHWARZ

SCLC R ...-F03-IK-AFC

mit Innenkühlung – Anstellwinkel 95° / with through tool coolant – Approach angle 95°
 / Con adduzione interna – Angolo di attacco 95°

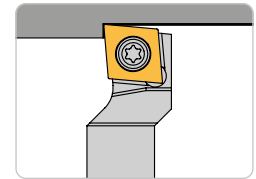

Rechte Ausführung abgebildet
 Right-hand execution shown
 Versione destra in figura

AFC = AFC-Schnittstelle
 AFC = AFC interface
 AFC = Interfaccia AFC

AHA = Anschlag
 AHA = fix stop
 AHA = Fermo

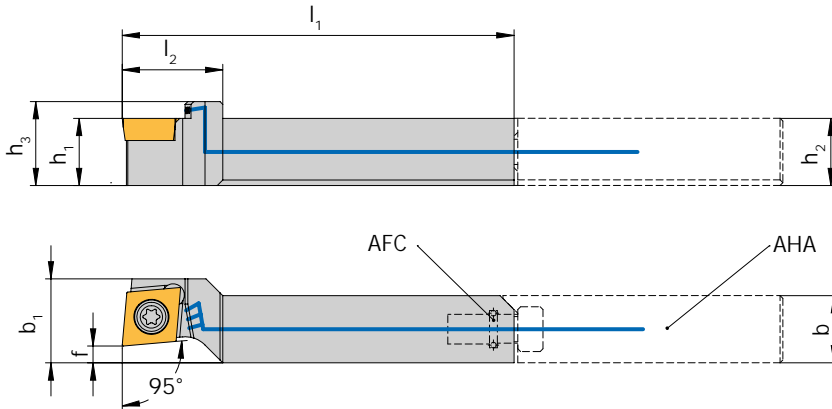

Trägerwerkzeuge / Holders / Utensili

Bezeichnung Designation Articolo	h1 / h2	h3	b	b ₁	l ₁	l ₂	f	Schneideinsatz Insert Inserto
SCLCR 1212 E09-F03-IK-AFC	12	15	12	15	70	18	3	CC.. 09T3...



Hinweis: Passende Anschläge finden Sie auf Seite 86 – 89
 Remark: For matching fix stops see page 86 – 89
 Nota: I fermi compatibili si trovano a pagina 86 – 89

Ersatzteile / Spare Parts / Ricambi

Trägerwerkzeug Holder Utensile	Schraube Screw Vite	Schlüssel Key Chiave	O-Ring O-ring O-ring
SCLCR 1212 E09-F03-IK-AFC	SS 1111	KS 1111	OR 4,7X1 FKM80 SCHWARZ

SD91C L/R ...-IK-AFC

mit Innenkühlung – Anstellwinkel 91° / with through tool coolant – Approach angle 91° / Con adduzione interna – Angolo di attacco 91°

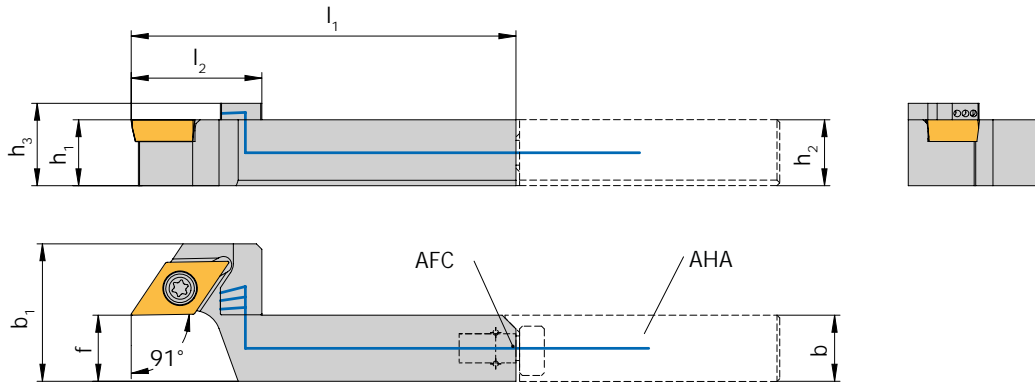
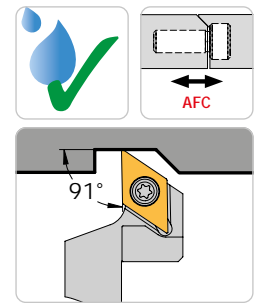

Rechte Ausführung abgebildet
 Right-hand execution shown
 Versione destra in figura

AFC = Schnittstelle
 AFC = interface
 AFC = interfaccia
 AHA = Anschlag
 AHA = fix stop
 AHA = fermo

Trägerwerkzeuge / Holders / Utensili

Bezeichnung Designation Articolo	h1 / h2	h3	b	b ₁	l ₁	l ₂	f	Schneideinsatz Insert Inserto
SD91CL/R 1212 E11-IK-AFC	12	15	12	25	70	24	12	DC.. 11T3...



Hinweis: Passende Anschläge finden Sie auf Seite 86 – 89

Remark: For matching fix stops see page 86 – 89

Nota: I fermi compatibili si trovano a pagina 86 – 89

Ersatzteile / Spare Parts / Ricambi

Trägerwerkzeug Holder Utensile	Schraube Screw Vite	Schlüssel Key Chiave	O-Ring O-ring O-ring
SD91CL/R 1212 E11-IK-AFC	SS 1111	KS 1111	OR 4,7X1 FKM80 SCHWARZ

SDAC L/R ...-IK-AFC

mit Innenkühlung – Anstellwinkel 90,0° / with through tool coolant – Approach angle 90,0° / Con adduzione interna – Angolo di attacco 90,0°

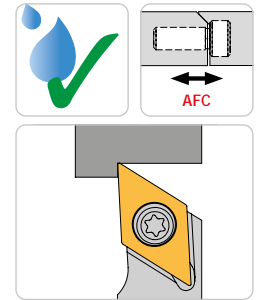
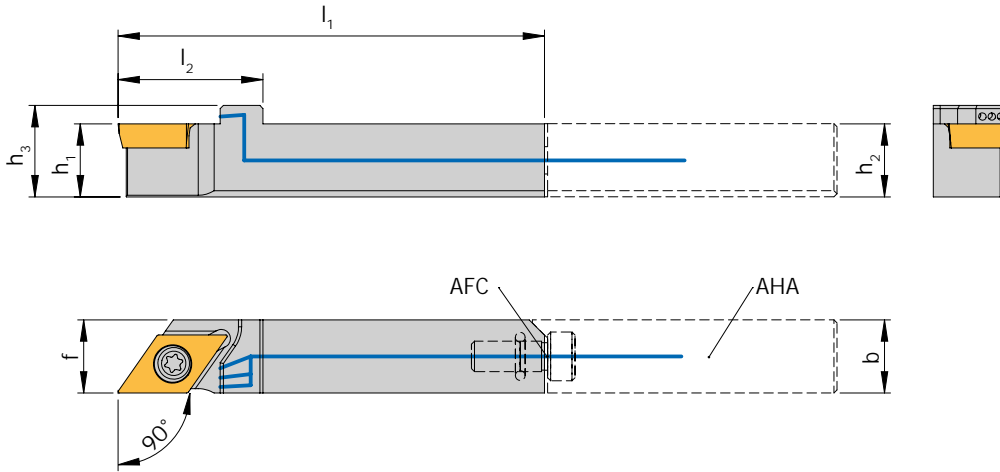

Rechte Ausführung abgebildet
 Right-hand execution shown
 Versione destra in figura

AFC = Schnittstelle
 AFC = interface
 AFC = Interfaccia
 AHA = Anschlag
 AHA = fix stop
 AHA = Fermo



Trägerwerkzeuge / Holders / Utensili

Bezeichnung Designation Articolo	h1 / h2	h3	b	l ₁	l ₂	f	Schneideinsatz Insert Inserto
SDACR 1212 E11-IK-AFC	12	15	12	70	24	12	DC.. 11T3...
SDACL/R 1616 E11-IK-AFC N	16	19	16	70	24	16	DC.. 11T3...



Hinweis: Passende Anschläge finden Sie auf Seite 86 – 89
 Remark: For matching fix stops see page 86 – 89
 Nota: I fermi compatibili si trovano a pagina 86 – 89

Ersatzteile / Spare Parts / Ricambi

Trägerwerkzeug Holder Utensile	Schraube Screw Vite	Schlüssel Key Chiave	O-Ring O-ring O-ring
SDACR 1212 E11-IK-AFC	SS 1111	KS 1111	OR 4,7X1 FKM80 SCHWARZ
SDACL/R 1616 E11-IK-AFC	SS 1111	KS 1111	OR 4,7X1,6 NBR70

SDAC R ...-AFC

mit Innenkühlung – Anstellwinkel 90,0° / with through tool coolant – Approach angle 90,0° / Con adduzione interna – Angolo di attacco 90,0°

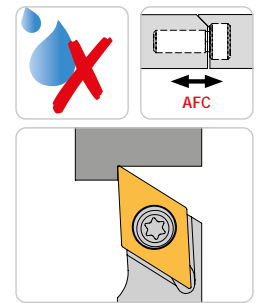

Rechte Ausführung abgebildet
 Right-hand execution shown
 Versione destra in figura

AFC = Schnittstelle
 AFC = interfaccia
 AHA = Anschlag
 AHA = fix stop
 AHA = Fermo

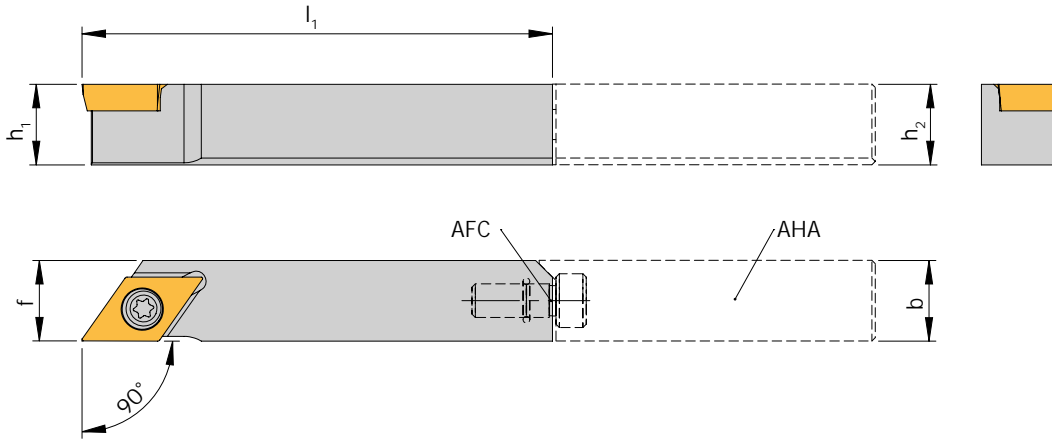

Trägerwerkzeuge / Holders / Utensili

Bezeichnung Designation Articolo	h1 / h2	h3	b	b ₁	l ₁	f	Schneideinsatz Insert Inserto
SDACR 1212 E11-AFC	12	12	12	12	70	12	DC.. 11T3...



Hinweis: Passende Anschläge finden Sie auf Seite 86 – 89
 Remark: For matching fix stops see page 86 – 89
 Nota: I fermi compatibili si trovano a pagina 86 – 89

Ersatzteile / Spare Parts / Ricambi

Trägerwerkzeug Holder Utensile	Schraube Screw Vite	Schlüssel Key Chiave	O-Ring O-ring O-ring
SDACR 1212 E11-AFC	SS 1111	KS 1111	OR 4,7X1 FKM80 SCHWARZ

SDHC L/R ...-IK-AFC

mit Innenkühlung – Anstellwinkel 107,5° / with through tool coolant – Approach angle 107,5° / Con adduzione interna – Angolo di attacco 107,5°

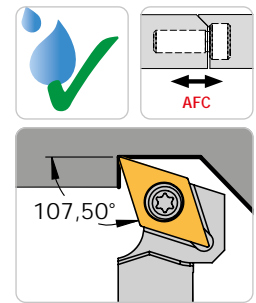

Rechte Ausführung abgebildet
 Right-hand execution shown
 Versione destra in figura

AFC = Schnittstelle
 AFC = interface
 AFC = Interfaccia
 AHA = Anschlag
 AHA = fix stop
 AHA = Fermo

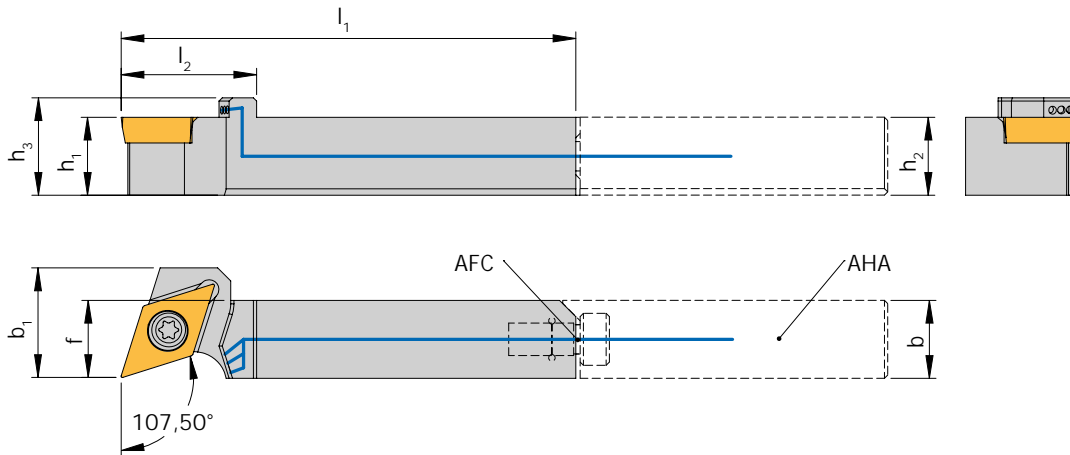

Trägerwerkzeuge / Holders / Utensili

Bezeichnung Designation Articolo	h1 / h2	h3	b	b ₁	l ₁	l ₂	f	Schneideinsatz Insert Inserto
SDHCL/R 1212 E11-IK-AFC	12	15	12	17	70	21	12	DC.. 11T3...



Hinweis: Passende Anschläge finden Sie auf Seite 86 – 89
 Remark: For matching fix stops see page 86 – 89
 Nota: I fermi compatibili si trovano a pagina 86 – 89

Ersatzteile / Spare Parts / Ricambi

Trägerwerkzeug Holder Utensile	Schraube Screw Vite	Schlüssel Key Chiave	O-Ring O-ring O-ring
SDHCL/R 1212 E11-IK-AFC	SS 1111	KS 1111	OR 4,7X1 FKM80 SCHWARZ

SDJC L/R ...-IK-AFC

mit Innenkühlung – Anstellwinkel 93° / with through tool coolant – Approach angle 93° / Con adduzione interna – Angolo di attacco 93°

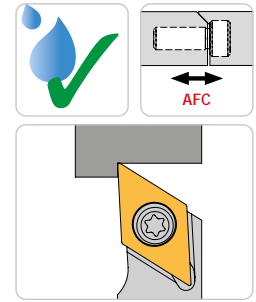
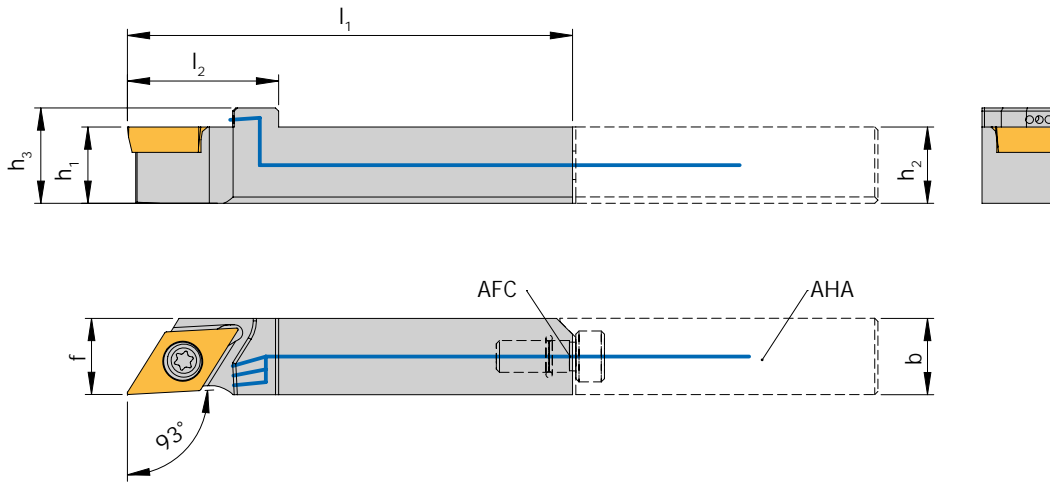

Rechte Ausführung abgebildet
 Right-hand execution shown
 Versione destra in figura

AFC = Schnittstelle
 AFC = interface
 AFC = Interfaccia
 AHA = Anschlag
 AHA = fix stop
 AHA = Fermo

N NEU/NEW/NUOVO

Trägerwerkzeuge / Holders / Utensili

Bezeichnung Designation Articolo	h1 / h2	h3	b	l ₁	l ₂	f	Schneideinsatz Insert Inserto
SDJCL/R 1212 E07- IK-AFC	12	15	12	70	18	12	DC.. 0702...
SDJCL/R 1212 E11- IK-AFC	12	15	12	70	24	12	DC.. 11T3...
SDJCL/R 1616 E07- IK-AFC N	16	19	16	70	18	16	DC.. 0702...
SDJCL/R 1616 E11- IK-AFC N	16	19	16	70	24	16	DC.. 11T3...



Hinweis: Passende Anschläge finden Sie auf Seite 86 – 89

Remark: For matching fix stops see page 86 – 89

Nota: I fermi compatibili si trovano a pagina 86 – 89

Ersatzteile / Spare Parts / Ricambi

Trägerwerkzeug Holder Utensile	Schraube Screw Vite	Schlüssel Key Chiave	O-Ring O-ring O-ring
SDJCL/R 1212 E07- IK-AFC	SS 1751	KS 1751	OR 4,7X1 FKM80 SCHWARZ
SDJCL/R 1212 E11- IK-AFC	SS 1111	KS 1111	OR 4,7X1 FKM80 SCHWARZ
SDJCL/R 1616 E07- IK-AFC	SS 1751	KS 1751	OR 4,7X1,6 NBR70
SDJCL/R 1616 E11- IK-AFC	SS 1111	KS 1111	OR 4,7X1,6 NBR70

SDJC L/R ...-AFC

Anstellwinkel 93° / Approach angle 93° / Angolo di attacco 93°

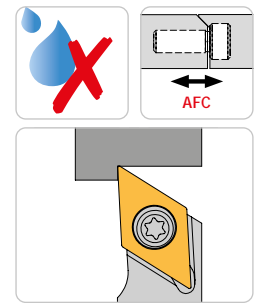

Rechte Ausführung abgebildet
 Right-hand execution shown
 Versione destra in figura

AFC = Schnittstelle
 AFC = interface
 AFC = Interfaccia

AHA = Anschlag
 AHA = fix stop
 AHA = Fermo

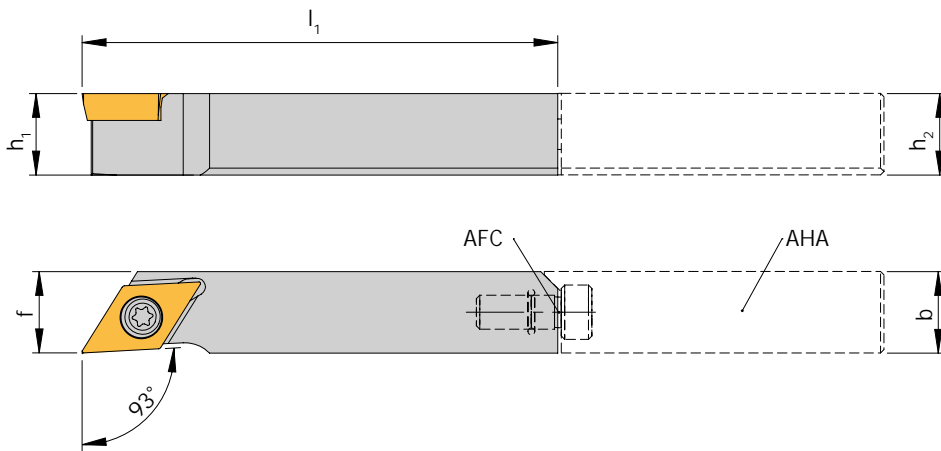

Trägerwerkzeuge / Holders / Utensili

Bezeichnung Designation Articolo	h1 / h2	h3	b	b ₁	l ₁	f	Schneideinsatz Insert Inserto
SDJCL/R 1212 E07-AFC	12	12	12	12	70	12	DC.. 0702...
SDJCL/R 1212 E11-AFC	12	12	12	12	70	12	DC.. 11T3...



Hinweis: Passende Anschläge finden Sie auf Seite 86 – 89
 Remark: For matching fix stops see page 86 – 89
 Nota: I fermi compatibili si trovano a pagina 86 – 89

Ersatzteile / Spare Parts / Ricambi

Trägerwerkzeug Holder Utensile	Schraube Screw Vite	Schlüssel Key Chiave	O-Ring O-ring O-ring
SDJCL/R 1212 E07-IK-AFC	SS 1751	KS 1751	OR 4,7X1 FKM80 SCHWARZ
SDJCL/R 1212 E11-IK-AFC	SS 1111	KS 1111	OR 4,7X1 FKM80 SCHWARZ

SDNCN ...-IK-AFC

mit Innenkühlung – Anstellwinkel 62,5° / with through tool coolant – Approach angle 62,5° / Con adduzione interna – Angolo di attacco 62,5°

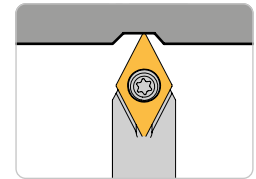
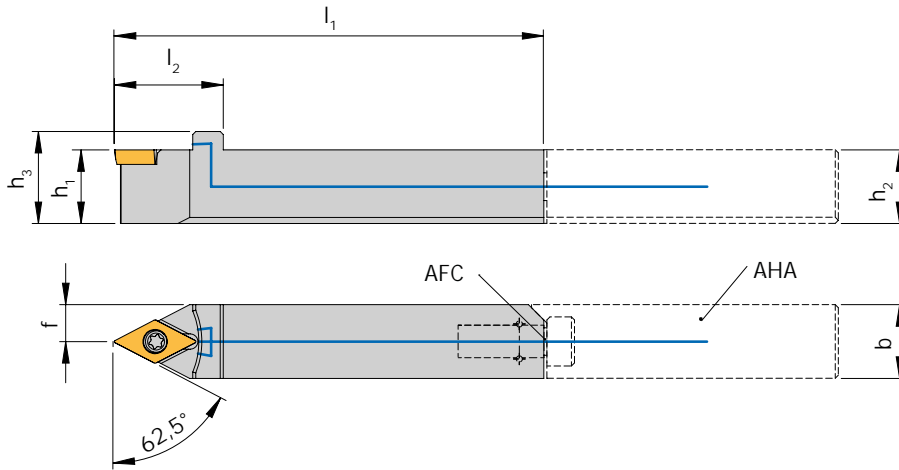

Rechte Ausführung abgebildet
 Right-hand execution shown
 Versione destra in figura

AFC = Schnittstelle
 AFC = interface
 AFC = Interfaccia
 AHA = Anschlag
 AHA = fix stop
 AHA = Fermo



Trägerwerkzeuge / Holders / Utensili

Bezeichnung Designation Articolo	h1 / h2	h3	b	l ₁	l ₂	f	Schneideinsatz Insert Inserto
SDNCN 1212 E07- IK-AFC	12	15	12	70	18	6	DC.. 0702...
SDNCN 1212 E11- IK-AFC	12	15	12	70	25	6	DC.. 11T3...
SDNCN 1616 E11- IK-AFC N	16	19	16	70	25	8	DC 11T3...



Hinweis: Passende Anschläge finden Sie auf Seite 86 – 89
 Remark: For matching fix stops see page 86 – 89
 Nota: I fermi compatibili si trovano a pagina 86 – 89

Ersatzteile / Spare Parts / Ricambi

Trägerwerkzeug Holder Utensile	Schraube Screw Vite	Schlüssel Key Chiave	O-Ring O-ring O-ring
SDNCN 1212 E07- IK-AFC	SS 1751	KS 1751	OR 4,7X1 FKM80 SCHWARZ
SDNCN 1212 E11- IK-AFC	SS 1111	KS 1111	OR 4,7X1 FKM80 SCHWARZ
SDNCN 1616 E11- IK-AFC	SS 1111	KS 1111	OR 4,7X1,6 NBR70

SV91C R ...-IK-AFC

zum Rückwärtsdrehen - mit Innenkühlung / for back turning - with through tool coolant / per la lavorazione in tirata - con adduzione interna del refrigerante

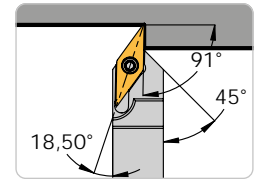

Rechte Ausführung abgebildet
 Right-hand execution shown
 Versione destra in figura

AFC = Schnittstelle
 AFC = interface
 AFC = Interfaccia
 AHA = Anschlag
 AHA = fix stop
 AHA = Fermo

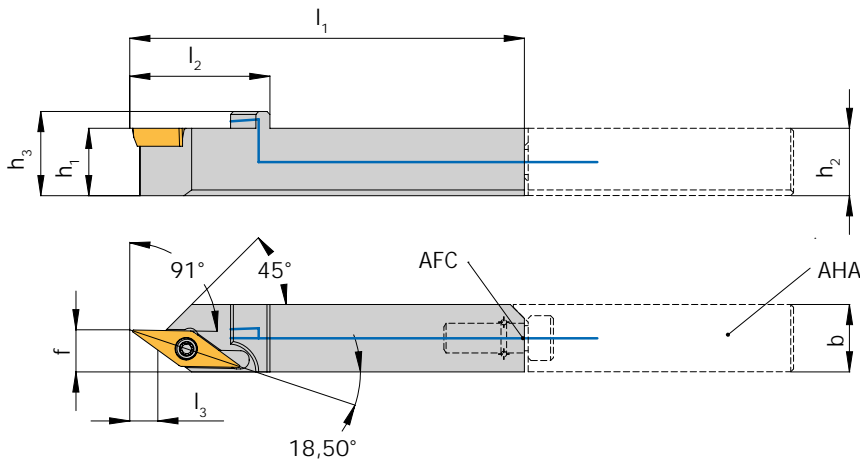

Trägerwerkzeuge / Holders / Utensili

Bezeichnung Designation Articolo	h1 / h2	h3	b	l ₁	l ₂	l ₃	f	Schneideinsatz Insert Inserto
SV91CR 1212 E11-IK-AFC	12	15	12	70	25	5	7,5	VC.. 1103...



Hinweis: Passende Anschläge finden Sie auf Seite 86 – 89

Remark: For matching fix stops see page 86 – 89

Nota: I fermi compatibili si trovano a pagina 86 – 89

Ersatzteile / Spare Parts / Ricambi

Trägerwerkzeug Holder Utensile	Schraube Screw Vite	Schlüssel Key Chiave	O-Ring O-ring O-ring
SV91CR 1212 E11-IK-AFC	SS 1751	KS 1751	OR 4,7X1 FKM80 SCHWARZ

SVJC L/R ...-IK-AFC

Anstellwinkel 93° / Approach angle 93° / Angolo di attacco 93°

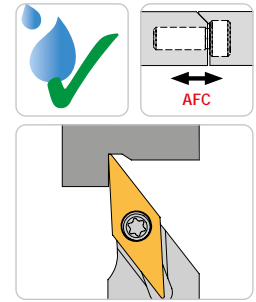
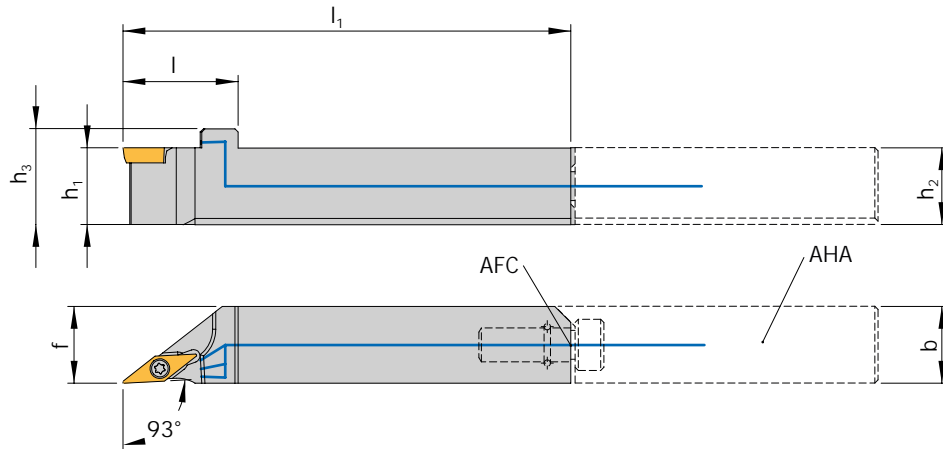

Rechte Ausführung abgebildet
 Right-hand execution shown
 Versione destra in figura

AFC = Schnittstelle
 AFC = Interfaccia

AHA = Anschlag
 AHA = fix stop
 AHA = Fermo



Trägerwerkzeuge / Holders / Utensili

Bezeichnung Designation Articolo	h1 / h2	h3	b	l ₁	l ₂	f	Schneideinsatz Insert Inserto
SVJCL/R 1212 E07- IK-AFC	12	15	12	70	18	12	VC.. 0702...
SVJCL/R 1212 E11- IK-AFC	12	15	12	70	24	12	VC.. 1103...
SVJCL/R 1212 E13- IK-AFC	12	15	12	70	30	12	VC.. 1303...
SVJCL/R 1616 E11- IK-AFC N	16	19	16	70	24	16	VC.. 1103...
SVJCL/R 1616 E13- IK-AFC N	16	19	16	70	30	16	VC.. 1303...
SVJCL/R 1616 E16- IK-AFC N	16	19	16	70	34	16	VC.. 1604...



Hinweis: Passende Anschläge finden Sie auf Seite 86 – 89
 Remark: For matching fix stops see page 86 – 89
 Nota: I fermi compatibili si trovano a pagina 86 – 89

Ersatzteile / Spare Parts / Ricambi

Trägerwerkzeug Holder Utensile	Schraube Screw Vite	Schlüssel Key Chiave	O-Ring O-ring O-ring
SVJCL/R 1212 E07- IK-AFC	SS 5140	KS 1886	OR 4,7X1 FKM80 SCHWARZ
SVJCL/R 1212 E11- IK-AFC	SS 1751	KS 1751	OR 4,7X1 FKM80 SCHWARZ
SVJCL/R 1212 E13- IK-AFC	SS 8831	KS 1751	OR 4,7X1 FKM80 SCHWARZ
SVJCL/R 1616 E11- IK-AFC	SS 1751	KS 1751	OR 4,7X1,6 NBR70
SVJCL/R 1616 E13- IK-AFC	SS 8831	KS 1751	OR 4,7X1,6 NBR70
SVJCL/R 1616 E16- IK-AFC	SS 1111	KS 1111	OR 4,7X1,6 NBR70

SVJC L/R ...-AFC

Anstellwinkel 93° / Approach angle 93° / Angolo di attacco 93°

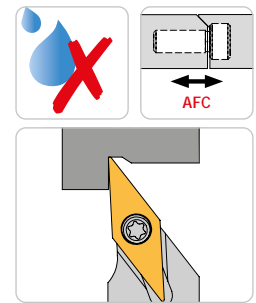

Rechte Ausführung abgebildet
 Right-hand execution shown
 Versione destra in figura

AFC = Schnittstelle
 AFC = interface
 AFC = Interfaccia
 AHA = Anschlag
 AHA = fix stop
 AHA = Fermo

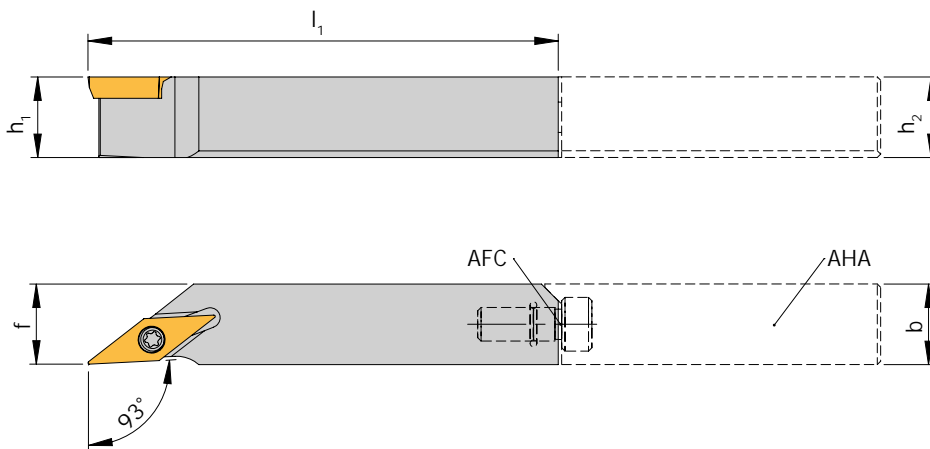

Trägerwerkzeuge / Holders / Utensili

Bezeichnung Designation Articolo	h1 / h2	h3	b ₁	l ₁	f	Schneideinsatz Insert Inserto
SVJCL/R 1212 E11-AFC	12	12	12	70	12	VC.. 1103...



Hinweis: Passende Anschläge finden Sie auf Seite 86 – 89

Remark: For matching fix stops see page 86 – 89

Nota: I fermi compatibili si trovano a pagina 86 – 89

Ersatzteile / Spare Parts / Ricambi

Trägerwerkzeug Holder Utensile	Schraube Screw Vite	Schlüssel Key Chiave	O-Ring O-ring O-ring
SVJCL/R 1212 E11-AFC	SS 1751	KS 1751	OR 4,7X1 FKM80 SCHWARZ

SVVC N ...-IK-AFC

mit Innenkühlung – Anstellwinkel 72,5° / with through tool coolant – Approach angle 72,5° / Con adduzione interna – Angolo di attacco 72,5°

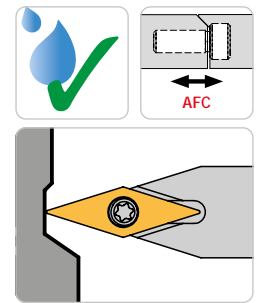

Rechte Ausführung abgebildet
 Right-hand execution shown
 Versione destra in figura

AFC = Schnittstelle
 AFC = interface
 AFC = Interfaccia
 AHA = Anschlag
 AHA = fix stop
 AHA = Fermo

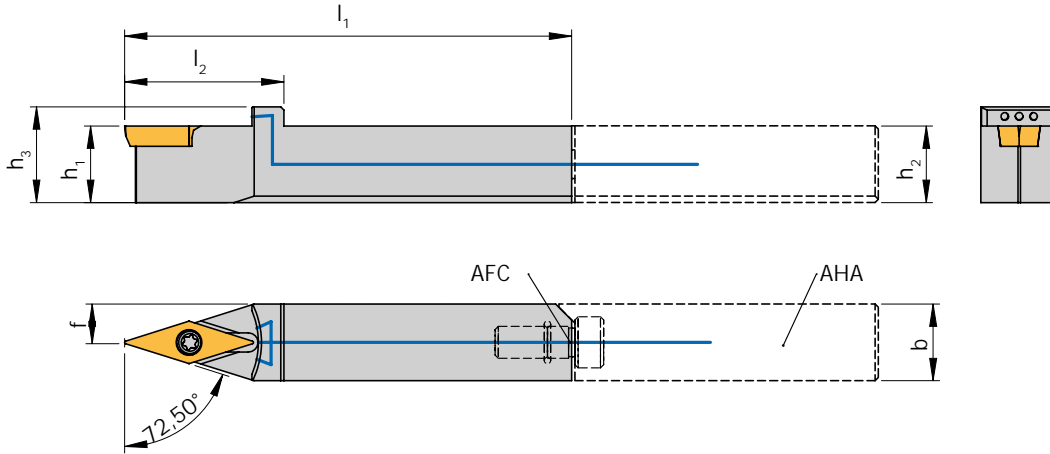

Trägerwerkzeuge / Holders / Utensili

Bezeichnung Designation Articolo	h1 / h2	h3	b	l ₁	l ₂	f	Schneideinsatz Insert Inserto
SVVCN 1212 E11-IK-AFC	12	15	12	70	25	6	VC.. 1103...
SVVCN 1616 E11-IK-AFC N	16	19	16	70	25	8	VC.. 1103...



Hinweis: Passende Anschläge finden Sie auf Seite 86 – 89
 Remark: For matching fix stops see page 86 – 89
 Nota: I fermi compatibili si trovano a pagina 86 – 89

Ersatzteile / Spare Parts / Ricambi

Trägerwerkzeug Holder Utensile	Schraube Screw Vite	Schlüssel Key Chiave	O-Ring O-ring O-ring
SVVCN 1212 E11-IK-AFC	SS 1751	KS 1751	OR 4,7X1 FKM80 SCHWARZ
SVVCN 1616 E11-IK-AFC	SS 1751	KS 1751	OR 4,7X1,6 NBR70

SVVC N ...-AFC

Anstellwinkel 72,5° / Approach angle 72,5° / Angolo di attacco 72,5°

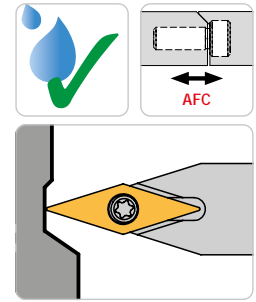
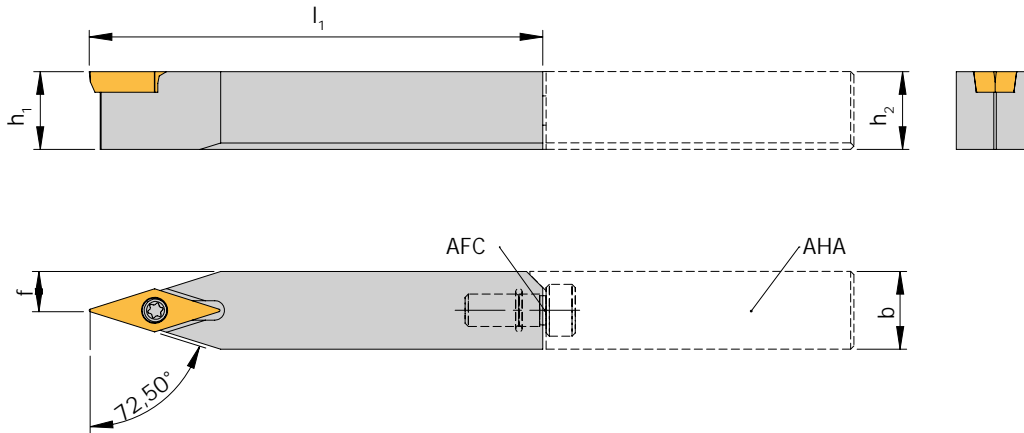

Rechte Ausführung abgebildet
 Right-hand execution shown
 Versione destra in figura

AFC = Schnittstelle
 AFC = interface
 AFC = Interfaccia
 AHA = Anschlag
 AHA = fix stop
 AHA = Fermo

Trägerwerkzeuge / Holders / Utensili

Bezeichnung Designation Articolo	h1 / h2	h3	b	l ₁	l ₂	f	Schneideinsatz Insert Inserto
SVVCN 1212 E11-AFC	12	15	12	70	25	6	VC.. 1103...



Hinweis: Passende Anschläge finden Sie auf Seite 86 – 89

Remark: For matching fix stops see page 86 – 89

Nota: I fermi compatibili si trovano a pagina 86 – 89

Ersatzteile / Spare Parts / Ricambi

Trägerwerkzeug Holder Utensile	Schraube Screw Vite	Schlüssel Key Chiave	O-Ring O-ring O-ring
SVVCN 1212 E11-AFC	SS 1751	KS 1751	OR 4,7X1 FKM80 SCHWARZ

AL ...-3R-IK-AFC

mit Innenkühlung / with through tool coolant / con adduzione interna del refrigerante

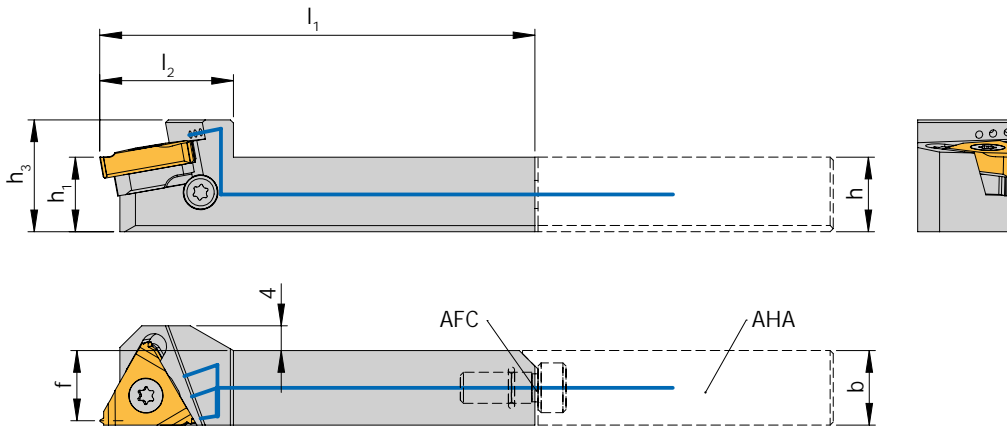

Rechte Ausführung abgebildet
 Right-hand execution shown
 Versione destra in figura

AFC = Schnittstelle
 AFC = Interface
 AFC = Interfaccia
 AHA = Anschlag
 AHA = fix stop
 AHA = Fermo



Trägerwerkzeuge / Holders / Utensili

Bezeichnung Designation Articolo	$h = h_1 = b$	h_3	l_1	l_2	f	Schneideinsatz Insert Inserto
AL 12-3R-IK-AFC	12	18	70	21,5	11,3	16ER...
AL 16-3R-IK-AFC N	16	22	70	21,5	15,3	16ER...



Hinweis: Passende Anschläge finden Sie auf Seite 86 – 89

Remark: For matching fix stops see page 86 – 89

Nota: I fermi compatibili si trovano a pagina 86 – 89

Ersatzteile / Spare Parts / Ricambi

Trägerwerkzeug Holder Utensile	Schraube Screw Vite	Schraube + Scheibe für Unterlegplatte Screw + washer for support pad Vite + bussola per supporto	Schlüssel Key Chiave	Unterlegplatte R Support pad R Supporto R	O-Ring O-ring O-ring
AL 12-3R-IK-AFC	SA3T	SY3T	KS 2510	YE3	OR 4,7X1 FKM80 SCHWARZ
AL 16-3R-IK-AFC	SA3T	SY3T	KS 2510	YE3	OR 4,7X1,6 NBR70

Holders with screw clamping
 Steli con fissaggio a vite

SLAO L/R ...-IK-AFC

mit Innenkühlung / with through tool coolant / con adduzione interna del refrigerante

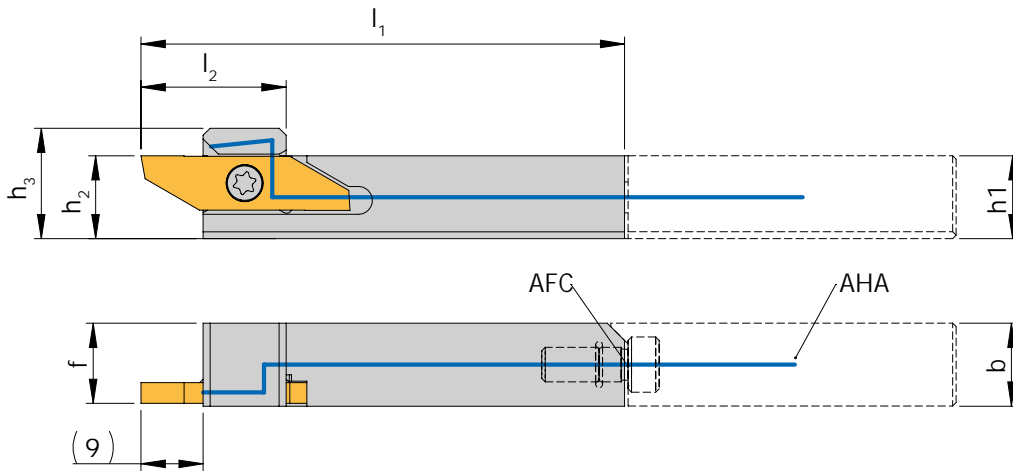

Rechte Ausführung abgebildet
 Right-hand execution shown
 Versione destra in figura

AFC = Schnittstelle
 AFC = interface
 AFC = Interfaccia
 AHA = Anschlag
 AHA = fix stop
 AHA = Fermo



Trägerwerkzeuge / Holders / Utensili

Bezeichnung Designation Articolo	h1 / h2	h3	b	l ₁	l ₂	f	Schneideinsatz Insert Inserto
SLAOL/R 1212 E08-IK-AFC	12	16	12	70	21	11,6	L.. 08...
SLAOL/R 1616 E08-IK-AFC N	16	20	16	70	21	15,6	L.. 08...



Hinweis: Passende Anschläge finden Sie auf Seite 86 – 89
 Remark: For matching fix stops see page 86 – 89
 Nota: I fermi compatibili si trovano a pagina 86 – 89

Ersatzteile / Spare Parts / Ricambi

Trägerwerkzeug Holder Utensile	Schraube Screw Vite	Schlüssel Key Chiave	O-Ring O-ring O-ring
SLAOL/R 1212 E08-IK-AFC	AS 0028	KS 1111	OR 4,7X1 FKM80 SCHWARZ
SLAOL/R 1616 E08-IK-AFC	AS 0028	KS 1111	OR 4,7X1,6 NBR70

Holders with screw clamping
 Steli con fissaggio a vite

SLAO L/R ...-AFC

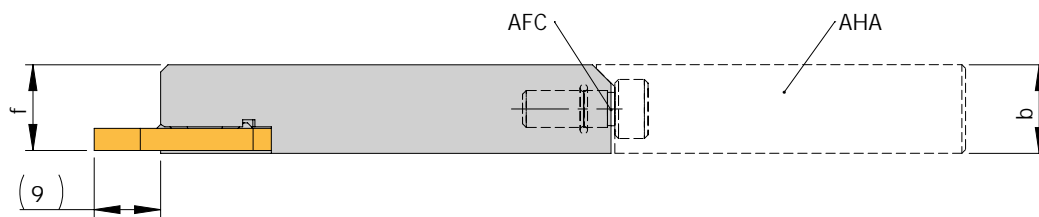
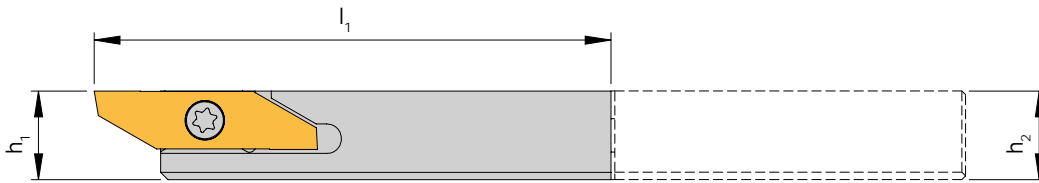
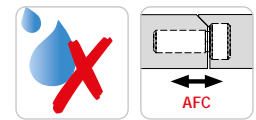

Rechte Ausführung abgebildet
 Right-hand execution shown
 Versione destra in figura

AFC = Schnittstelle
 AFC = interface
 AFC = interfaccia
 AHA = Anschlag
 AHA = fix stop
 AHA = Fermo

Trägerwerkzeuge / Holders / Utensili

Bezeichnung Designation Articolo	h1 / h2	b	l ₁	f	Schneideinsatz Insert Inserto
SLAOL/R 1212 E08-AFC	12	12	70	11,6	L.. 08...



Hinweis: Passende Anschläge finden Sie auf Seite 86 – 89
 Remark: For matching fix stops see page 86 – 89
 Nota: I fermi compatibili si trovano a pagina 86 – 89

Ersatzteile / Spare Parts / Ricambi

Trägerwerkzeug Holder Utensile	Schraube Screw Vite	Schlüssel Key Chiave	O-Ring O-ring O-ring
SLAOL/R 1212 E08-AFC	AS 0028	KS 1111	OR 4,7X1 FKM80 SCHWARZ

Holders with screw clamping
 Steli con fissaggio a vite

SLXO L ...-IK-AFC

mit Innenkühlung / with through tool coolant / con adduzione interna del refrigerante

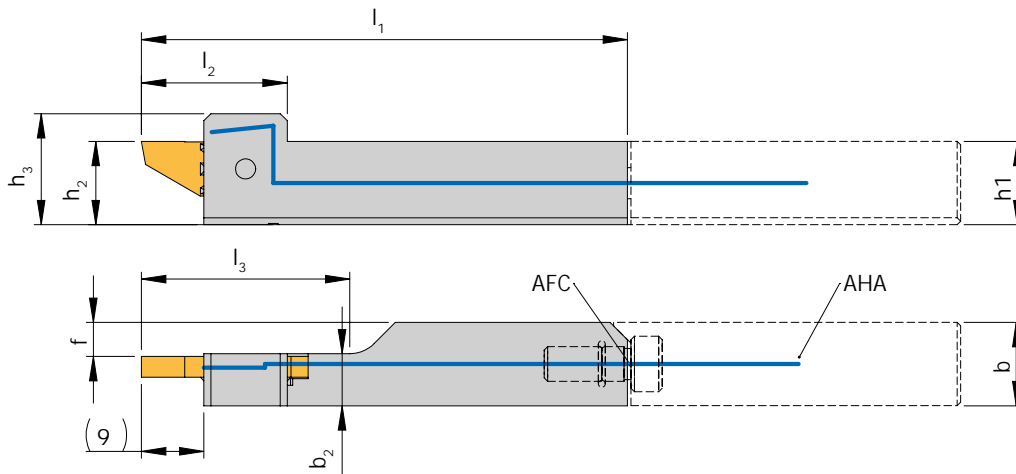

Rechte Ausführung abgebildet
 Right-hand execution shown
 Versione destra in figura

AFC = Schnittstelle
 AFC = interface
 AFC = Interfaccia
 AHA = Anschlag
 AHA = fix stop
 AHA = Fermo



Trägerwerkzeuge / Holders / Utensili

Bezeichnung Designation Articolo	h1 / h2	h3	b	b ₂	l ₁	l ₂	l ₃	f	Schneideinsatz Insert Inserto
SLXOL 1212 E08-IK-AFC	12	16	12	7,5	70	21	30	11,6	L.. 08...
SLXOL 1616 E08-IK-AFC N	16	20	16	7,5	70	21	30	8,9	L.. 08...



Hinweis: Passende Anschläge finden Sie auf Seite 86 – 89
 Remark: For matching fix stops see page 86 – 89
 Nota: I fermi compatibili si trovano a pagina 86 – 89

Ersatzteile / Spare Parts / Ricambi

Trägerwerkzeug Holder Utensile	Schraube Screw Vite	Schlüssel Key Chiave	O-Ring O-ring O-ring
SLXOL 1212 E08-IK-AFC	AS 0028	KS 1111	OR 4,7X1 FKM80 SCHWARZ
SLXOL 1616 E08-IK-AFC	AS 0029	KS 1111	OR 4,7X1,6 NBR70

Holders with screw clamping
 Steli con fissaggio a vite

SLXO L ...-AFC

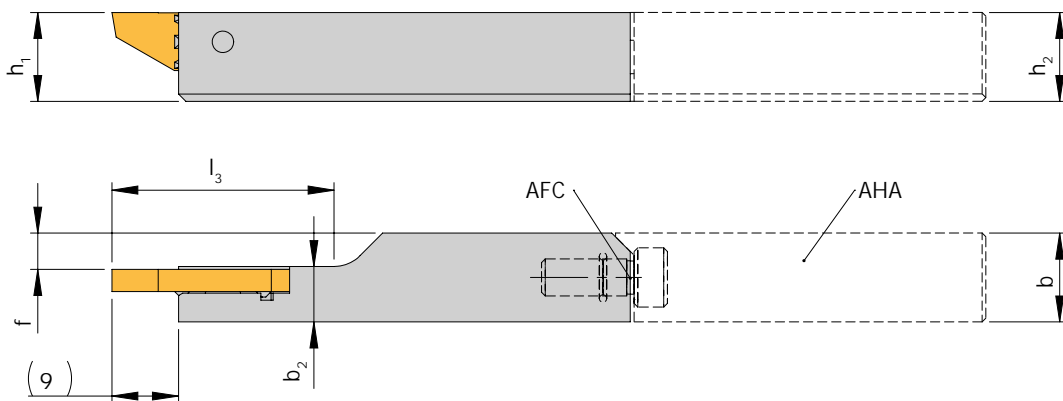
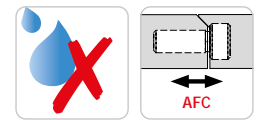

Linke Ausführung abgebildet
 Left-hand execution shown
 Versione sinistra in figura
 AFC = Schnittstelle
 AFC = interface
 AFC = Interfaccia
 AHA = Anschlag
 AHA = fix stop
 AHA = Fermo

Trägerwerkzeuge / Holders / Utensili

Bezeichnung Designation Articolo	h1 / h2	b	b ₂	l ₁	l ₃	f	Schneideinsatz Insert Inserto
SLXOL 1212 E08-AFC	12	12	7,5	70	30	4,9	L.. 08...



Hinweis: Passende Anschläge finden Sie auf Seite 86 – 89
 Remark: For matching fix stops see page 86 – 89
 Nota: I fermi compatibili si trovano a pagina 86 – 89

Ersatzteile / Spare Parts / Ricambi

Trägerwerkzeug Holder Utensile	Schraube Screw Vite	Schlüssel Key Chiave	O-Ring O-ring O-ring
SLXOL 1212 E08-AFC	AS 0028	KS 1111	OR 4,7X1 FKM80 SCHWARZ

Holders with screw clamping
 Steli con fissaggio a vite

SLXO R ...-IK-AFC

mit Innenkühlung / with through tool coolant / con adduzione interna del refrigerante

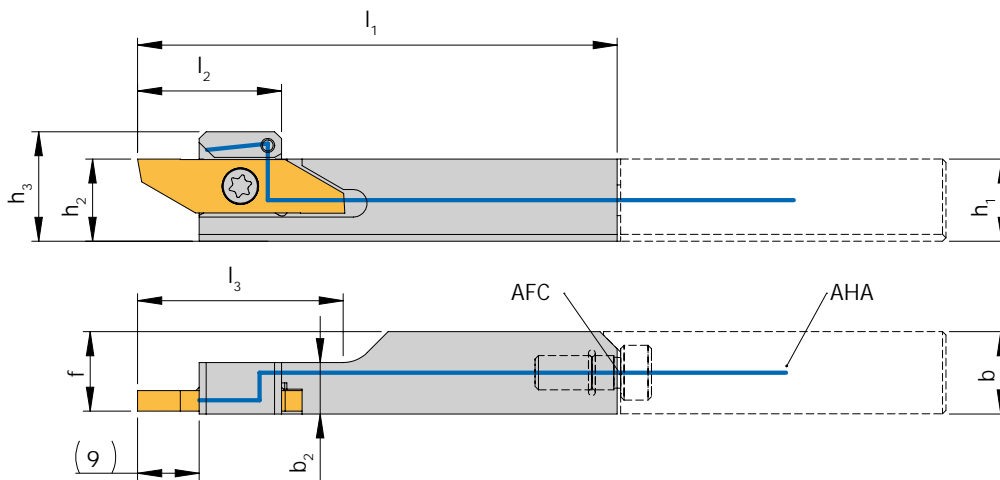

Rechte Ausführung abgebildet
 Right-hand execution shown
 Versione destra in figura

AFC = Schnittstelle
 AFC = interface
 AFC = Interfaccia
 AHA = Anschlag
 AHA = fix stop
 AHA = Fermo



Trägerwerkzeuge / Holders / Utensili

Bezeichnung Designation Articolo	h1 / h2	h3	b	b ₂	l ₁	l ₂	l ₃	f	Schneideinsatz Insert Inserto
SLXOR 1212 E08-IK-AFC	12	16	12	7,5	70	21	30	11,6	L.. 08...
SLXOR 1616 E08-IK-AFC N	16	20	16	7,5	70	21	30	15,6	L.. 08...



Hinweis: Passende Anschläge finden Sie auf Seite 86 – 89

Remark: For matching fix stops see page 86 – 89

Nota: I fermi compatibili si trovano a pagina 86 – 89

Ersatzteile / Spare Parts / Ricambi

Trägerwerkzeug Holder Utensile	Schraube Screw Vite	Schlüssel Key Chiave	O-Ring O-ring O-ring
SLXOR 1212 E08-IK-AFC	AS 0029	KS 1111	OR 4,7X1 FKM80 SCHWARZ
SLXOR 1616 E08-IK-AFC	AS 0029	KS 1111	OR 4,7X1,6 NBR70

Holders with screw clamping
 Steli con fissaggio a vite

SLXO R ...-AFC

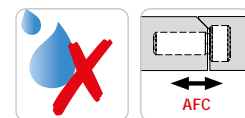
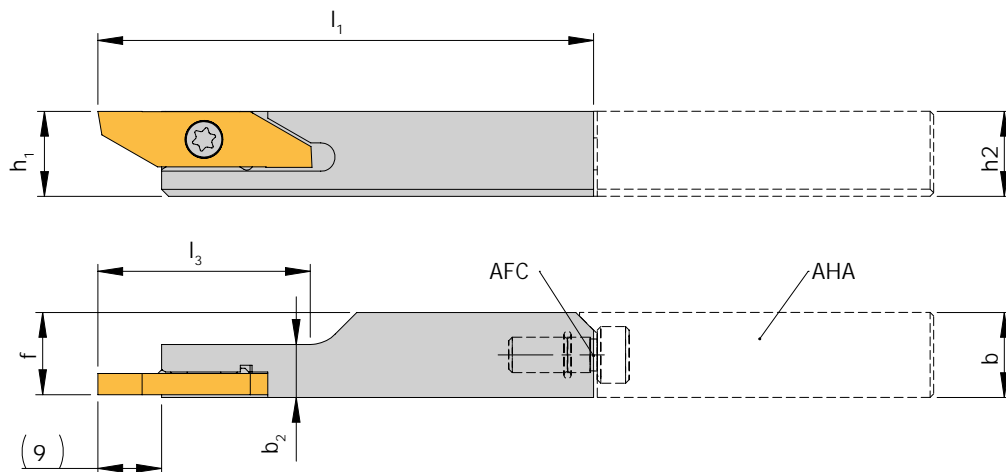

Rechte Ausführung abgebildet
 Right-hand execution shown
 Versione destra in figura
AFC = Schnittstelle
 AFC = interface
 AFC = Interfaccia
AHA = Anschlag
 AHA = fix stop
 AHA = Fermo

Trägerwerkzeuge / Holders / Utensili

Bezeichnung Designation Articolo	h1 / h2	b	b ₂	l ₁	l ₃	f	Schneideinsatz Insert Inserto
SLXOR 1212 E08-AFC	12	12	7,5	70	30	11,6	L.. 08...



Hinweis: Passende Anschläge finden Sie auf Seite 86 - 89
 Remark: For matching fix stops see page 86 - 89
 Nota: I fermi compatibili si trovano a pagina 86 - 89

Ersatzteile / Spare Parts / Ricambi

Trägerwerkzeug Holder Utensile	Schraube Screw Vite	Schlüssel Key Chiave	O-Ring O-ring O-ring
SLXOR 1212 E08-AFC	AS 0028	KS 1111	OR 4,7X1 FKM80 SCHWARZ

AHA...-UN...-AFC

Achtung: Dieser Anschlag ist nur für ARNO-Werkzeughalter (AWL-...) mit UN-Übergabe ausgelegt. / Attention: This fix stop is only for ARNO tool holders (AWL -...) designed with UN delivery. / **Attenzione: questo fermo è solo per i portautensili ARNO (AWL -...) progettato con connessione refrigerante UN.**

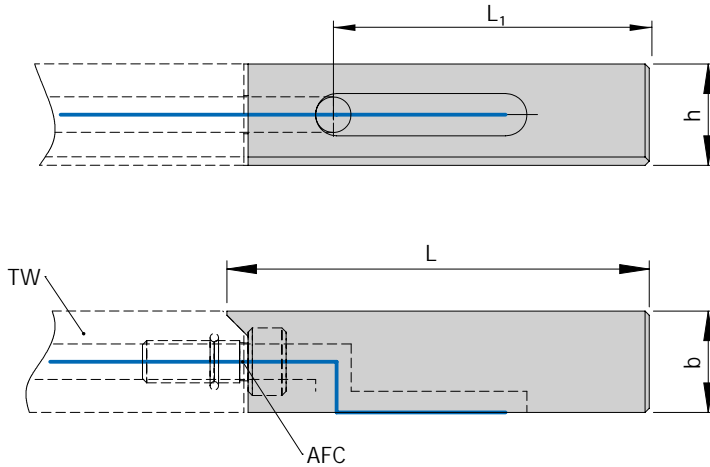

TW = Trägerwerkzeuge
 TW = Holders
 TW = Utensili
 AFC = Schnittstelle
 AFC = interface
 AFC = Interfaccia
 AHA = Anschlag
 AHA = fix stop
 AHA = Fermo

N NEU/NEW/
 NUOVO

Trägerwerkzeuge / Holders / Utensili

Bezeichnung Designation Articolo	L	L ₁	h	b
AHA 1212-UN-27-50-AFC ²⁾	50	27	12	12
AHA 1212-UN-37-50-AFC	50	37	12	12
AHA 1212-UN1-37-50-AFC ¹⁾	50	37	12	12
AHA 1616-UN-20-50-AFC N	50	20	16	16
AHA 1616-UN-27-50-AFC N	50	27	16	16
AHA 1616-UN-37-50-AFC N	50	37	16	16

1) Anschlag mit Kühlmittelübergabenut auf der anderen Seite - Geeignet um den AFC-Klemmhalter Überkopf zu montieren.
 Fixed stop with coolant transfer groove on the opposite side - To mount the AFC tool holder overhead.
 Elemento di fermo con scanalatura per il passaggio del liquido refrigerante sull'altro lato - Adatto per il montaggio invertito dell'adattatore AFC.

2) Anschlag mit versetzter Kühlmittelübergabenut - Geeignet um den AFC-Klemmhalter weiter ausspannen zu können.
 Fixed stop with offset coolant transfer groove - To extend the AFC tool holder overhang.
 Elemento di fermo con scanalatura sfalsata per il passaggio del liquido refrigerante - Adatto per poter serrare l'adattatore AFC.

Hinweis: Passende Trägerwerkzeuge finden Sie auf Seite 58 – 85
 Remark: For matching tool holders see page 58 – 85
 Nota: Gli utensili compatibili si trovano a pagina 58 – 85

Ersatzteile / Spare Parts / Ricambi

Trägerwerkzeug Holder Utensile	AFC-Stift AFC Pin Pin AFC	Schlüssel Key Chiave
AHA 1212-UN...-AFC	458101	S-AFC-HSK25
AHA 1616-UN...-AFC	458101	S-AFC-HSK25

AHA...-AFC

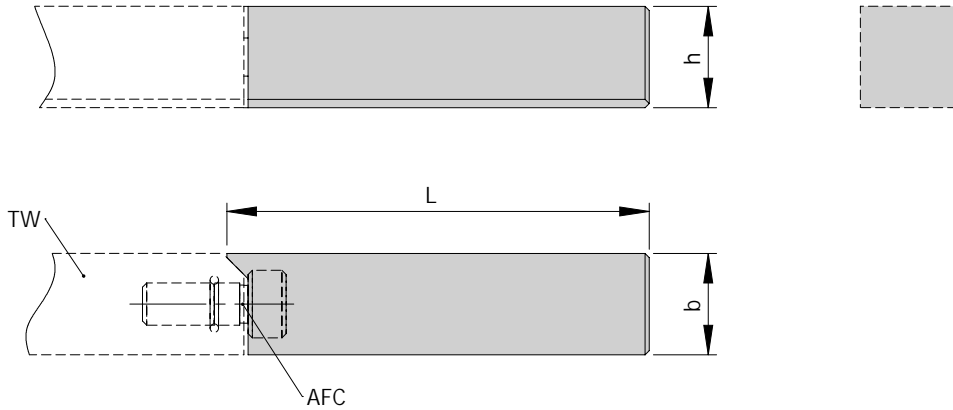
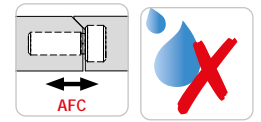

TW = Trägerwerkzeuge
TW = Holders
TW = Utensili

AFC = AFC-Schnittstelle
AFC = AFC interface
AFC = Interfaccia AFC

Anschlag / Fix stop / Fermo

Bezeichnung Designation Articolo	L	h	b
AHA 1212-50-AFC	50	12	12



Hinweis: Passende Trägerwerkzeuge finden Sie auf Seite 58 – 85
Remark: For matching tool holders see page 58 – 85
Nota: Gli utensili compatibili si trovano a pagina 58 – 85

Ersatzteile / Spare Parts / Ricambi

Trägerwerkzeug Holder Utensile	AFC-Stift AFC Pin Pin AFC	Schlüssel Key Chiave
AHA 1212-50-AFC	458101	S-AFC-HSK25

Anschlag zum Verschließen der Kühlung - AFC-System

Fixed stop for closing off the coolant circuit in the AFC system

Elemento di fermo per la chiusura del raffreddamento - Sistema AFC

KV...-AFC

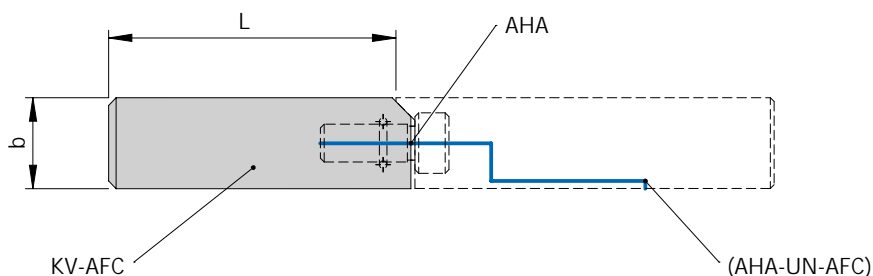
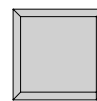
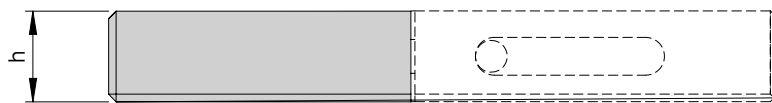

AFC = Schnittstelle
AFC = interface
AFC = Interfaccia

AHA = Anschlag
AHA = fix stop
AHA = Fermo



Trägerwerkzeuge / Holders / Utensili

Bezeichnung Designation Articolo	l	h	b
KV-1212-AFC	38	12	12
KV-1616-AFC N	38	16	16

! Bei Auskräglängen > 28mm verwenden Sie bitte den Anschlag AHA 1212-UN-27-50-AFC

Ersatzteile / Spare Parts / Ricambi

Trägerwerkzeug Holder Utensile	O-Ring O-ring O-ring
KV-1212-AFC	OR 4,7X1 FKM80 SCHWARZ
KV-1616-AFC	OR 4,7X1,6 NBR70

Unterlagplatte - AFC-System

Support pad - AFC system

Supporto - Sistema AFC

UP...-AFC

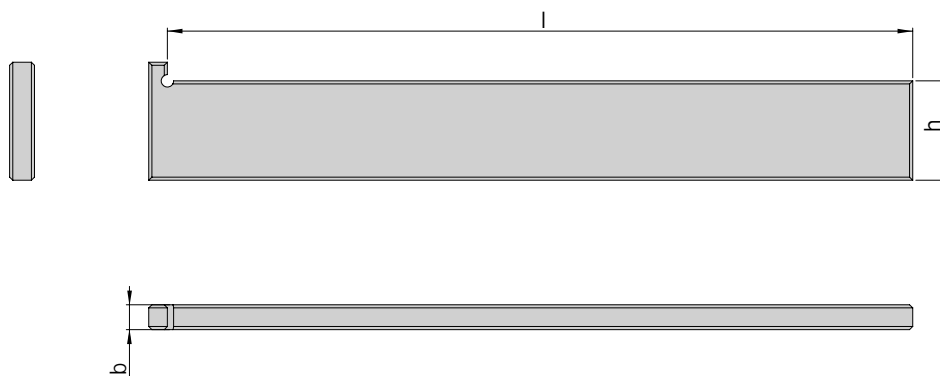

N NEU/NEW/
NUOVO

Unterlagplatte / Support pad / Supporto

Bezeichnung Designation Articolo	l	h	b
UP-1212-AFC	115	12	4
UP-1616-AFC-104 N	104	16	4
UP-1616-AFC-120 N	120	16	4
UP-1616-AFC-132 N	132	16	4

COOL VON ANFANG AN.

AWL-Linearschlitten* : mit integrierter Kühlmittelzufuhr – angemeldet zum Patent.

Praktisch für eine sichere und effiziente Kühlung: Durch die integrierte Kühlmittelzufuhr des AWL-Linearschlittens gehören aufwendige Installationen von Kühlmittelschläuchen sowie platzraubende Aufbauten der Vergangenheit an. Dank zwei getrennter Kühlkanäle können Sie die Zufuhr jederzeit komplett oder teilweise abstellen – auch bei 130 bar bleibt alles absolut dicht.

Auch clever: Die Kontermuttern an den Schrauben der Spannpratzen heben die Keile beim Aufdrehen an. So kann der Träger einfach herausgezogen werden und der Werkzeugwechsel gelingt spielend leicht. Die seitliche Anbringung der Spannpratzen sorgt im Betrieb außerdem für ein ausgezeichnetes Spannverhalten und eine niedrige Aufbauhöhe von nur 5,5 mm.

* AWL-Linearschlitten sind aktuell für ausgewählte Maschinen verfügbar. Auf Anfrage fertigen wir gerne AWL-Schlitten passend zu Ihrem Maschinentyp an. Senden Sie Ihre Anfrage einfach an: anfrage@arno.de



INTEGRIERTE VORTEILE des AFC-Linearschlittens

Sicher kühlen, ohne Schlauchaufbauten – dank der integrierten Kühlmittelzufuhr im Linearschlitten

Flexibel – die Kühlmittelzufuhr kann komplett oder teilweise abgeklemmt werden

Sicher gespannt, einfach gelöst – seitliche Spannpratzen sorgen für ein gutes Spannverhalten, Kontermuttern in den Schrauben erleichtern den Wechsel

Flexibel kombinierbar

- Alle ein- und zweiteiligen Trägerwerkzeuge in entsprechenden Größen einsetzbar

Nur 5,5 mm Aufbauhöhe

- Optimal bei beengtem Platzverhältnis der Langdrehmaschinen



ARNO DIGITAL // Entdecken Sie die Vorteile des AWL-Linearschlittens auch auf langdrehen.arno.de

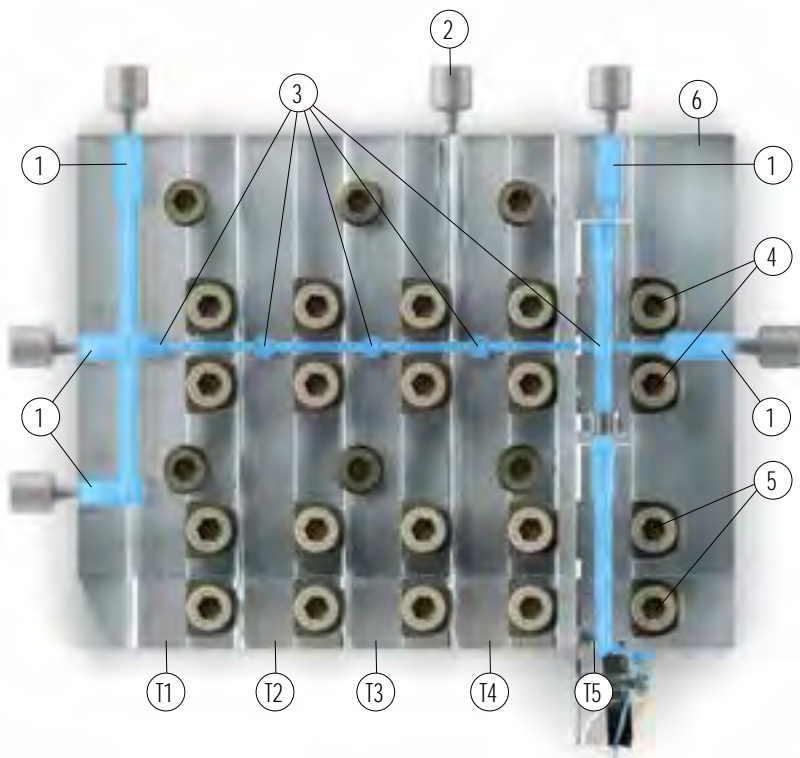

5 Kühlmittelzugänge

- Für jeden Maschinentyp passend
- Präzise Kühlmittelführung

2 seitliche Spannpratzen

- Passend für ein- und zweiteilige Haltersysteme
- Stabil durch perfektes Spannverhalten
- Keile heben sich beim Öffnen der Schrauben dank Kontermuttern automatisch an

Werkzeuge mit und ohne Innenkühlung gleichzeitig einsetzbar

- Kühlmittelzufuhr komplett oder teilweise über Sperrventil abklemmbar
- Absolut dicht

- T Kammern T1, T2, T3, T4 für 12 x 12 mm Trägerwerkzeuge und T5 für 16 x 16 mm Trägerwerkzeug oder 12 x 12 mm Trägerwerkzeug mit 4 mm Ausgleichsblock
1. 5 Anschlussmöglichkeiten zur Kühlmittelversorgung
 2. Sperrgewindestift zur Aufteilung der Kühlmittelversorgung T1, T2 und T3, T4, T5 innerhalb des Werkzeughalters
 3. Gewindestifte zum Verschließen/Öffnen der einzelnen Kammern
 4. 2 Spannkeile zur Montage der Anschläge AHA
 5. 2 Spannkeile zur Montage der Trägerwerkzeuge
 6. Abstechstahlbruchererkennung

COOL RIGHT FROM THE START.

AWL sliding head*: with integrated coolant feed – patent applied.

Practical to achieve reliable efficient cooling: the integrated coolant feed on the AWL sliding head relegates complex installations with coolant hoses and space-consuming set-ups to the past. Thanks to two separate coolant holes, you can cut off coolant feed completely or partially at any time – even at 130 bar everything stays absolutely leak-proof.

Another clever feature: the lock nuts on the clamping claw screws raise the wedges when turned. This makes it easier to remove the holder to facilitate tool changes. The clamping claws mounted on the side also enhance the clamping force and permit a low height of only 5.5 mm.

* AWL sliding heads are currently available for selected machines. On request we manufacture AWL heads to fit your machine type. Simply send your enquiry to anfrage@arno.de



INTEGRATED ADVANTAGES of the AFC sliding head

Reliable cooling without hose assemblies – thanks to the integrated coolant feed in the sliding head

Flexible – the coolant feed can be completely or partially cut off

Securely clamped, easy to release – side-mounted clamping claws provide excellent clamping, lock nuts in the screws make tool changing easy

Flexibly combinable

- All one and two-part tool holders are available in various sizes

Height of only 5.5 mm

- Ideal for restricted spaces inside Swiss type machines



ARNO DIGITAL // Discover the benefits of the AWL sliding head at langdrehen.arno.de

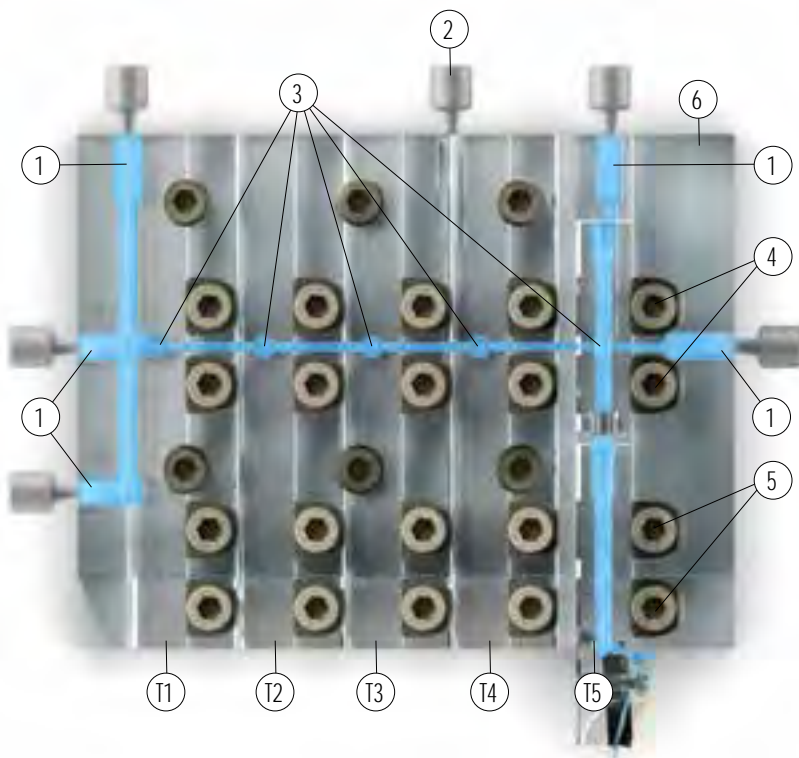

T Chambers T1, T2, T3, T4 for 12 x 12 mm tool holders and T5 for 16 x 16 mm tool holder or 12 x 12 mm tool holder with 4 mm compensator block

1. 5 connection options for coolant supply
2. Locking threaded pin to separate coolant supply T1, T2 and T3, T4, T5 inside tool holder
3. Threaded pins to close/open individual chambers
4. 2 clamping wedges to fit the AHA fixed stops
5. 2 clamping wedges to fit the tool holders
6. Parting insert rupture detection

5 coolant holes

- The right size for any machine type
- Precise coolant feed

2 side clamping claws

- Fits one or two-part holder systems
- Rigid thanks to perfect clamping
- Wedges lift automatically when screws are opened thanks to lock nuts

Tools with and without internal cooling can be used simultaneously

- Coolant feed can be cut off completely or partially by shut-off valve
- Absolutely leak-proof

COOL FIN DALL'INIZIO.

Pattino lineare AWL*: con alimentazione integrata del refrigerante - in attesa di brevetto.

Pratico per un raffreddamento sicuro ed efficace: Grazie all'alimentazione integrata del refrigerante del pattino lineare AWL l'installazione di costosi tubi flessibili e strutture che occupano spazio sono ormai un ricordo del passato. Grazie a due canali di raffreddamento separati è possibile interrompere l'alimentazione, completamente o in parte, anche ad una pressione di 130 bar tutto resta assolutamente ermetico.

Anche intelligente: i dadi di bloccaggio sulle viti delle staffe di serraggio sollevano i cunei durante l'allentamento. In questo modo il supporto può essere estratto semplicemente e il cambio utensile è estremamente semplice. Il montaggio laterale delle staffe di bloccaggio garantisce inoltre un eccellente comportamento di bloccaggio durante il funzionamento e un'altezza di montaggio ridotta di soli 5,5 mm.

* I pattini lineari AWL sono disponibili attualmente per un numero selezionato di macchine.
Su richiesta realizziamo volentieri pattini AWL adatti al vostro tipo di macchina. Inviare semplicemente la vostra richiesta a: anfrage@arno.de



VANTAGGI INTEGRATI del pattino lineare AFC

Raffreddamento sicuro, senza tubi flessibili - grazie al sistema di alimentazione del refrigerante integrato nel pattino lineare

Flessibile - l'alimentazione di refrigerante può essere bloccata completamente o in parte

Serraggio sicuro, sbloccaggio semplice - le staffe di bloccaggio laterali garantiscono un ottimo comportamento al serraggio, i dadi di bloccaggio sulle viti facilitano il cambio utensile

Combinabile in maniera flessibile

- Tutti gli utensili in uno o due pezzi possono essere utilizzati nelle dimensioni corrispondenti

Altezza di montaggio di soli 5,5 mm

- Ottimale quando lo spazio sui torni a fantina mobile è ristretto



ARNO DIGITAL // Scoprite i vantaggi del pattino lineare AWL anche per la tornitura cilindrica su langdrehen.arno.de

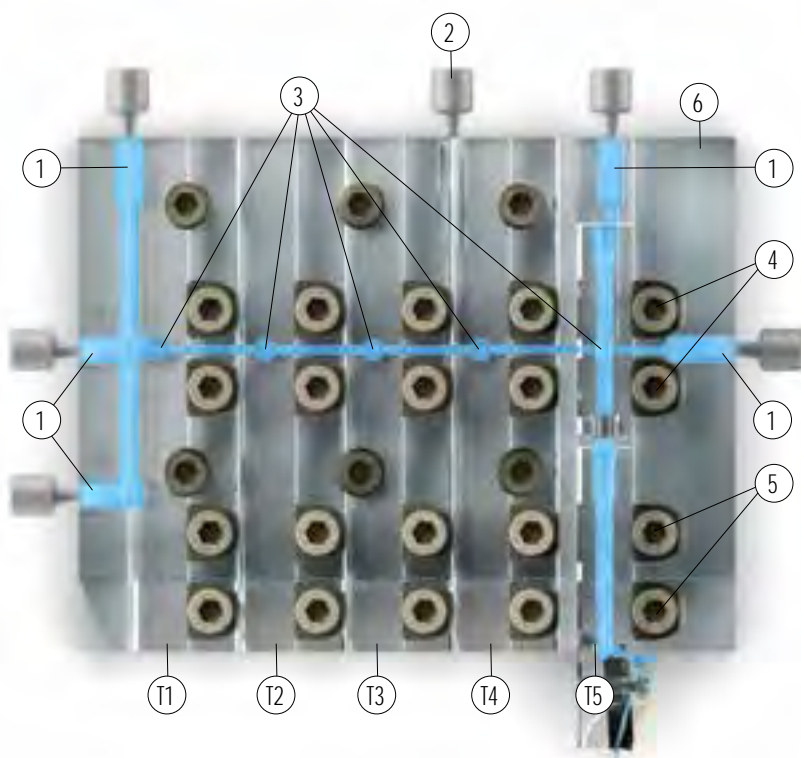

5 ingressi per il refrigerante

- Adatto per ogni tipo di macchina
- Alimentazione precisa del refrigerante

2 staffe di bloccaggio laterali

- Adatto a sistemi di supporto ad un pezzo o a due pezzi
- Stabile grazie a un perfetto comportamento al serraggio
- I cunei si sollevano automaticamente quando vengono allentate le viti grazie ai dadi di bloccaggio

Possono essere utilizzati utensili con e senza raffreddamento interno contemporaneamente

- L'adduzione di refrigerante può essere bloccata completamente o in parte tramite un valvola di blocco
- Tenuta assoluta

- T Camere T1, T2, T3, T4 per utensili da 12 x 12 mm e T5 per utensili da 16 x 16 mm o utensili da 12 x 12 mm con blocco di compensazione 4 mm
1. 5 Raccordi per l'alimentazione del liquido refrigerante
 2. Spina filettata di arresto per suddividere l'alimentazione del refrigerante tra T1, T2 e T3, T4, T5 all'interno del portautensile
 3. Viti senza testa per la chiusura/apertura delle singole camere
 4. 2 Cunei d'arresto per il montaggio dei fermi AHA
 5. 2 Cunei d'arresto per il montaggio degli utensili
 6. Rilevamento rottura inserito da troncatura

ARNO Werkzeughalter Langdrehen – mit Innenkühlung / ARNO tool holders for sliding head lathes – with internal cooling / Porta-utensili ARNO per la tornitura cilindrica - con raffreddamento interno

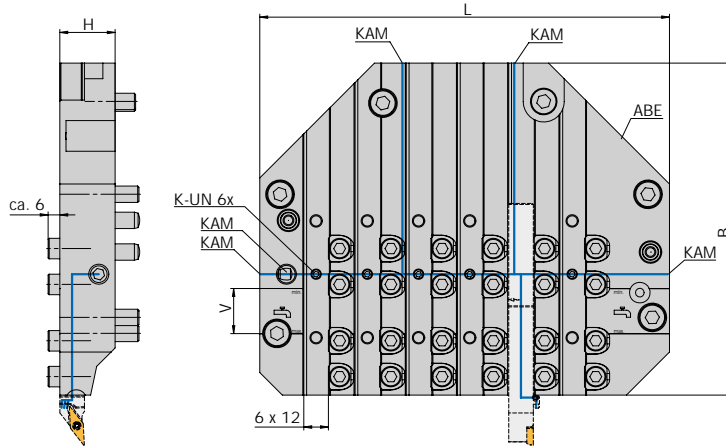

KAM = Kühlmittelanschlussmöglichkeiten

KAM = coolant adapter options

KAM = raccordi del refrigerante

V = In diesem Bereich ist die Kühlung über UN sichergestellt
V = coolant supply is ensured via UN in this range

V = In quest'area l'alimentazione del refrigerante è tramite connessione UN

ABE = Abstechstahlbrucherennung, Original von Citizen kann montiert werden

ABE = parting insert rupture detection, Citizen original can be fitted

ABE = Rilevamento rottura inserto da troncatrice, può essere montato ricambio originale Citizen

Trägerwerkzeuge / Holders / Utensili

Bezeichnung Designation Articolo	L	B	H	12 x 12	V	KAM
AWL-BTF1012-1K	200	162	27	6x	22	G1/8" (5x)

ARNO® SpecialDesign

Hinweis: Auf Anfrage fertigen wir gerne AWL-Schlitten passend zu Ihrem Maschinentyp an.

On request we manufacture AWL heads to fit your machine type.

Su richiesta realizziamo piastre AWL adatti al vostro tipo di macchina.

Ersatzteile / Spare Parts / Ricambi

Trägerwerkzeug Holder Utensile	Spannkeil Clamping wedge Cuneo di bloccaggio	Blindstopfen Dummy plug Tappi ciechi	Verschluss- schraube Screw plug Vite forniti	Zylinderstift Dowel pin Perno di centraggio	Kühlmittel- anschluss-winklig, fest Coolant connection, angled, fixed Raccordo angolare del refrigerante, fisso	Drehmomentquer- griff Torque wrench T-handle Chiave dinamometri- ca con impugnatura a T	Sechskantklinge Hexagonal blade Lama esagonale
AWL-BTF1012-1K	AWL-SK111345	GN749-G1/8-A	AS 0075	ISO 8735-8x24-A	KA 005	T53	T53SW5

! Eine spätere Demontage der Verschlusschraube ist nicht mehr möglich.
Once the screw plug is tightened it can not be removed anymore.
Una volta serrata la vite non sarà più possibile rimuoverla

! Hinweis: Passende Anschläge finden Sie auf Seite 86 – 89
Remark: For matching fix stops see page 86 – 89
Nota: I fermi compatibili si trovano a pagina 86 – 89

! Hinweis: Passende Trägerwerkzeuge finden Sie auf Seite 58 – 85
Remark: For matching tool holders see page 58 – 85
Nota: Gli utensili compatibili si trovano a pagina 58 – 85

ARNO Werkzeughalter Langdrehen – mit Innenkühlung / ARNO tool holders for sliding head lathes – with internal cooling / Porta-utensili ARNO per la tornitura cilindrica - con raffreddamento interno

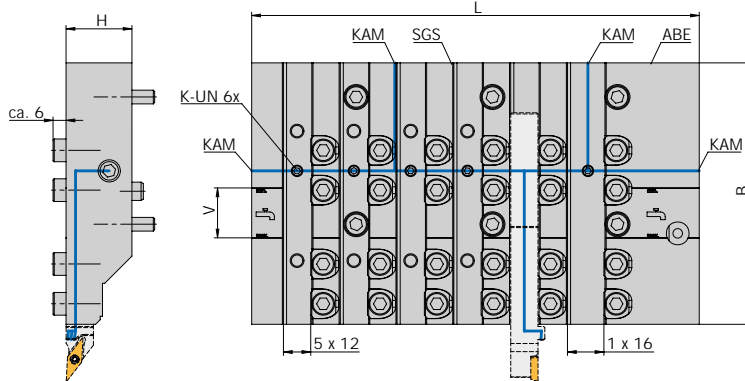

KAM = Kühlmittelanschlussmöglichkeiten
KAM = coolant adapter options
KAM = raccordi del refrigerante

SGS = Sperrgewindestift - bei Bedarf für zwei sperate Druckkammern (Hochdruck)
SGS = locking threaded pin - for two separate pressure chambers (high pressure)
SGS = spina filettata di chiusura - se necessario genera due camere con pressioni separate (alta pressione)

V = In diesem Bereich ist die Kühlmittelversorgung über UN sichergestellt
V = coolant supply is ensured via UN in this range
V = In quest'area l'alimentazione del refrigerante è tramite connessione UN

ABE = Abstechstahlbruchererkennung, Original von Citizen kann montiert werden
ABE = parting insert rupture detection, Citizen original can be fitted
ABE = Rilevamento rottura inserito da troncatura, può essere montato ricambio originale Citizen

Trägerwerkzeuge / Holders / Utensili

Bezeichnung Designation Articolo	L	B	H	12 x 12	16 x 16	V	KAM
AWL-BTF2212-1K	197	115	29	5x	1x	22	G1/8" (4x)

ARNO® SpecialDesign

Hinweis: Auf Anfrage fertigen wir gerne AWL-Schlitten passend zu Ihrem Maschinentyp an.
On request we manufacture AWL heads to fit your machine type.
Su richiesta realizziamo piastre AWL adatti al vostro tipo di macchina.

Ersatzteile / Spare Parts / Ricambi

Trägerwerkzeug Holder Utensile	Spannkeil Clamping wedge Cuneo di bloccaggio	Blindstopfen Dummy plug Tappi ciechi	Verschluss- schraube Screw plug Vite forniti	Sperrgewindestift Locking threaded pin Vite senza testa di arresto	Unterlagplatte Support pad Supporto	Drehmomentquer- griff Torque wrench T-handle Chiave dinamo- metrica con impugnatura a T	Sechskantklinge Hexagonal blade Lama esagonale
AWL-BTF2212-1K	AWL-SK111345	GN749-G1/8-A	AS 0075	AWL-SGSM1045	UP-1212-AFC	T53	T53SW5

! Eine spätere Demontage der Verschlusschraube ist nicht mehr möglich.
Once the screw plug is tightened it can not be removed anymore.
Una volta serrata la vite non sarà più possibile rimuoverla

! Hinweis: Passende Anschläge finden Sie auf Seite 86 – 89
Remark: For matching fix stops see page 86 – 89
Nota: I fermi compatibili si trovano a pagina 86 – 89

Unterlagplatte UP-1212-AFC: Mit dieser Unterlagplatte kann statt einem 16x16 Klemmhalter auch ein 12x12 Klemmhalter gespannt werden.
Shim UP-1212-AFC: This shim permits the clamping of a 12x12 holder instead of a 16x16 holder.
Piastra di supporto UP-1212-AFC: Con questa piastra è possibile serrare invece di un adattatore 16x16 un adattatore 12x12.

! Hinweis: Passende Trägerwerkzeuge finden Sie auf Seite 58 – 85
Remark: For matching tool holders see page 58 – 85
Nota: Gli utensili compatibili si trovano a pagina 58 – 85

ARNO Werkzeughalter Langdrehen – mit Innenkühlung / ARNO tool holders for sliding head lathes – with internal cooling / Porta-utensili ARNO per la tornitura cilindrica - con raffreddamento interno

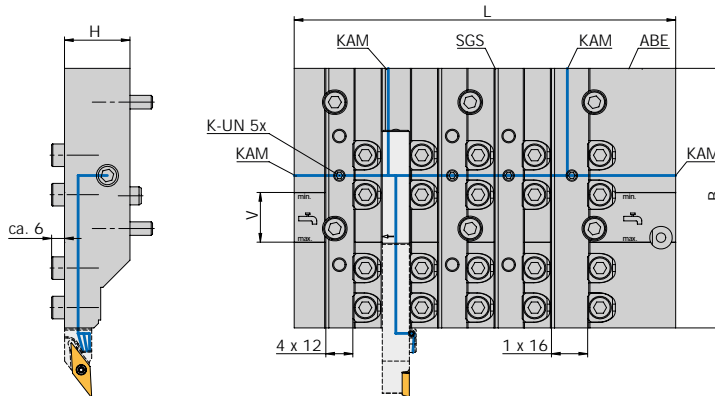

KAM = Kühlmittelanschlussmöglichkeiten

KAM = coolant adapter options

KAM = raccordi del refrigerante

SGS = Sperrgewindestift - bei Bedarf für zwei sperate Druckkammern (Hochdruck)

SGS = locking threaded pin - for two separate pressure chambers (high pressure)

SGS = spina filettata di chiusura - se necessario genera due camere con pressioni separate (alta pressione)

V = In diesem Bereich ist die Kühlmittelversorgung über UN sichergestellt

V = coolant supply is ensured via UN in this range

V = In quest'area l'alimentazione del refrigerante è tramite connessione UN

ABE = Abstechstahlbruchererkennung, Original von Citizen kann montiert werden

ABE = parting insert rupture detection, Citizen original can be fitted

ABE = Rilevamento rottura inserto da troncatore, può essere montato ricambio originale Citizen

Trägerwerkzeuge / Holders / Utensili

Bezeichnung Designation Articolo	L	B	H	12 x 12	16 x 16	V	KAM
AWL-BTF2412-IK	169	115	29	4x	1x	22	G1/8" (4x)

ARNO® SpecialDesign

Hinweis: Auf Anfrage fertigen wir gerne AWL-Schlitten passend zu Ihrem Maschinentyp an.

On request we manufacture AWL heads to fit your machine type.

Su richiesta realizziamo piastre AWL adatti al vostro tipo di macchina.

Ersatzteile / Spare Parts / Ricambi

Trägerwerkzeug Holder Utensile	Spannkeil Clamping wedge Cuneo di bloccaggio	Blindstopfen Dummy plug Tappi ciechi	Verschluss-schraube Screw plug Vite forniti	Sperrgewindestift Locking threaded pin Vite senza testa di arresto	Unterlagplatte Support pad Supporto	Drehmomentquergriff Torque wrench T-handle Chiave dinamometrica con impugnatura a T	Sechskantklinge Hexagonal blade Lama esagonale
AWL-BTF2412-IK	AWL-SK111345	GN749-G1/8-A	AS 0075	AWL-SGSM1045	UP-1212-AFC	T53	T53SW5

! Eine spätere Demontage der Verschluss-schraube ist nicht mehr möglich.

Once the screw plug is tightened it can not be removed anymore.

Una volta serrata la vite non sarà più possibile rimuoverla

! Hinweis: Passende Anschläge finden Sie auf Seite 86 – 89

Remark: For matching fix stops see page 86 – 89

Nota: I fermi compatibili si trovano a pagina 86 – 89

Unterlagplatte UP-1212-AFC: Mit dieser Unterlagplatte kann statt einem 16x16 Klemmhalter auch ein 12x12 Klemmhalter gespannt werden.

Shim UP-1212-AFC: This shim permits the clamping of a 12x12 holder instead of a 16x16 holder.

Piastra di supporto UP-1212-AFC: Con questa piastra è possibile serrare invece di un adattatore 16x16 un adattatore 12x12.

! Hinweis: Passende Trägerwerkzeuge finden Sie auf Seite 58 – 85

Remark: For matching tool holders see page 58 – 85

Nota: Gli utensili compatibili si trovano a pagina 58 – 85

ARNO Werkzeughalter Langdrehen – mit Innenkühlung / ARNO tool holders for sliding head lathes – with internal cooling / Porta-utensili ARNO per la tornitura cilindrica - con raffreddamento interno

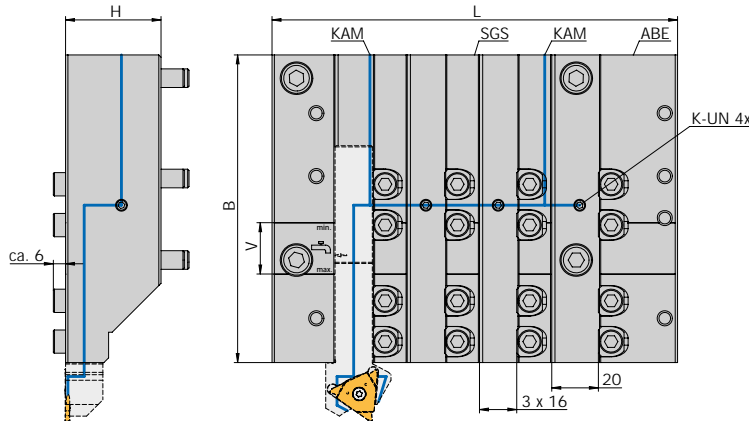

KAM = Kühlmittelanschlussmöglichkeiten
KAM = coolant adapter options
KAM = raccordi del refrigerante

SGS = Sperrgewindestift - bei Bedarf für zwei sperate Druckkammern (Hochdruck)
SGS = locking threaded pin - for two separate pressure chambers (high pressure)
SGS = spina filettata di chiusura - se necessario genera due camere con pressioni separate (alta pressione)

V = In diesem Bereich ist die Kühlmittelversorgung über UN sichergestellt
V = coolant supply is ensured via UN in this range
V = In quest'area l'alimentazione del refrigerante è tramite connessione UN

ABE = Abstechstahlbruchererkennung, Original von Citizen kann montiert werden
ABE = parting insert rupture detection, Citizen original can be fitted
ABE = Rilevamento rottura inserito da troncatore, può essere montato ricambio originale Citizen



Trägerwerkzeuge / Holders / Utensili

Bezeichnung Designation Articolo	L	B	H	16 x 16	20 x 20	V	KAM
AWL-DTF116- IK N	174	132	41	3x	1x	22	G1/8" (2x)

ARNO® SpecialDesign

Hinweis: Auf Anfrage fertigen wir gerne AWL-Schlitten passend zu Ihrem Maschinentyp an.
On request we manufacture AWL heads to fit your machine type.
Su richiesta realizziamo piastre AWL adatti al vostro tipo di macchina.

Ersatzteile / Spare Parts / Ricambi

Trägerwerkzeug Holder Utensile	Spannkeil Clamping wedge Cuneo di bloccaggio	Blindstopfen Dummy plug Tappi ciechi	Verschluss-schraube Screw plug Vite forniti	Sperrgewindestift Locking threaded pin Vite senza testa di arresto	Unterlagplatte Support pad Supporto	Drehmomentquergriff Torque wrench T-handle Chiave dinamometrica con impugnatura a T	Sechskantklinge Hexagonal blade Lama esagonale
AWL-DTF116- IK	AWL-SK111345	GN749-G1/8-A	AS 0075	AWL-SGSM1045	UP-1616-AFC-132	T53	T53SW5

! Eine spätere Demontage der Verschlusschraube ist nicht mehr möglich.
Once the screw plug is tightened it can not be removed anymore.
Una volta serrata la vite non sarà più possibile rimuoverla

! Hinweis: Passende Anschläge finden Sie auf Seite 86 – 89
Remark: For matching fix stops see page 86 – 89
Nota: I fermi compatibili si trovano a pagina 86 – 89

Unterlagplatte UP-1616-AFC-132: Mit dieser Unterlagplatte kann statt einem 20x20 Klemmhalter auch ein 16x16 Klemmhalter gespannt werden.
Shim UP-1616-AFC-132: This shim permits the clamping of a 16x16 holder instead of a 20x20 holder.
Piastra di supporto UP-1616-AFC-132: Con questa piastra è possibile serrare invece di un adattatore 20x20 un adattatore 16x16.

! Hinweis: Passende Trägerwerkzeuge finden Sie auf Seite 58 – 85
Remark: For matching tool holders see page 58 – 85
Nota: Gli utensili compatibili si trovano a pagina 58 – 85

ARNO Werkzeughalter Langdrehen – mit Innenkühlung / ARNO tool holders for sliding head lathes – with internal cooling / Porta-utensili ARNO per la tornitura cilindrica - con raffreddamento interno

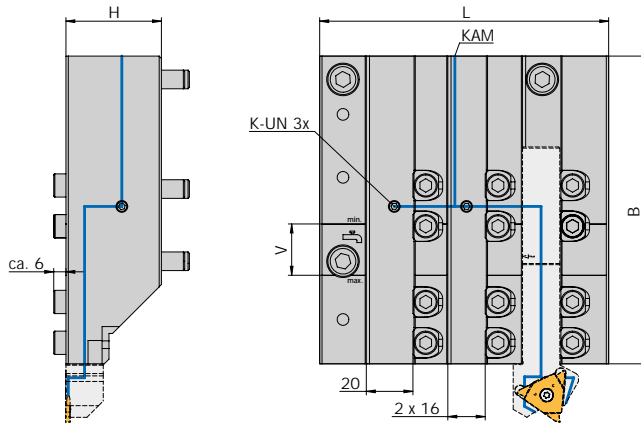

KAM = Kühlmittelanschlussmöglichkeiten
KAM = coolant adapter options
KAM = raccordi del refrigerante

V = In diesem Bereich ist die Kühlmittelversorgung über UN sichergestellt
V = coolant supply is ensured via UN in this range
V = In quest'area l'alimentazione del refrigerante è tramite connessione UN



Trägerwerkzeuge / Holders / Utensili

Bezeichnung Designation Articolo	L	B	H	16 x 16	20 x 20	V	KAM
AWL-DTF216-1K N	124	132	41	2x	1x	22	G1/8"

ARNO® SpecialDesign

Hinweis: Auf Anfrage fertigen wir gerne AWL-Schlitten passend zu Ihrem Maschinentyp an.
On request we manufacture AWL heads to fit your machine type.
Su richiesta realizziamo piastre AWL adatti al vostro tipo di macchina.

Ersatzteile / Spare Parts / Ricambi

Trägerwerkzeug Holder Utensile	Spannkeil Clamping wedge Cuneo di bloccaggio	Blindstopfen Dummy plug Tappi ciechi	Verschluss- schraube Screw plug Vite forniti	Sperrgewindestift Locking threaded pin Vite senza testa di arresto	Unterlagplatte Support pad Supporto	Drehmomentquer- griff Torque wrench T-handle Chiave dinamometrica con impugnatura a T	Sechskantklinge Hexagonal blade Lama esagonale
AWL-DTF116-1K	AWL-SK111345	GN749-G1/8-A	AS 0075	AWL-SGSM1045	UP-1616-AFC-132	T53	T53SW5

! Eine spätere Demontage der Verschlusschraube ist nicht mehr möglich.
Once the screw plug is tightened it can not be removed anymore.
Una volta serrata la vite non sarà più possibile rimuoverla

3 Hinweis: Passende Anschläge finden Sie auf Seite 86 – 89
Remark: For matching fix stops see page 86 – 89
Nota: I fermi compatibili si trovano a pagina 86 – 89

Unterlagplatte UP-1616-AFC-132: Mit dieser Unterlagplatte kann statt einem 20x20 Klemmhalter auch ein 16x16 Klemmhalter gespannt werden.
Shim UP-1616-AFC-132: This shim permits the clamping of a 16x16 holder instead of a 20x20 holder.
Piastra di supporto UP-1616-AFC-132: Con questa piastra è possibile serrare invece di un adattatore 20x20 un adattatore 16x16.

3 Hinweis: Passende Trägerwerkzeuge finden Sie auf Seite 58 – 85
Remark: For matching tool holders see page 58 – 85
Nota: Gli utensili compatibili si trovano a pagina 58 – 85

ARNO Werkzeughalter Langdrehen – mit Innenkühlung / ARNO tool holders for sliding head lathes – with internal cooling / Porta-utensili ARNO per la tornitura cilindrica - con raffreddamento interno

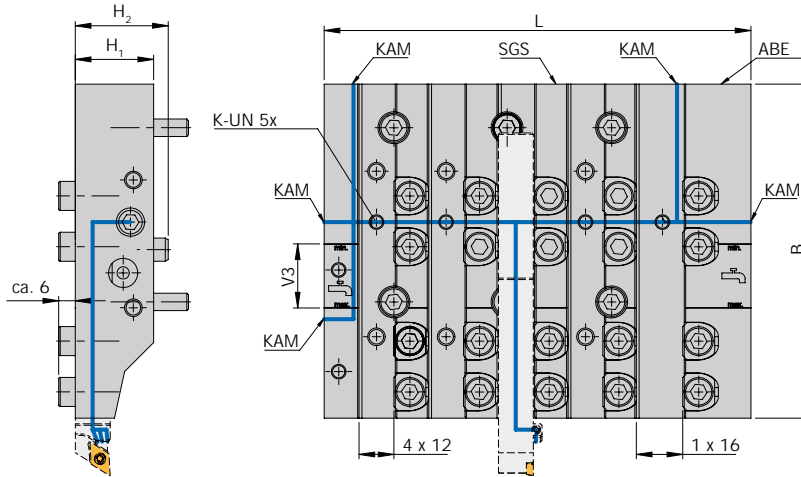

KAM = Kühlmittelanschlussmöglichkeiten
KAM = coolant adapter options
KAM = raccordi del refrigerante

SGS = Sperrgewindestift - bei Bedarf für zwei sperate Druckkammern (Hochdruck)
SGS = locking threaded pin - for two separate pressure chambers (high pressure)
SGS = spina filettata di chiusura - se necessario genera due camere con pressioni separate (alta pressione)

V = In diesem Bereich ist die Kühlmittelversorgung über UN sichergestellt
V = coolant supply is ensured via UN in this range
V = In quest'area l'alimentazione del refrigerante è tramite connessione UN

ABE = Abstechstahlbruchererkennung, Original von Citizen kann montiert werden
ABE = parting insert rupture detection, Citizen original can be fitted
ABE = Rilevamento rottura inserito da troncatura, può essere montato ricambio originale Citizen

Trägerwerkzeuge / Holders / Utensili

Bezeichnung Designation Articolo	L	B	H ₁	H ₂	12 x 12	16 x 16	V	KAM
AWL-GTF3612-IK	147	115	27	32	4x	1x	22	G1/8* (5x)

ARNO® SpecialDesign

Hinweis: Auf Anfrage fertigen wir gerne AWL-Schlitten passend zu Ihrem Maschinentyp an.
On request we manufacture AWL heads to fit your machine type.
Su richiesta realizziamo piastre AWL adatti al vostro tipo di macchina.

Ersatzteile / Spare Parts / Ricambi

Trägerwerkzeug Holder Utensile	Spannkeil Clamping wedge Cuneo di bloccaggio	Blindstopfen Dummy plug Tappi ciechi	Verschluss-schraube Screw plug Vite forniti	Sperrgewindestift Locking threaded pin Vite senza testa di arresto	Unterlagplatte Support pad Supporto	Drehmomentquergriff Torque wrench T-handle Chiave dinamometrica con impugnatura a T	Sechskantklinge Hexagonal blade Lama esagonale
AWL-GTF3612-IK-UK1	AWL-SK111345	GN749-G1/8-A	AS 0075	AWL-SGSM1045	UP-1212-AFC	T53	T53SW5

! Eine spätere Demontage der Verschluss-schraube ist nicht mehr möglich.
Once the screw plug is tightened it can not be removed anymore.
Una volta serrata la vite non sarà più possibile rimuoverla

! Hinweis: Passende Anschläge finden Sie auf Seite 86 – 89
Remark: For matching fix stops see page 86 – 89
Nota: I fermi compatibili si trovano a pagina 86 – 89

Unterlagplatte UP-1212-AFC: Mit dieser Unterlagplatte kann statt einem 16x16 Klemmhalter auch ein 12x12 Klemmhalter gespannt werden.
Shim UP-1212-AFC: This shim permits the clamping of a 12x12 holder instead of a 16x16 holder.
Piastra di supporto UP-1212-AFC: Con questa piastra è possibile serrare invece di un adattatore 16x16 un adattatore 12x12.

! Hinweis: Passende Trägerwerkzeuge finden Sie auf Seite 58 – 85
Remark: For matching tool holders see page 58 – 85
Nota: Gli utensili compatibili si trovano a pagina 58 – 85

ARNO Werkzeughalter Langdrehen – mit Innenkühlung / ARNO tool holders for sliding head lathes – with internal cooling / Porta-utensili ARNO per la tornitura cilindrica - con raffreddamento interno

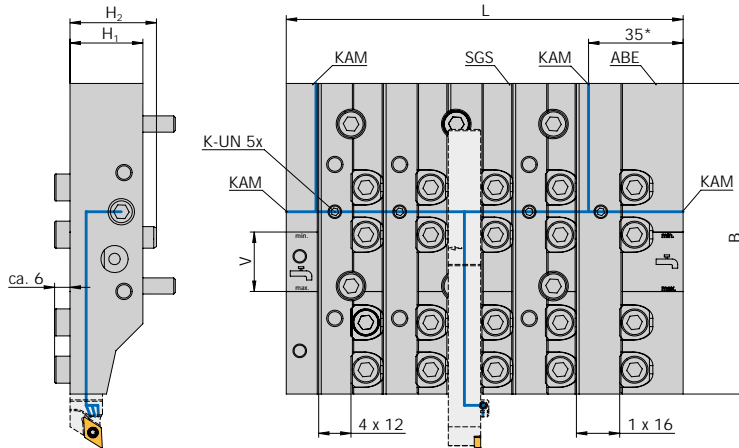

KAM = Kühlmittelanschlussmöglichkeiten
KAM = coolant adapter options
KAM = raccordi del refrigerante

SGS = Sperrgewindestift - bei Bedarf für zwei sperate Druckkammern (Hochdruck)
SGS = locking threaded pin - for two separate pressure chambers (high pressure)
SGS = spina filettata di chiusura - se necessario genera due camere con pressioni separate (alta pressione)

V = In diesem Bereich ist die Kühlmittelversorgung über UN sichergestellt
V = coolant supply is ensured via UN in this range
V = In quest'area l'alimentazione del refrigerante è tramite connessione UN

ABE = Abstechstahlbruchererkennung, Original von Citizen kann montiert werden
ABE = parting insert rupture detection, Citizen original can be fitted
ABE = Rilevamento rottura inserito da troncatura, può essere montato ricambio originale Citizen



Trägerwerkzeuge / Holders / Utensili

Bezeichnung Designation Articolo	L	B	H ₁	H ₂	12 x 12	16 x 16	V	KAM
AWL-GTF3612-IK-UK1 N	147	115	27	32	4x	1x	22	G1/8* (4x)

ARNO® SpecialDesign

Hinweis: Auf Anfrage fertigen wir gerne AWL-Schlitten passend zu Ihrem Maschinentyp an.
On request we manufacture AWL heads to fit your machine type.
Su richiesta realizziamo piastre AWL adatti al vostro tipo di macchina.

Ersatzteile / Spare Parts / Ricambi

Trägerwerkzeug Holder Utensile	Spannkeil Clamping wedge Cuneo di bloccaggio	Blindstopfen Dummy plug Tappi ciechi	Verschluss-schraube Screw plug Vite forniti	Sperrgewindestift Locking threaded pin Vite senza testa di arresto	Unterlagplatte Support pad Supporto	Drehmomentquergriff Torque wrench T-handle Chiave dinamometrica con impugnatura a T	Sechskantklinge Hexagonal blade Lama esagonale
AWL-GTF3612-IK-UK1	AWL-SK111345	GN749-G1/8-A	AS 0075	AWL-SGSM1045	UP-1212-AFC	T53	T53SW5

! Eine spätere Demontage der Verschlusschraube ist nicht mehr möglich.
Once the screw plug is tightened it can not be removed anymore.
Una volta serrata la vite non sarà più possibile rimuoverla

! Hinweis: Passende Anschläge finden Sie auf Seite 86 – 89
Remark: For matching fix stops see page 86 – 89
Nota: I fermi compatibili si trovano a pagina 86 – 89

Unterlagplatte UP-1212-AFC: Mit dieser Unterlagplatte kann statt einem 16x16 Klemmhalter auch ein 12x12 Klemmhalter gespannt werden.
Shim UP-1212-AFC: This shim permits the clamping of a 12x12 holder instead of a 16x16 holder.
Piastra di supporto UP-1212-AFC: Con questa piastra è possibile serrare invece di un adattatore 16x16 un adattatore 12x12.

! Hinweis: Passende Trägerwerkzeuge finden Sie auf Seite 58 – 85
Remark: For matching tool holders see page 58 – 85
Nota: Gli utensili compatibili si trovano a pagina 58 – 85

ARNO Werkzeughalter Langdrehen – mit Innenkühlung / ARNO tool holders for sliding head lathes – with internal cooling / Porta-utensili ARNO per la tornitura cilindrica - con raffreddamento interno

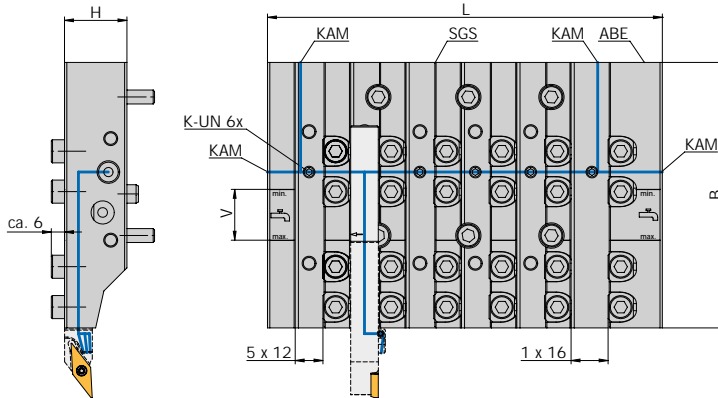

KAM = Kühlmittelanschlussmöglichkeiten
KAM = coolant adapter options
KAM = raccordi del refrigerante

SGS = Sperrgewindestift - bei Bedarf für zwei sperate Druckkammern (Hochdruck)
SGS = locking threaded pin - for two separate pressure chambers (high pressure)
SGS = spina filettata di chiusura - se necessario genera due camere con pressioni separate (alta pressione)

V = In diesem Bereich ist die Kühlmittelversorgung über UN sichergestellt
V = coolant supply is ensured via UN in this range
V = In quest'area l'alimentazione del refrigerante è tramite connessione UN

ABE = Abstechstahlbruchererkennung, Original von Citizen kann montiert werden
ABE = parting insert rupture detection, Citizen original can be fitted
ABE = Rilevamento rottura inserto da troncatura, può essere montato ricambio originale Citizen

Trägerwerkzeuge / Holders / Utensili

Bezeichnung Designation Articolo	L	B	H	12 x 12	16 x 16	V	KAM
AWL-GTF3812-IK	171	115	27	5x	1x	22	G1/8" (4x)

ARNO® SpecialDesign

Hinweis: Auf Anfrage fertigen wir gerne AWL-Schlitten passend zu Ihrem Maschinentyp an.
On request we manufacture AWL heads to fit your machine type.
Su richiesta realizziamo piastre AWL adatti al vostro tipo di macchina.

Ersatzteile / Spare Parts / Ricambi

Trägerwerkzeug Holder Utensile	Spannkeil Clamping wedge Cuneo di bloccaggio	Blindstopfen Dummy plug Tappi ciechi	Verschluss-schraube Screw plug Vite forniti	Sperrgewindestift Locking threaded pin Vite senza testa di arresto	Unterlagplatte Support pad Supporto	Drehmomentquergriff Torque wrench T-handle Chiave dinamometrica con impugnatura a T	Sechskantklinge Hexagonal blade Lama esagonale
AWL-GTF3812-IK	AWL-SK111345	GN749-G1/8-A	AS 0075	AWL-SGSM1045	UP-1212-AFC	T53	T53SW5

! Eine spätere Demontage der Verschlusschraube ist nicht mehr möglich.
Once the screw plug is tightened it can not be removed anymore.
Una volta serrata la vite non sarà più possibile rimuoverla

3 Hinweis: Passende Anschläge finden Sie auf Seite 86 – 89
Remark: For matching fix stops see page 86 – 89
Nota: I fermi compatibili si trovano a pagina 86 – 89

Unterlagplatte UP-1212-AFC: Mit dieser Unterlagplatte kann statt einem 16x16 Klemmhalter auch ein 12x12 Klemmhalter gespannt werden.
Shim UP-1212-AFC: This shim permits the clamping of a 12x12 holder instead of a 16x16 holder.
Piastra di supporto UP-1212-AFC: Con questa piastra è possibile serrare invece di un adattatore 16x16 un adattatore 12x12.

3 Hinweis: Passende Trägerwerkzeuge finden Sie auf Seite 58 – 85
Remark: For matching tool holders see page 58 – 85
Nota: Gli utensili compatibili si trovano a pagina 58 – 85

ARNO Werkzeughalter Langdrehen – mit Innenkühlung / ARNO tool holders for sliding head lathes – with internal cooling / Porta-utensili ARNO per la tornitura cilindrica - con raffreddamento interno

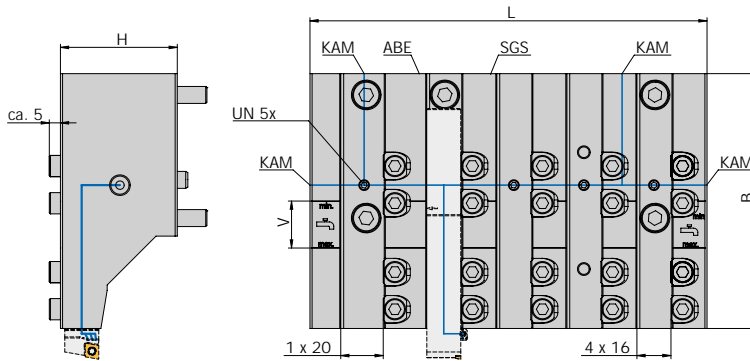

KAM = Kühlmittelanschlussmöglichkeiten
KAM = coolant adapter options
KAM = raccordi del refrigerante

SGS = Sperrgewindestift - bei Bedarf für zwei sperre Druckkammern (Hochdruck)
SGS = locking threaded pin - for two separate pressure chambers (high pressure)
SGS = spina filettata di chiusura - se necessario genera due camere con pressioni separate (alta pressione)

V = In diesem Bereich ist die Kühlmittelversorgung über UN sichergestellt
V = coolant supply is ensured via UN in this range
V = In quest'area l'alimentazione del refrigerante è tramite connessione UN

ABE = Abstechstahlbruchererkennung, Original von Citizen kann montiert werden
ABE = parting insert rupture detection, Citizen original can be fitted
ABE = Rilevamento rottura inserito da troncatura, può essere montato ricambio originale Citizen



Trägerwerkzeuge / Holders / Utensili

Bezeichnung Designation Articolo	L	B	H	16 x 16	20 x 20	V	KAM
AWL-GTF5816- IK N	187	120	55	4x	1x	22	G1/8" (4x)

ARNO® SpecialDesign

Hinweis: Auf Anfrage fertigen wir gerne AWL-Schlitten passend zu Ihrem Maschinentyp an.
On request we manufacture AWL heads to fit your machine type.
Su richiesta realizziamo piastre AWL adatti al vostro tipo di macchina.

Ersatzteile / Spare Parts / Ricambi

Trägerwerkzeug Holder Utensile	Spannkeil Clamping wedge Cuneo di bloccaggio	Blindstopfen Dummy plug Tappi ciechi	Verschluss- schraube Screw plug Vite forniti	Kühlmittel anschluss- winklig, fest Coolant connection, angled, fixed Raccordo angolare del refrigerante, fisso	Sperrgewind- estift Locking threaded pin Vite senza tes- ta di arresto	Unterlag- platte Support pad Supporto	Führungsbol- zen Guide bolts Perno di guida	Drehmoment- quergriff Torque wrench T-handle Chiave dinamo- metrica con impugnatura a T	Sechskant- klinge Hexagonal blade Lama esag- onale
AWL-GTF5816- IK	AWL-SK111345	GN749-G1/8-A	AS 0075	KA 005	AWL-SGSM1045	UP-1616- AFC-120	AWL-FB0908	T53	T53SW5

! Eine spätere Demontage der Verschlusschraube ist nicht mehr möglich.
Once the screw plug is tightened it can not be removed anymore.
Una volta serrata la vite non sarà più possibile rimuoverla

• Hinweis: Passende Anschläge finden Sie auf Seite 86 – 89
Remark: For matching fix stops see page 86 – 89
Nota: I fermi compatibili si trovano a pagina 86 – 89

Unterlagplatte UP-1616-AFC-120: Mit dieser Unterlagplatte kann statt einem 20x20 Klemmhalter auch ein 16x16 Klemmhalter gespannt werden.
Shim UP-1616-AFC-120: This shim permits the clamping of a 16x16 holder instead of a 20x20 holder.
Piastra di supporto UP-1616-AFC-120: Con questa piastra è possibile serrare invece di un adattatore 20x20 un adattatore 16x16.

• Hinweis: Passende Trägerwerkzeuge finden Sie auf Seite 58 – 85
Remark: For matching tool holders see page 58 – 85
Nota: Gli utensili compatibili si trovano a pagina 58 – 85

ARNO Werkzeughalter Langdrehen – mit Innenkühlung / ARNO tool holders for sliding head lathes – with internal cooling / Porta-utensili ARNO per la tornitura cilindrica - con raffreddamento interno

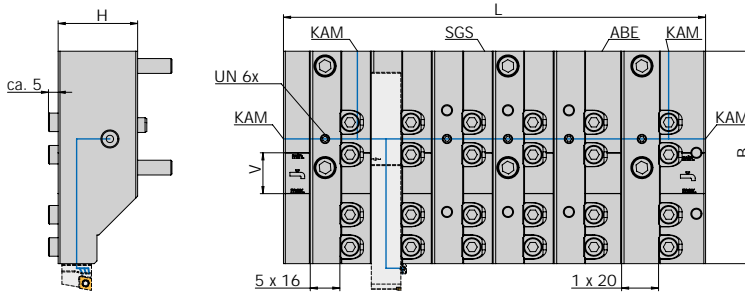

KAM = Kühlmittelanschlussmöglichkeiten
KAM = coolant adapter options
KAM = raccordi del refrigerante

SGS = Sperrgewindestift - bei Bedarf für zwei sperre Druckkammern (Hochdruck)
SGS = locking threaded pin - for two separate pressure chambers (high pressure)
SGS = spina filettata di chiusura - se necessario genera due camere con pressioni separate (alta pressione)

V = In diesem Bereich ist die Kühlmittelversorgung über UN sichergestellt
V = coolant supply is ensured via UN in this range
V = In quest'area l'alimentazione del refrigerante è tramite connessione UN

ABE = Abstechstahlbruchererkennung, Original von Citizen kann montiert werden
ABE = parting insert rupture detection, Citizen original can be fitted
ABE = Rilevamento rottura inserito da troncatore, può essere montato ricambio originale Citizen



Trägerwerkzeuge / Holders / Utensili

Bezeichnung Designation Articolo	L	B	H	16 x 16	20 x 20	V	KAM
AWL-GTF5916- IK N	228,5	115	43	5x	1x	22	G1/8" (4x)

ARNO® SpecialDesign

Hinweis: Auf Anfrage fertigen wir gerne AWL-Schlitten passend zu Ihrem Maschinentyp an.
On request we manufacture AWL heads to fit your machine type.
Su richiesta realizziamo piastre AWL adatti al vostro tipo di macchina.

Ersatzteile / Spare Parts / Ricambi

Trägerwerkzeug Holder Utensile	Spannkeil Clamping wedge Cuneo di bloccaggio	Blindstopfen Dummy plug Tappi ciechi	Verschluss- schraube Screw plug Vite forniti	Kühlmittel- anschluss- winklig, fest Coolant connection, angled, fixed Raccordo angolare del refrigerante, fisso	Sperr- gewindestift Locking threaded pin Vite senza testa di arresto	Unterlag- platte Support pad Supporto	Führungsbol- zen Guide bolts Perno di guida	Drehmoment- quergriff Torque wrench T-handle Chiave dinamo- metrica con impugnatura a T	Sechskant- klinge Hexagonal blade Lama esag- onale
AWL-GTF5916- IK	AWL-SK111345	GN749-G1/8-A	AS 0075	KA 005	AWL-SG- SM1045	UP-1616- AFC-120	AWL-FB0908	T53	T53SW5

! Eine spätere Demontage der Verschlusschraube ist nicht mehr möglich.
Once the screw plug is tightened it can not be removed anymore.
Una volta serrata la vite non sarà più possibile rimuoverla

• Hinweis: Passende Anschläge finden Sie auf Seite 86 – 89
Remark: For matching fix stops see page 86 – 89
Nota: I fermi compatibili si trovano a pagina 86 – 89

Unterlagplatte UP-1616-AFC-120: Mit dieser Unterlagplatte kann statt einem 20x20 Klemmhalter auch ein 16x16 Klemmhalter gespannt werden.
Shim UP-1616-AFC-120: This shim permits the clamping of a 16x16 holder instead of a 20x20 holder.
Piastra di supporto UP-1616-AFC-120: Con questa piastra è possibile serrare invece di un adattatore 20x20 un adattatore 16x16.

• Hinweis: Passende Trägerwerkzeuge finden Sie auf Seite 58 – 85
Remark: For matching tool holders see page 58 – 85
Nota: Gli utensili compatibili si trovano a pagina 58 – 85

ARNO Werkzeughalter Langdrehen – mit Innenkühlung / ARNO tool holders for sliding head lathes – with internal cooling / Portautensili ARNO per la tornitura cilindrica - con raffreddamento interno

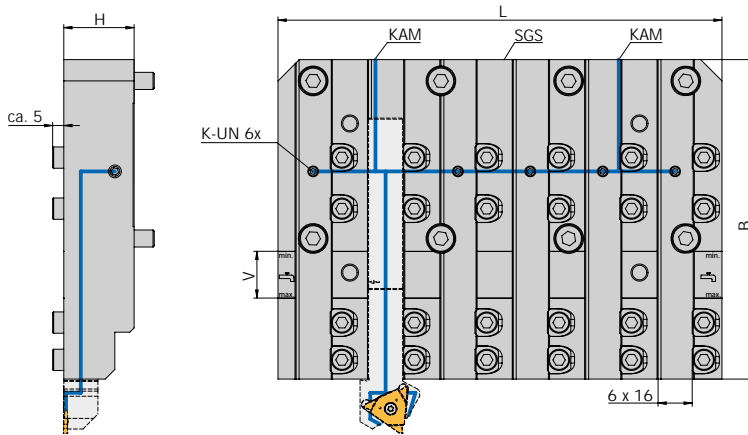

KAM = Kühlmittelanschlussmöglichkeiten
KAM = coolant adapter options
KAM = raccordi del refrigerante

SGS = Sperrgewindestift - bei Bedarf für zwei sperate Druckkammern (Hochdruck)
SGS = locking threaded pin - for two separate pressure chambers (high pressure)
SGS = spina filettata di chiusura - se necessario genera due camere con pressioni separate (alta pressione)

V = In diesem Bereich ist die Kühlmittelversorgung über UN sichergestellt
V = coolant supply is ensured via UN in this range
V = In quest'area l'alimentazione del refrigerante è tramite connessione UN



Trägerwerkzeuge / Holders / Utensili

Bezeichnung Designation Articolo	L	B	H	16 x 16	V	KAM
AWL-DMG-32-8-1-1K N	208,5	150	33	6x	22	G1/8" (2x)

ARNO® SpecialDesign

Hinweis: Auf Anfrage fertigen wir gerne AWL-Schlitten passend zu Ihrem Maschinentyp an.
On request we manufacture AWL heads to fit your machine type.
Su richiesta realizziamo piastre AWL adatti al vostro tipo di macchina.

Ersatzteile / Spare Parts / Ricambi

Trägerwerkzeug Holder Utensile	Spannkeil Clamping wedge Cuneo di bloccaggio	Blindstopfen Dummy plug Tappi ciechi	Verschluss- schraube Screw plug Vite forniti	Kühlmittel- anschluss- winklig, fest Coolant connec- tion, angled, fixed Raccordo angolare del refrigerante, fisso	Sperrgewindestift Locking threaded pin Vite senza testa di arresto	Drehmoment- quergriff Torque wrench T-handle Chiave dinamo- metrica con impugnatura a T	Sechskantklinge Hexagonal blade Lama esagonale
AWL-DMG-32-8-1-1K	AWL-SK111345	GN749-G1/8-A	AS 0075	KA 005	AWL-SGSM1045	T53	T53SW5

! AWL-DMG-32-8-1-1K nur in Verbindung mit AHA 1616-UN-37-80-AFC Anschlag verwenden.
Only use AWL-DMG-32-8-1-1K in conjunction with AHA 1616-UN-37-80-AFC fixed stop.
Utilizzare l'AWL-DMG-32-8-1-1K solo insieme all'elemento di fermo AHA 1616-UN-37-80-AFC.

! Eine spätere Demontage der Verschlusschraube ist nicht mehr möglich.
Once the screw plug is tightened it can not be removed anymore.
Una volta serrata la vite non sarà più possibile rimuoverla

! Hinweis: Passende Anschläge finden Sie auf Seite 86 – 89
Remark: For matching fix stops see page 86 – 89
Nota: I fermi compatibili si trovano a pagina 86 – 89

! Hinweis: Passende Trägerwerkzeuge finden Sie auf Seite 58 – 85
Remark: For matching tool holders see page 58 – 85
Nota: Gli utensili compatibili si trovano a pagina 58 – 85

ARNO Werkzeughalter Langdrehen – mit Innenkühlung / ARNO tool holders for sliding head lathes – with internal cooling / Porta-utensili ARNO per la tornitura cilindrica - con raffreddamento interno

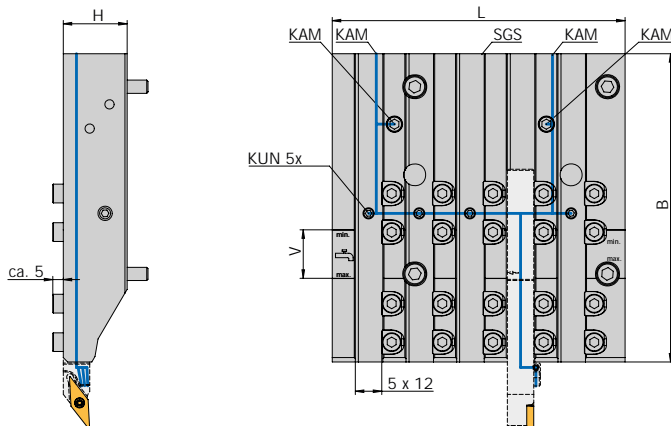

KAM = Kühlmittelanschlussmöglichkeiten

KAM = coolant adapter options

KAM = raccordi del refrigerante

SGS = Sperrgewindestift - bei Bedarf für zwei sperate Druckkammern (Hochdruck)

SGS = locking threaded pin - for two separate pressure chambers (high pressure)
SGS = spina filettata di chiusura - se necessario genera due camere con pressioni separate (alta pressione)

V = In diesem Bereich ist die Kühlmittelversorgung über UN sichergestellt

V = coolant supply is ensured via UN in this range

V = In quest'area l'alimentazione del refrigerante è tramite connessione UN

Trägerwerkzeuge / Holders / Utensili

Bezeichnung Designation Articolo	L	B	H	12 x 12	V	KAM
AWL-SP05010-401-1K	133	140	29	5x	22	G1/8" (4x)

ARNO® SpecialDesign

Hinweis: Auf Anfrage fertigen wir gerne AWL-Schlitten passend zu Ihrem Maschinentyp an.

On request we manufacture AWL heads to fit your machine type.

Su richiesta realizziamo piastre AWL adatti al vostro tipo di macchina.

Ersatzteile / Spare Parts / Ricambi

Trägerwerkzeug Holder Utensile	Spannkeil Clamping wedge Cuneo di bloccaggio	Verschlusschraube Screw plug Vite forniti	Sperrgewindestift Locking threaded pin Vite senza testa di arresto	Kühlmittel-anschluss-gerade Coolant connection, straight Raccordo dritto del refrigerante	Drehmoment-quergriff Torque wrench T-handle Chiave dinamometrica con impugnatura a T	Sechskantklinge Hexagonal blade Lama esagonale
AWL-SP05010-401-1K	AWL-SK091145	AS 0074 / AS 0075	AWL-SGSM1045	KA009	T53	T53SW4

! Eine spätere Demontage der Verschlusschraube ist nicht mehr möglich.
Once the screw plug is tightened it can not be removed anymore.
Una volta serrata la vite non sarà più possibile rimuoverla

! Hinweis: Passende Anschläge finden Sie auf Seite 86 – 89
Remark: For matching fix stops see page 86 – 89
Nota: I fermi compatibili si trovano a pagina 86 – 89

! Hinweis: Passende Trägerwerkzeuge finden Sie auf Seite 58 – 85
Remark: For matching tool holders see page 58 – 85
Nota: Gli utensili compatibili si trovano a pagina 58 – 85

ARNO Werkzeughalter Langdrehen – mit Innenkühlung / ARNO tool holders for sliding head lathes – with internal cooling / Porta-utensili ARNO per la tornitura cilindrica - con raffreddamento interno

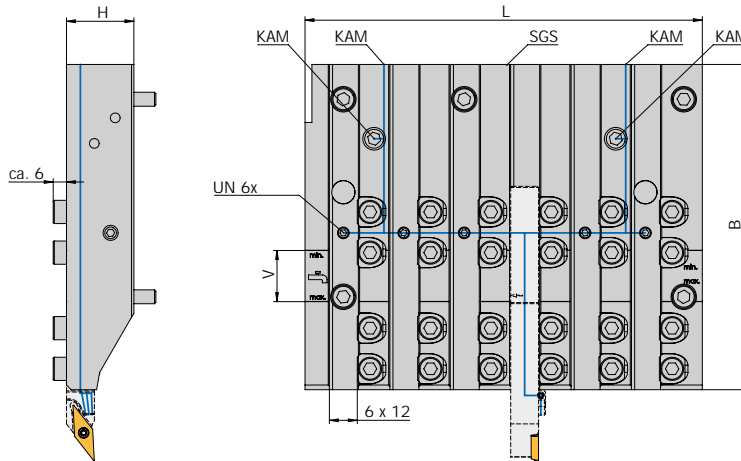

KAM = Kühlmittelanschlussmöglichkeiten

KAM = coolant adapter options

KAM = raccordi del refrigerante

SGS = Sperrgewindestift - bei Bedarf für zwei sperate Druckkammern (Hochdruck)

SGS = locking threaded pin - for two separate pressure chambers (high pressure)

SGS = spina filettata di chiusura - se necessario genera due camere con pressioni separate (alta pressione)

V = In diesem Bereich ist die Kühlmittelversorgung über UN sichergestellt

V = coolant supply is ensured via UN in this range

V = In quest'area l'alimentazione del refrigerante è tramite connessione UN

N NEU/NEW/NUOVO

Trägerwerkzeuge / Holders / Utensili

Bezeichnung Designation Articolo	L	B	H	12 x 12	V	KAM
AWL-SP05010-701-1K N	171	140	29	6x	22	G1/8" (4x)

ARNO® SpecialDesign

Hinweis: Auf Anfrage fertigen wir gerne AWL-Schlitten passend zu Ihrem Maschinentyp an.

On request we manufacture AWL heads to fit your machine type.

Su richiesta realizziamo piastre AWL adatti al vostro tipo di macchina.

Ersatzteile / Spare Parts / Ricambi

Trägerwerkzeug Holder Utensile	Spannkeil Clamping wedge Cuneo di bloccaggio	Blindstopfen Dummy plug Tappi ciechi	Verschluss- schraube Screw plug Vite forniti	Kühlmittel- anschluss- winklig, fest Coolant connec- tion, angled, fixed Raccordo angolare del refrigerante, fisso	Sperrgewindestift Locking threaded pin Vite senza testa di arresto	Drehmoment- quergriff Torque wrench T-handle Chiave dinamo- metrica con impugnatura a T	Sechskantklinge Hexagonal blade Lama esagonale
AWL-SP05010-701-1K	AWL-SK111345	GN749-G1/8-A	AS 0075	KA 005	AWL-SGSM1045	T53	T53SW5

! Eine spätere Demontage der Verschlusschraube ist nicht mehr möglich.

Once the screw plug is tightened it can not be removed anymore.

Una volta serrata la vite non sarà più possibile rimuoverla

! Hinweis: Passende Anschläge finden Sie auf Seite 86 – 89

Remark: For matching fix stops see page 86 – 89

Nota: I fermi compatibili si trovano a pagina 86 – 89

! Hinweis: Passende Trägerwerkzeuge finden Sie auf Seite 58 – 85

Remark: For matching tool holders see page 58 – 85

Nota: Gli utensili compatibili si trovano a pagina 58 – 85

ARNO Werkzeughalter Langdrehen – mit Innenkühlung / ARNO tool holders for sliding head lathes – with internal cooling / Porta-utensili ARNO per la tornitura cilindrica - con raffreddamento interno

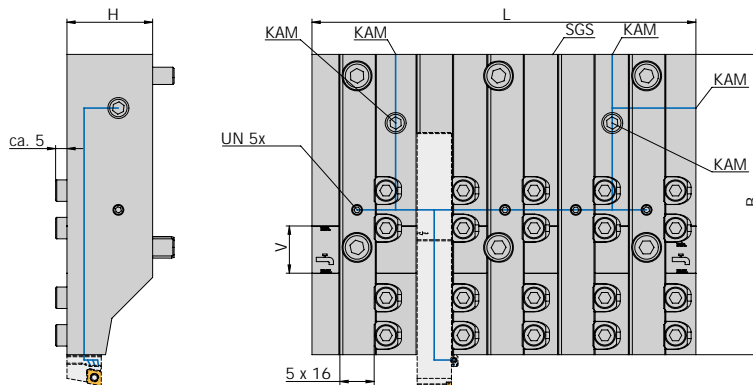

KAM = Kühlmittelanschlussmöglichkeiten

KAM = coolant adapter options

KAM = raccordi del refrigerante

SGS = Sperrgewindestift - bei Bedarf für zwei sperate Druckkammern (Hochdruck)

SGS = locking threaded pin - for two separate pressure chambers (high pressure)

SGS = spina filettata di chiusura - se necessario genera due camere con pressioni separate (alta pressione)

V = In diesem Bereich ist die Kühlmittelversorgung über UN sichergestellt

V = coolant supply is ensured via UN in this range

V = In quest'area l'alimentazione del refrigerante è tramite connessione UN

Trägerwerkzeuge / Holders / Utensili

Bezeichnung Designation Articolo	L	B	H	16 x 16	V	KAM
AWL-ST41000-IK	179	140	40	5x	22	G1/8" (5x)

ARNO® SpecialDesign

Hinweis: Auf Anfrage fertigen wir gerne AWL-Schlitten passend zu Ihrem Maschinentyp an.

On request we manufacture AWL heads to fit your machine type.

Su richiesta realizziamo piastre AWL adatti al vostro tipo di macchina.

Ersatzteile / Spare Parts / Ricambi

Trägerwerkzeug Holder Utensile	Spannkeil Clamping wedge Cuneo di bloccaggio	Blindstopfen Dummy plug Tappi ciechi	Verschluss-schraube Screw plug Vite forniti	Kühlmittel-anschluss-winklig, fest Coolant connection, angled, fixed Raccordo angolare del refrigerante, fisso	Sperrgewindestift Locking threaded pin Vite senza testa di arresto	Drehmoment-quergriff Torque wrench T-handle Chiave dinamometrica con impugnatura a T	Sechskantklinge Hexagonal blade Lama esagonale
AWL-ST41000-IK	AWL-SK111345	GN749-G1/8-A	AS 0075	KA 005	AWL-SGSM1045	T53	T53SW5

! Eine spätere Demontage der Verschluss-schraube ist nicht mehr möglich.
Once the screw plug is tightened it can not be removed anymore.
Una volta serrata la vite non sarà più possibile rimuoverla

! Hinweis: Passende Anschläge finden Sie auf Seite 86 – 89
Remark: For matching fix stops see page 86 – 89
Nota: I fermi compatibili si trovano a pagina 86 – 89

! Hinweis: Passende Trägerwerkzeuge finden Sie auf Seite 58 – 85
Remark: For matching tool holders see page 58 – 85
Nota: Gli utensili compatibili si trovano a pagina 58 – 85

ARNO Werkzeughalter Langdrehen – mit Innenkühlung / ARNO tool holders for sliding head lathes – with internal cooling / Porta-utensili ARNO per la tornitura cilindrica - con raffreddamento interno

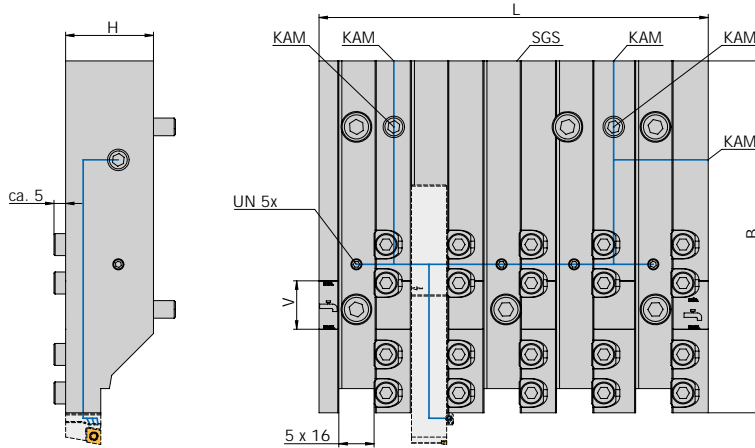

KAM = Kühlmittelanschlussmöglichkeiten
KAM = coolant adapter options
KAM = raccordi del refrigerante

SGS = Sperrgewindestift - bei Bedarf für zwei sperate Druckkammern (Hochdruck)
SGS = locking threaded pin - for two separate pressure chambers (high pressure)
SGS = spina filettata di chiusura - se necessario genera due camere con pressioni separate (alta pressione)

V = In diesem Bereich ist die Kühlmittelversorgung über UN sichergestellt
V = coolant supply is ensured via UN in this range
V = In quest'area l'alimentazione del refrigerante è tramite connessione UN



Trägerwerkzeuge / Holders / Utensili

Bezeichnung Designation Articolo	L	B	H	16 x 16	V	KAM
AWL XB41000-500- IK N	177	160	40	5x	22	G1/8" (5x)

ARNO® SpecialDesign

Hinweis: Auf Anfrage fertigen wir gerne AWL-Schlitten passend zu Ihrem Maschinentyp an.
On request we manufacture AWL heads to fit your machine type.
Su richiesta realizziamo piastre AWL adatti al vostro tipo di macchina.

Ersatzteile / Spare Parts / Ricambi

Trägerwerkzeug Holder Utensile	Spannkeil Clamping wedge Cuneo di bloccaggio	Blindstopfen Dummy plug Tappi ciechi	Verschluss- schraube Screw plug Vite forniti	Kühlmittel- anschluss- winklig, fest Coolant connec- tion, angled, fixed Raccordo angolare del refrigerante, fisso	Sperrgewindestift Locking threaded pin Vite senza testa di arresto	Drehmoment- quergriff Torque wrench T-handle Chiave dinamo- metrica con impugnatura a T	Sechskantklinge Hexagonal blade Lama esagonale
AWL-XB41000-500- IK	AWL-SK111345	GN749-G1/8-A	AS 0075	KA 005	AWL-SGSM1045	T53	T53SW5

! Eine spätere Demontage der Verschlusschraube ist nicht mehr möglich.
Once the screw plug is tightened it can not be removed anymore.
Una volta serrata la vite non sarà più possibile rimuoverla

• Hinweis: Passende Anschläge finden Sie auf Seite 86 – 89
Remark: For matching fix stops see page 86 – 89
Nota: I fermi compatibili si trovano a pagina 86 – 89

• Hinweis: Passende Trägerwerkzeuge finden Sie auf Seite 58 – 85
Remark: For matching tool holders see page 58 – 85
Nota: Gli utensili compatibili si trovano a pagina 58 – 85

ARNO Werkzeughalter Langdrehen – mit Innenkühlung / ARNO tool holders for sliding head lathes – with internal cooling / Porta-utensili ARNO per la tornitura cilindrica - con raffreddamento interno

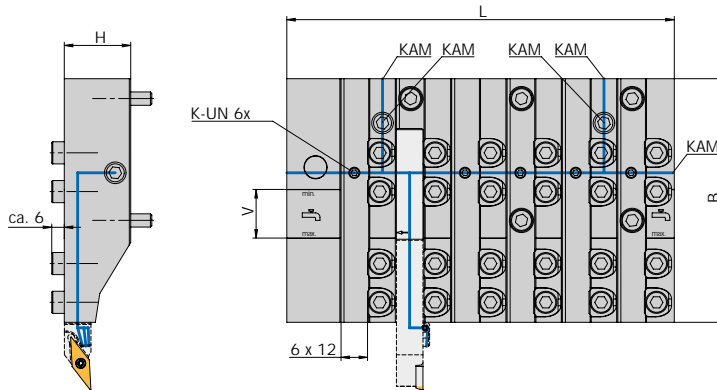

KAM = Kühlmittelanschlussmöglichkeiten

KAM = coolant adapter options

KAM = raccordi del refrigerante

V = In diesem Bereich ist die Kühlmittelversorgung über UN sichergestellt
V = coolant supply is ensured via UN in this range

V = In quest'area l'alimentazione del refrigerante è tramite connessione UN

Trägerwerkzeuge / Holders / Utensili

Bezeichnung Designation Articolo	L	B	H	12 x 12	V	KAM
AWL-0M1-03-1K	175	110	30	6x	22	G1/8" (5x)

ARNO® SpecialDesign

Hinweis: Auf Anfrage fertigen wir gerne AWL-Schlitten passend zu Ihrem Maschinentyp an.

On request we manufacture AWL heads to fit your machine type.

Su richiesta realizziamo piastre AWL adatti al vostro tipo di macchina.

Ersatzteile / Spare Parts / Ricambi

Trägerwerkzeug Holder Utensile	Spannkeil Clamping wedge Cuneo di bloccaggio	Blindstopfen Dummy plug Tappi ciechi	Verschlusschraube Screw plug Vite forniti	Kühlmittel-anschluss-winklig, fest Coolant connection, angled, fixed Raccordo angolare del refrigerante, fisso	Drehmoment-quergriff Torque wrench T-handle Chiave dinamometrica con impugnatura a T	Sechskantklinge Hexagonal blade Lama esagonale
AWL-0M1-03-1K	AWL-SK111345	GN749-G1/8-A	AS 0075	KA 005	T53	T53SW5

! Eine spätere Demontage der Verschlusschraube ist nicht mehr möglich.
Once the screw plug is tightened it can not be removed anymore.
Una volta serrata la vite non sarà più possibile rimuoverla

! Hinweis: Passende Anschläge finden Sie auf Seite 86 – 89
Remark: For matching fix stops see page 86 – 89
Nota: I fermi compatibili si trovano a pagina 86 – 89

! Hinweis: Passende Trägerwerkzeuge finden Sie auf Seite 58 – 85
Remark: For matching tool holders see page 58 – 85
Nota: Gli utensili compatibili si trovano a pagina 58 – 85

ARNO Werkzeughalter Langdrehen – mit Innenkühlung / ARNO tool holders for sliding head lathes – with internal cooling / Porta-utensili ARNO per la tornitura cilindrica - con raffreddamento interno

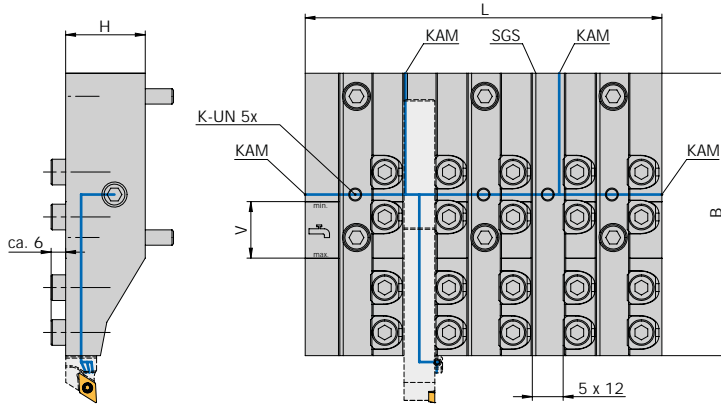

KAM = Kühlmittelanschlussmöglichkeiten

KAM = coolant adapter options

KAM = raccordi del refrigerante

SGS = Sperrgewindestift - bei Bedarf für zwei sperate Druckkammern (Hochdruck)

SGS = locking threaded pin - for two separate pressure chambers (high pressure)

SGS = spina filettata di chiusura - se necessario genera due camere con pressioni separate (alta pressione)

V = In diesem Bereich ist die Kühlmittelversorgung über UN sichergestellt

V = coolant supply is ensured via UN in this range

V = In quest'area l'alimentazione del refrigerante è tramite connessione UN

Trägerwerkzeuge / Holders / Utensili

Bezeichnung Designation Articolo	L	B	H	12 x 12	V	KAM
AWL-0T0-62-010-1K	139	110	31	5x	22	G1/8" (4x)

ARNO® SpecialDesign

Hinweis: Auf Anfrage fertigen wir gerne AWL-Schlitten passend zu Ihrem Maschinentyp an.

On request we manufacture AWL heads to fit your machine type.

Su richiesta realizziamo piastre AWL adatti al vostro tipo di macchina.

Ersatzteile / Spare Parts / Ricambi

Trägerwerkzeug Holder Utensile	Spannkeil Clamping wedge Cuneo di bloccaggio	Blindstopfen Dummy plug Tappi ciechi	Verschlussschraube Screw plug Vite forniti	Sperrgewindestift Locking threaded pin Vite senza testa di arresto	Drehmoment- quergriff Torque wrench T-handle Chiave dinamometrica con impugnatura a T	Sechskantklinge Hexagonal blade Lama esagonale
AWL-0T0-62-010-1K	AWL-SK111345	GN749-G1/8-A	AS 0075	AWL-SGSM1045	T53	T53SW5

! Eine spätere Demontage der Verschlussschraube ist nicht mehr möglich.

Once the screw plug is tightened it can not be removed anymore.

Una volta serrata la vite non sarà più possibile rimuoverla

! Hinweis: Passende Anschläge finden Sie auf Seite 86 – 89

Remark: For matching fix stops see page 86 – 89

Nota: I fermi compatibili si trovano a pagina 86 – 89

! Hinweis: Passende Trägerwerkzeuge finden Sie auf Seite 58 – 85

Remark: For matching tool holders see page 58 – 85

Nota: Gli utensili compatibili si trovano a pagina 58 – 85

ARNO Werkzeughalter Langdrehen – mit Innenkühlung / ARNO tool holders for sliding head lathes – with internal cooling / Porta-utensili ARNO per la tornitura cilindrica - con raffreddamento interno

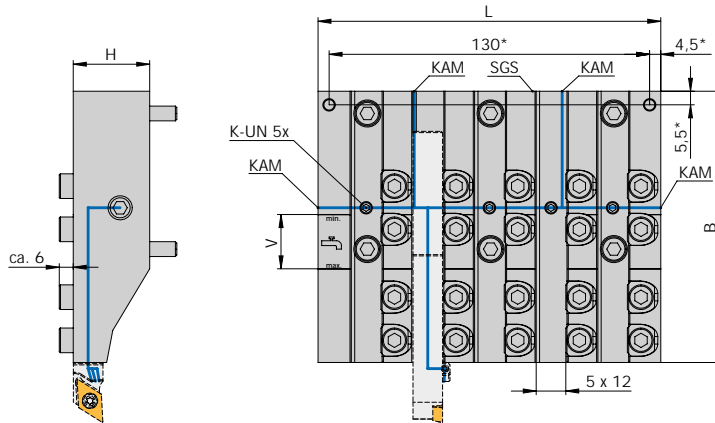

KAM = Kühlmittelanschlussmöglichkeiten

KAM = coolant adapter options

KAM = raccordi del refrigerante

SGS = Sperrgewindestift - bei Bedarf für zwei sperate Druckkammern (Hochdruck)

SGS = locking threaded pin - for two separate pressure chambers (high pressure)

SGS = spina filettata di chiusura - se necessario genera due camere con pressioni separate (alta pressione)

V = In diesem Bereich ist die Kühlmittelversorgung über UN sichergestellt

V = coolant supply is ensured via UN in this range

V = In quest'area l'alimentazione del refrigerante è tramite connessione UN



Trägerwerkzeuge / Holders / Utensili

Bezeichnung Designation Articolo	L	B	H	12 x 12	V	KAM
AWL-0T0-62-010-IK-UK1 N	139	110	31	5x	22	G1/8" (4x)

ARNO® SpecialDesign

Hinweis: Auf Anfrage fertigen wir gerne AWL-Schlitten passend zu Ihrem Maschinentyp an.

On request we manufacture AWL heads to fit your machine type.

Su richiesta realizziamo piastre AWL adatti al vostro tipo di macchina.

Ersatzteile / Spare Parts / Ricambi

Trägerwerkzeug Holder Utensile	Spannkeil Clamping wedge Cuneo di bloccaggio	Blindstopfen Dummy plug Tappi ciechi	Verschlusschraube Screw plug Vite forniti	Sperrgewindestift Locking threaded pin Vite senza testa di arresto	Drehmoment- quergriff Torque wrench T-handle Chiave dinamometrica con impugnatura a T	Sechskantklinge Hexagonal blade Lama esagonale
AWL-0T0-62-010-IK-UK1	AWL-SK111345	GN749-G1/8-A	AS 0075	AWL-SGSM1045	T53	T53SW5

! Eine spätere Demontage der Verschlusschraube ist nicht mehr möglich.

Once the screw plug is tightened it can not be removed anymore.

Una volta serrata la vite non sarà più possibile rimuoverla

• Hinweis: Passende Anschläge finden Sie auf Seite 86 – 89

Remark: For matching fix stops see page 86 – 89

Nota: I fermi compatibili si trovano a pagina 86 – 89

• Hinweis: Passende Trägerwerkzeuge finden Sie auf Seite 58 – 85

Remark: For matching tool holders see page 58 – 85

Nota: Gli utensili compatibili si trovano a pagina 58 – 85

ARNO Werkzeughalter Langdrehen – mit Innenkühlung / ARNO tool holders for sliding head lathes – with internal cooling / Porta-utensili ARNO per la tornitura cilindrica - con raffreddamento interno

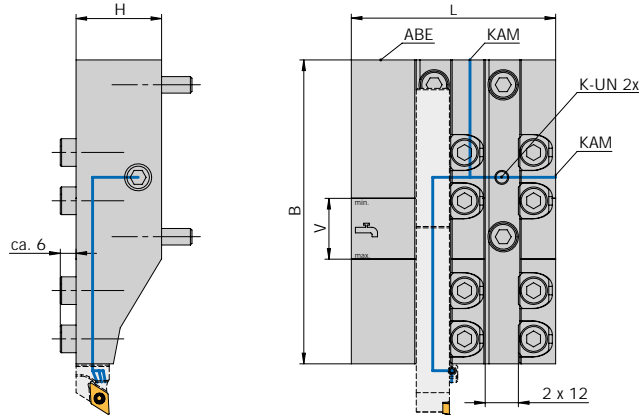

KAM = Kühlmittelanschlussmöglichkeiten

KAM = coolant adapter options

KAM = raccordi del refrigerante

V = In diesem Bereich ist die Kühlmittelversorgung über UN sichergestellt
V = coolant supply is ensured via UN in this range

V = In quest'area l'alimentazione del refrigerante è tramite connessione UN

ABE = Abstechstahlbrucherennung, Original von Star kann montiert werden

ABE = parting insert rupture detection, Star original can be fitted

ABE = Rilevamento rottura inserto da troncatura, può essere montato ricambio originale Star

Trägerwerkzeuge / Holders / Utensili

Bezeichnung Designation Articolo	L	B	H	12 x 12	V	KAM
AWL-0T0-67-010-1K	74	110	31	2x	22	G1/8" (2x)

ARNO® SpecialDesign

Hinweis: Auf Anfrage fertigen wir gerne AWL-Schlitten passend zu Ihrem Maschinentyp an.

On request we manufacture AWL heads to fit your machine type.

Su richiesta realizziamo piastre AWL adatti al vostro tipo di macchina.

Ersatzteile / Spare Parts / Ricambi

Trägerwerkzeug Holder Utensile	Spannkeil Clamping wedge Cuneo di bloccaggio	Blindstopfen Dummy plug Tappi ciechi	Verschlusschraube Screw plug Vite forniti	Drehmomentquergriff Torque wrench T-handle Chiave dinamometrica con impugnatura a T	Sechskantklinge Hexagonal blade Lama esagonale
AWL-0T0-67-010-1K	AWL-SK111345	GN749-G1/8-A	AS 0075	T53	T53SW5

! Eine spätere Demontage der Verschlusschraube ist nicht mehr möglich.
Once the screw plug is tightened it can not be removed anymore.

Una volta serrata la vite non sarà più possibile rimuoverla

3 Hinweis: Passende Anschläge finden Sie auf Seite 86 – 89

Remark: For matching fix stops see page 86 – 89

Nota: I fermi compatibili si trovano a pagina 86 – 89

3 Hinweis: Passende Trägerwerkzeuge finden Sie auf Seite 58 – 85

Remark: For matching tool holders see page 58 – 85

Nota: Gli utensili compatibili si trovano a pagina 58 – 85

ARNO Werkzeughalter Langdrehen – mit Innenkühlung / ARNO tool holders for sliding head lathes – with internal cooling / Porta-utensili ARNO per la tornitura cilindrica - con raffreddamento interno

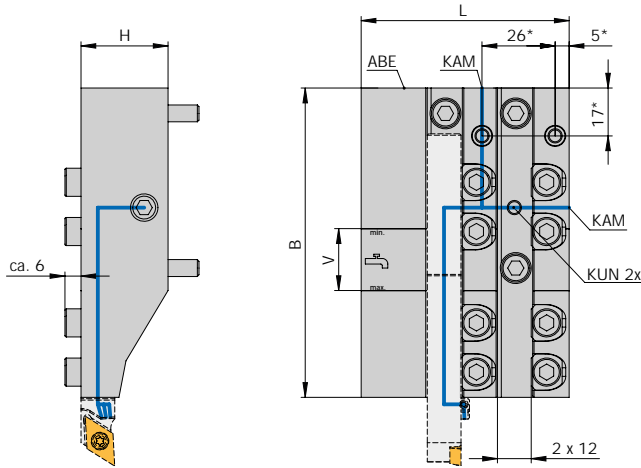

KAM = Kühlmittelanschlussmöglichkeiten

KAM = coolant adapter options

KAM = raccordi del refrigerante

V = In diesem Bereich ist die Kühlung gesichert über UN sichergestellt

V = coolant supply is ensured via UN in this range

V = In quest'area l'alimentazione del refrigerante è tramite connessione UN

ABE = Abstechstahlbrucherennung, Original von Star kann montiert werden

ABE = parting insert rupture detection, Star original can be fitted

ABE = Rilevamento rottura inserto da troncatura, può essere montato ricambio originale Star

N NEU/NEW/NUOVO

Trägerwerkzeuge / Holders / Utensili

Bezeichnung Designation Articolo	L	B	H	12 x 12	V	KAM
AWL-0T0-67-010-IK-UK1 N	74	110	31	2x	22	G1/8" (2x)

ARNO® SpecialDesign

Hinweis: Auf Anfrage fertigen wir gerne AWL-Schlitten passend zu Ihrem Maschinentyp an.

On request we manufacture AWL heads to fit your machine type.

Su richiesta realizziamo piastre AWL adatti al vostro tipo di macchina.

Ersatzteile / Spare Parts / Ricambi

Trägerwerkzeug Holder Utensile	Spannkeil Clamping wedge Cuneo di bloccaggio	Blindstopfen Dummy plug Tappi ciechi	Verschlusschraube Screw plug Vite forniti	Drehmomentquergriff Torque wrench T-handle Chiave dinamometrica con impugnatura a T	Sechskantklinge Hexagonal blade Lama esagonale
AWL-0T0-67-010-IK-UK1	AWL-SK111345	GN749-G1/8-A	AS 0075	T53	T53SW5

! Eine spätere Demontage der Verschlusschraube ist nicht mehr möglich.
Once the screw plug is tightened it can not be removed anymore.
Una volta serrata la vite non sarà più possibile rimuoverla

3 Hinweis: Passende Anschläge finden Sie auf Seite 86 – 89
Remark: For matching fix stops see page 86 – 89
Nota: I fermi compatibili si trovano a pagina 86 – 89

3 Hinweis: Passende Trägerwerkzeuge finden Sie auf Seite 58 – 85
Remark: For matching tool holders see page 58 – 85
Nota: Gli utensili compatibili si trovano a pagina 58 – 85

ARNO Werkzeughalter Langdrehen – mit Innenkühlung / ARNO tool holders for sliding head lathes – with internal cooling / Porta-utensili ARNO per la tornitura cilindrica - con raffreddamento interno

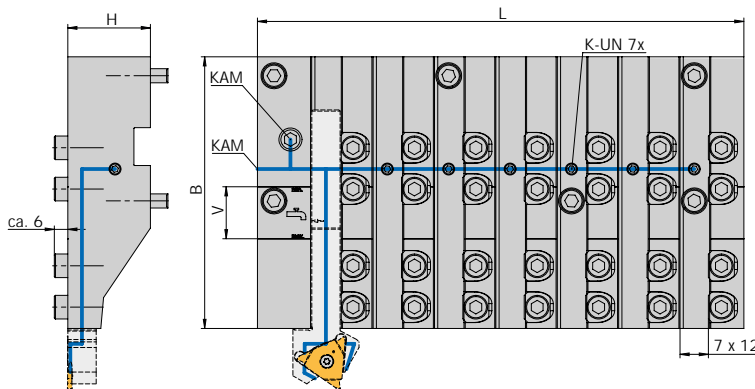

KAM = Kühlmittelanschlussmöglichkeiten

KAM = coolant adapter options

KAM = raccordi del refrigerante

V = In diesem Bereich ist die Kühlung über UN sichergestellt

V = coolant supply is ensured via UN in this range

V = In quest'area l'alimentazione del refrigerante è tramite connessione UN



Trägerwerkzeuge / Holders / Utensili

Bezeichnung Designation Articolo	L	B	H	12 x 12	V	KAM
AWL-1B101-011-IK N	206	115	35	7x	22	G1/8" (2x)

ARNO® SpecialDesign

Hinweis: Auf Anfrage fertigen wir gerne AWL-Schlitten passend zu Ihrem Maschinentyp an.

On request we manufacture AWL heads to fit your machine type.

Su richiesta realizziamo piastre AWL adatti al vostro tipo di macchina.

Ersatzteile / Spare Parts / Ricambi

Trägerwerkzeug Holder Utensile	Spannkeil Clamping wedge Cuneo di bloccaggio	Blindstopfen Dummy plug Tappi ciechi	Verschlusschraube Screw plug Vite forniti	Kühlmittel-anschluss-winklig, fest Coolant connection, angled, fixed Raccordo angolare del refrigerante, fisso	Drehmoment-quergriff Torque wrench T-handle Chiave dinamometrica con impugnatura a T	Sechskantklinge Hexagonal blade Lama esagonale
AWL-1B101-011-IK	AWL-SK111345	GN749-G1/8-A	AS 0075	KA 005	T53	T53SW5

! Eine spätere Demontage der Verschlußschraube ist nicht mehr möglich.

Once the screw plug is tightened it can not be removed anymore.

Una volta serrata la vite non sarà più possibile rimuoverla

• Hinweis: Passende Anschläge finden Sie auf Seite 86 – 89

Remark: For matching fix stops see page 86 – 89

Nota: I fermi compatibili si trovano a pagina 86 – 89

• Hinweis: Passende Trägerwerkzeuge finden Sie auf Seite 58 – 85

Remark: For matching tool holders see page 58 – 85

Nota: Gli utensili compatibili si trovano a pagina 58 – 85

ARNO Werkzeughalter Langdrehen – mit Innenkühlung / ARNO tool holders for sliding head lathes – with internal cooling / Porta-utensili ARNO per la tornitura cilindrica - con raffreddamento interno

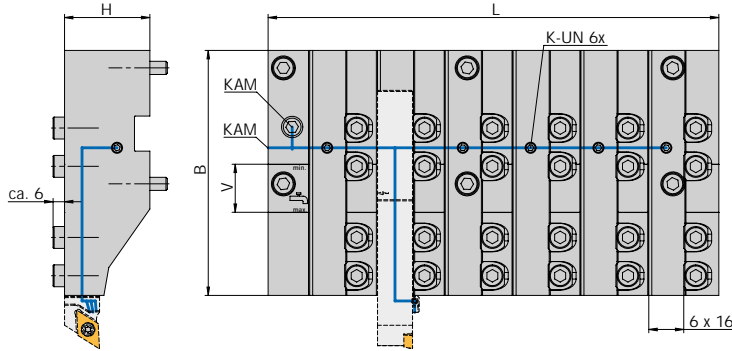

KAM = Kühlmittelanschlussmöglichkeiten

KAM = coolant adapter options

KAM = raccordi del refrigerante

V = In diesem Bereich ist die Kühlung über UN sichergestellt

V = coolant supply is ensured via UN in this range

V = In quest'area l'alimentazione del refrigerante è tramite connessione UN



Trägerwerkzeuge / Holders / Utensili

Bezeichnung Designation Articolo	L	B	H	16 x 16	V	KAM
AWL-1B102-011-1K N	206	112	39	6x	22	G1/8" (2x)

ARNO® SpecialDesign

Hinweis: Auf Anfrage fertigen wir gerne AWL-Schlitten passend zu Ihrem Maschinentyp an.

On request we manufacture AWL heads to fit your machine type.

Su richiesta realizziamo piastre AWL adatti al vostro tipo di macchina.

Ersatzteile / Spare Parts / Ricambi

Trägerwerkzeug Holder Utensile	Spannkeil Clamping wedge Cuneo di bloccaggio	Blindstopfen Dummy plug Tappi ciechi	Verschlusschraube Screw plug Vite forniti	Kühlmittel-anschluss-winklig, fest Coolant connection, angled, fixed Raccordo angolare del refrigerante, fisso	Drehmoment-quergriff Torque wrench T-handle Chiave dinamometrica con impugnatura a T	Sechskantklinge Hexagonal blade Lama esagonale
AWL-1B102-011-1K	AWL-SK111345	GN749-G1/8-A	AS 0075	KA 005	T53	T53SW5

! Eine spätere Demontage der Verschlusschraube ist nicht mehr möglich.

Once the screw plug is tightened it can not be removed anymore.

Una volta serrata la vite non sarà più possibile rimuoverla

• Hinweis: Passende Anschläge finden Sie auf Seite 86 – 89

Remark: For matching fix stops see page 86 – 89

Nota: I fermi compatibili si trovano a pagina 86 – 89

• Hinweis: Passende Trägerwerkzeuge finden Sie auf Seite 58 – 85

Remark: For matching tool holders see page 58 – 85

Nota: Gli utensili compatibili si trovano a pagina 58 – 85

ARNO Werkzeughalter Langdrehen – mit Innenkühlung / ARNO tool holders for sliding head lathes – with internal cooling / Porta-utensili ARNO per la tornitura cilindrica - con raffreddamento interno

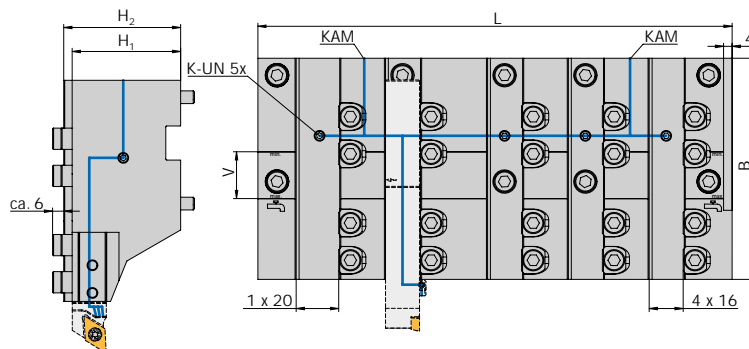

KAM = Kühlmittelanschlussmöglichkeiten

KAM = coolant adapter options

KAM = raccordi del refrigerante

V = In diesem Bereich ist die Kühlmittelversorgung über UN sichergestellt

V = coolant supply is ensured via UN in this range

V = In quest'area l'alimentazione del refrigerante è tramite connessione UN



Trägerwerkzeuge / Holders / Utensili

Bezeichnung Designation Articolo	L	B	H ₁	H ₂	16 x 16	20 x 20	V	KAM
AWL-1C0-62-010-1K N	223	104	51	55	4x	1x	22	G1/8" (2x)

ARNO® SpecialDesign

Hinweis: Auf Anfrage fertigen wir gerne AWL-Schlitten passend zu Ihrem Maschinentyp an.

On request we manufacture AWL heads to fit your machine type.

Su richiesta realizziamo piastre AWL adatti al vostro tipo di macchina.

Ersatzteile / Spare Parts / Ricambi

Trägerwerkzeug Holder Utensile	Spannkeil Clamping wedge Cuneo di bloccaggio	Blindstopfen Dummy plug Tappi ciechi	Verschluss- schraube Screw plug Vite forniti	Kühlmittel- anschluss- winklig, fest Coolant connec- tion, angled, fixed Raccordo angolare del refrigerante, fisso	Unterlagplatte Support pad Supporto	Drehmoment- quergriff Torque wrench T-handle Chiave dinamo- metrica con impugnatura a T	Sechskantklinge Hexagonal blade Lama esagonale
AWL-1C0-62-010-1K	AWL-SK111345	GN749-G1/8-A	AS 0075	KA 005	UP-1616-AFC-104	T53	T53SW5

! Eine spätere Demontage der Verschlusschraube ist nicht mehr möglich.

Once the screw plug is tightened it can not be removed anymore.

Una volta serrata la vite non sarà più possibile rimuoverla

! Hinweis: Passende Anschläge finden Sie auf Seite 86 – 89

Remark: For matching fix stops see page 86 – 89

Nota: I fermi compatibili si trovano a pagina 86 – 89

Unterlagplatte UP-1616-AFC-120: Mit dieser Unterlagplatte kann statt einem 20x20 Klemmhalter auch ein 16x16 Klemmhalter gespannt werden.

Shim UP-1616-AFC-120: This shim permits the clamping of a 16x16 holder instead of a 20x20 holder.

Piastra di supporto UP-1616-AFC-120: Con questa piastra è possibile serrare invece di un adattatore 20x20 un adattatore 16x16.

! Hinweis: Passende Trägerwerkzeuge finden Sie auf Seite 58 – 85

Remark: For matching tool holders see page 58 – 85

Nota: Gli utensili compatibili si trovano a pagina 58 – 85

ARNO Werkzeughalter Langdrehen – mit Innenkühlung / ARNO tool holders for sliding head lathes – with internal cooling / Porta-utensili ARNO per la tornitura cilindrica - con raffreddamento interno

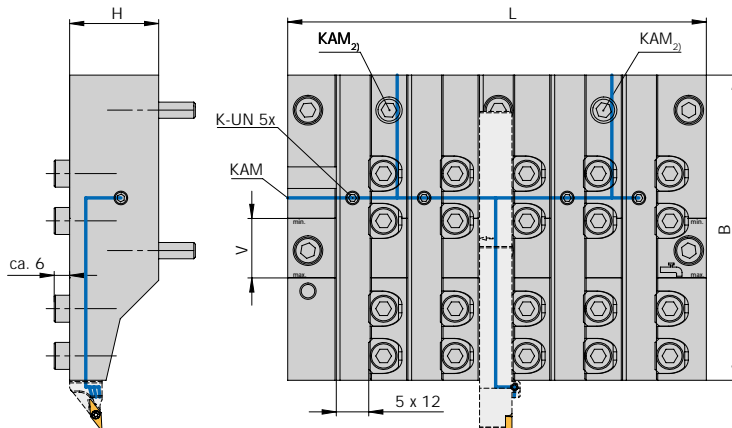

KAM = Kühlmittelanschlussmöglichkeiten

KAM = coolant adapter options

KAM = raccordi del refrigerante

V = In diesem Bereich ist die Kühlung über UN sichergestellt

V = coolant supply is ensured via UN in this range

V = In quest'area l'alimentazione del refrigerante è tramite connessione UN

Trägerwerkzeuge / Holders / Utensili

Bezeichnung Designation Articolo	L	B	H	12 x 12	V	KAM
AWL-421-01-010-1K	155	113	33	5x	22	G1/8" (3x)

ARNO® SpecialDesign

Hinweis: Auf Anfrage fertigen wir gerne AWL-Schlitten passend zu Ihrem Maschinentyp an.

On request we manufacture AWL heads to fit your machine type.

Su richiesta realizziamo piastre AWL adatti al vostro tipo di macchina.

Ersatzteile / Spare Parts / Ricambi

Trägerwerkzeug Holder Utensile	Spannkeil Clamping wedge Cuneo di bloccaggio	Blindstopfen Dummy plug Tappi ciechi	Verschlussschraube Screw plug Vite forniti	Kühlmittel-anschluss-winklig, fest Coolant connection, angled, fixed Raccordo angolare del refrigerante, fisso	Drehmoment-quergriff Torque wrench T-handle Chiave dinamometrica con impugnatura a T	Sechskantklinge Hexagonal blade Lama esagonale
AWL-421-01-010-1K	AWL-SK111345	GN749-G1/8-A	AS 0075	KA 005	T53	T53SW5

! Eine spätere Demontage der Verschlussschraube ist nicht mehr möglich.

Once the screw plug is tightened it can not be removed anymore.

Una volta serrata la vite non sarà più possibile rimuoverla

! Hinweis: Passende Anschläge finden Sie auf Seite 86 – 89

Remark: For matching fix stops see page 86 – 89

Nota: I fermi compatibili si trovano a pagina 86 – 89

! Hinweis: Passende Trägerwerkzeuge finden Sie auf Seite 58 – 85

Remark: For matching tool holders see page 58 – 85

Nota: Gli utensili compatibili si trovano a pagina 58 – 85

ARNO Werkzeughalter Langdrehen – mit Innenkühlung / ARNO tool holders for sliding head lathes – with internal cooling / Porta-utensili ARNO per la tornitura cilindrica - con raffreddamento interno

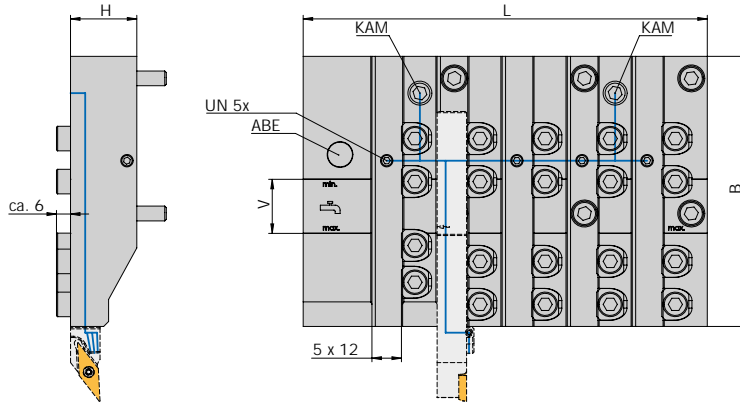

KAM = Kühlmittelanschlussmöglichkeiten

KAM = coolant adapter options

KAM = raccordi del refrigerante

V = In diesem Bereich ist die Kühlmittelversorgung über UN sichergestellt

V = coolant supply is ensured via UN in this range

V = In quest'area l'alimentazione del refrigerante è tramite connessione UN

ABE = Abstechstahlbrucherkennung, Original von Star kann montiert werden

ABE = parting insert rupture detection, Star original can be fitted

ABE = Rilevamento rottura inserto da troncatura, può essere montato ricambio originale Star

N NEU/NEW/NUOVO

Trägerwerkzeuge / Holders / Utensili

Bezeichnung Designation Articolo	L	B	H	12 x 12	V	KAM
AWL-481-01-010- IK N	164,5	110	27	5x	22	G1/8" (2x)

ARNO® SpecialDesign

Hinweis: Auf Anfrage fertigen wir gerne AWL-Schlitten passend zu Ihrem Maschinentyp an.

On request we manufacture AWL heads to fit your machine type.

Su richiesta realizziamo piastre AWL adatti al vostro tipo di macchina.

Ersatzteile / Spare Parts / Ricambi

Trägerwerkzeug Holder Utensile	Spannkeil Clamping wedge Cuneo di bloccaggio	Blindstopfen Dummy plug Tappi ciechi	Verschlussschraube Screw plug Vite forniti	Kühlmittel-anschluss-winklig, fest Coolant connection, angled, fixed Raccordo angolare del refrigerante, fisso	Drehmoment-quergriff Torque wrench T-handle Chiave dinamometrica con impugnatura a T	Sechskantklinge Hexagonal blade Lama esagonale
AWL-481-01-010- IK	AWL-SK111345	GN749-G1/8-A	AS 0075	KA 005	T53	T53SW5

! Eine spätere Demontage der Verschlussschraube ist nicht mehr möglich.

Once the screw plug is tightened it can not be removed anymore.

Una volta serrata la vite non sarà più possibile rimuoverla

! Hinweis: Passende Anschläge finden Sie auf Seite 86 – 89

Remark: For matching fix stops see page 86 – 89

Nota: I fermi compatibili si trovano a pagina 86 – 89

! Hinweis: Passende Trägerwerkzeuge finden Sie auf Seite 58 – 85

Remark: For matching tool holders see page 58 – 85

Nota: Gli utensili compatibili si trovano a pagina 58 – 85

ARNO Werkzeughalter Langdrehen – mit Innenkühlung / ARNO tool holders for sliding head lathes – with internal cooling / Porta-utensili ARNO per la tornitura cilindrica - con raffreddamento interno

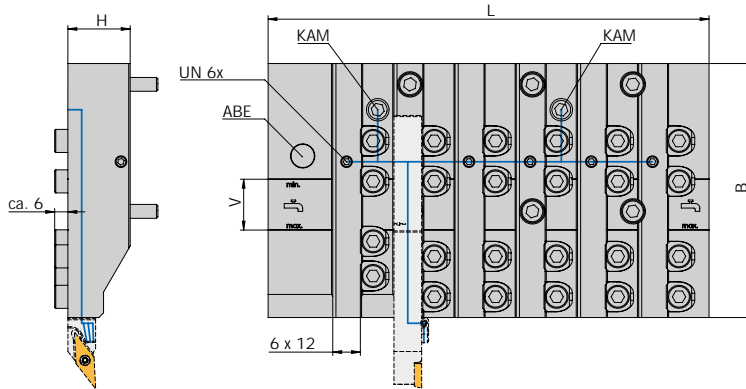

KAM = Kühlmittelanschlussmöglichkeiten

KAM = coolant adapter options

KAM = raccordi del refrigerante

V = In diesem Bereich ist die Kühlmittelversorgung über UN sichergestellt
V = coolant supply is ensured via UN in this range

V = In quest'area l'alimentazione del refrigerante è tramite connessione UN

ABE = Abstechstahlbrucherkennung, Original von Star kann montiert werden

ABE = parting insert rupture detection, Star original can be fitted

ABE = Rilevamento rottura inserto da troncatura, può essere montato ricambio originale Star



Trägerwerkzeuge / Holders / Utensili

Bezeichnung Designation Articolo	L	B	H	12 x 12	V	KAM
AWL-481-02-00-1K N	191	110	27	6x	22	G1/8" (2x)

ARNO® SpecialDesign

Hinweis: Auf Anfrage fertigen wir gerne AWL-Schlitten passend zu Ihrem Maschinentyp an.

On request we manufacture AWL heads to fit your machine type.

Su richiesta realizziamo piastre AWL adatti al vostro tipo di macchina.

Ersatzteile / Spare Parts / Ricambi

Trägerwerkzeug Holder Utensile	Spannkeil Clamping wedge Cuneo di bloccaggio	Blindstopfen Dummy plug Tappi ciechi	Verschlusschraube Screw plug Vite forniti	Kühlmittel-anschluss-winklig, fest Coolant connection, angled, fixed Raccordo angolare del refrigerante, fisso	Drehmoment-quergriff Torque wrench T-handle Chiave dinamometrica con impugnatura a T	Sechskantklinge Hexagonal blade Lama esagonale
AWL-481-02-00-1K	AWL-SK111345	GN749-G1/8-A	AS 0075	KA 005	T53	T53SW5

! Eine spätere Demontage der Verschlußschraube ist nicht mehr möglich.

Once the screw plug is tightened it can not be removed anymore.

Una volta serrata la vite non sarà più possibile rimuoverla

! Hinweis: Passende Anschläge finden Sie auf Seite 86 – 89

Remark: For matching fix stops see page 86 – 89

Nota: I fermi compatibili si trovano a pagina 86 – 89

! Hinweis: Passende Trägerwerkzeuge finden Sie auf Seite 58 – 85

Remark: For matching tool holders see page 58 – 85

Nota: Gli utensili compatibili si trovano a pagina 58 – 85

ARNO Werkzeughalter Langdrehen – mit Innenkühlung / ARNO tool holders for sliding head lathes – with internal cooling / Porta-utensili ARNO per la tornitura cilindrica - con raffreddamento interno

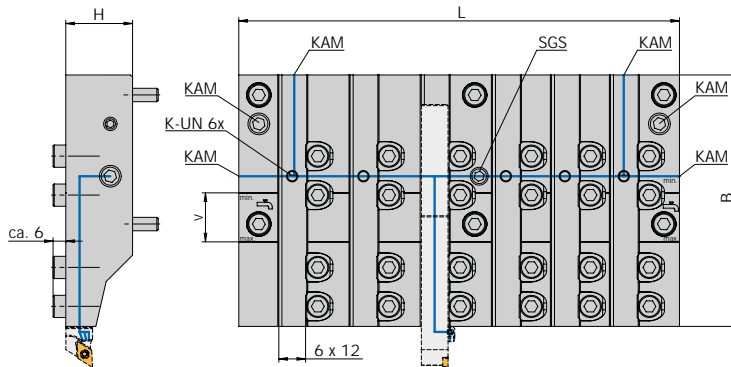

KAM = Kühlmittelanschlussmöglichkeiten
KAM = coolant adapter options
KAM = raccordi del refrigerante

SGS = Sperrgewindestift - bei Bedarf für zwei sperate Druckkammern (Hochdruck)
SGS = locking threaded pin - for two separate pressure chambers (high pressure)
SGS = spina filettata di chiusura - se necessario genera due camere con pressioni separate (alta pressione)

V = In diesem Bereich ist die Kühlmittelversorgung über UN sichergestellt
V = coolant supply is ensured via UN in this range
V = In quest'area l'alimentazione del refrigerante è tramite connessione UN

Trägerwerkzeuge / Holders / Utensili

Bezeichnung Designation Articolo	L	B	H	12 x 12	V	KAM
AWL-541-01-010-1K	198	113	30	6x	22	G1/8" (6x)

ARNO® SpecialDesign

Hinweis: Auf Anfrage fertigen wir gerne AWL-Schlitten passend zu Ihrem Maschinentyp an.
On request we manufacture AWL heads to fit your machine type.
Su richiesta realizziamo piastre AWL adatti al vostro tipo di macchina.

Ersatzteile / Spare Parts / Ricambi

Trägerwerkzeug Holder Utensile	Spannkeil Clamping wedge Cuneo di bloccaggio	Blindstopfen Dummy plug Tappi ciechi	Verschlusschraube Screw plug Vite forniti	Sperrgewindestift Locking threaded pin Vite senza testa di arresto	Drehmoment- quergriff Torque wrench T-handle Chiave dinamometrica con impugnatura a T	Sechskant Klinge Hexagonal blade Lama esagonale
AWL-541-01-010-1K	AWL-SK111345	GN749-G1/8-A	AS 0075	AWL-SGSM0818	T53	T53SW5

! Eine spätere Demontage der Verschlußschraube ist nicht mehr möglich.
Once the screw plug is tightened it can not be removed anymore.
Una volta serrata la vite non sarà più possibile rimuoverla

! Hinweis: Passende Anschläge finden Sie auf Seite 86 – 89
Remark: For matching fix stops see page 86 – 89
Nota: I fermi compatibili si trovano a pagina 86 – 89

! Hinweis: Passende Trägerwerkzeuge finden Sie auf Seite 58 – 85
Remark: For matching tool holders see page 58 – 85
Nota: Gli utensili compatibili si trovano a pagina 58 – 85

ARNO Werkzeughalter Langdrehen – mit Innenkühlung / ARNO tool holders for sliding head lathes – with internal cooling / Porta-utensili ARNO per la tornitura cilindrica - con raffreddamento interno

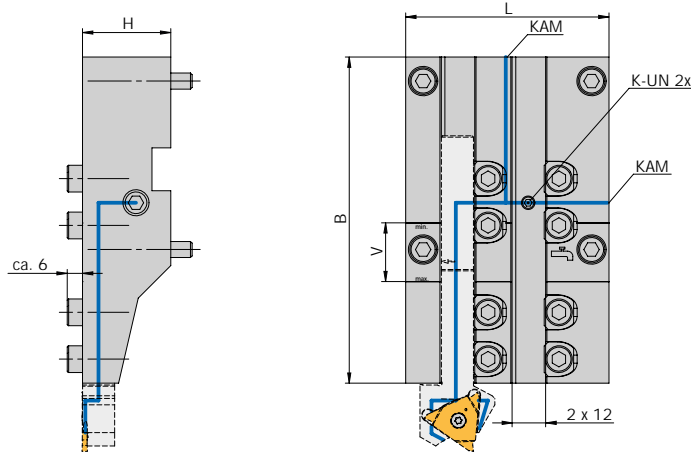

KAM = Kühlmittelanschlussmöglichkeiten
KAM = coolant adapter options
KAM = raccordi del refrigerante

SGS = Sperrgewindestift - bei Bedarf für zwei sperate Druckkammern (Hochdruck)
SGS = locking threaded pin - for two separate pressure chambers (high pressure)
SGS = spina filettata di chiusura - se necessario genera due camere con pressioni separate (alta pressione)

V = In diesem Bereich ist die Kühlmittelversorgung über UN sichergestellt
V = coolant supply is ensured via UN in this range
V = In quest'area l'alimentazione del refrigerante è tramite connessione UN

N NEU/NEW/NUOVO

Trägerwerkzeuge / Holders / Utensili

Bezeichnung Designation Articolo	L	B	H	12 x 12	V	KAM
AWL-571-01-010- IK N	76	122	33	2x	22	G1/8" (2x)

ARNO® SpecialDesign

Hinweis: Auf Anfrage fertigen wir gerne AWL-Schlitten passend zu Ihrem Maschinentyp an.
On request we manufacture AWL heads to fit your machine type.
Su richiesta realizziamo piastre AWL adatti al vostro tipo di macchina.

Ersatzteile / Spare Parts / Ricambi

Trägerwerkzeug Holder Utensile	Spannkeil Clamping wedge Cuneo di bloccaggio	Blindstopfen Dummy plug Tappi ciechi	Verschlusschraube Screw plug Vite forniti	Drehmoment- quergriff Torque wrench T-handle Chiave dinamometrica con impugnatura a T	Sechskantklinge Hexagonal blade Lama esagonale
AWL-571-01-010- IK	AWL-SK111345	GN 749-G1/8-A	AS 0075	T53	T53SW5

! Eine spätere Demontage der Verschlusschraube ist nicht mehr möglich.
Once the screw plug is tightened it can not be removed anymore.
Una volta serrata la vite non sarà più possibile rimuoverla

3 Hinweis: Passende Anschläge finden Sie auf Seite 86 – 89
Remark: For matching fix stops see page 86 – 89
Nota: I fermi compatibili si trovano a pagina 86 – 89

3 Hinweis: Passende Trägerwerkzeuge finden Sie auf Seite 58 – 85
Remark: For matching tool holders see page 58 – 85
Nota: Gli utensili compatibili si trovano a pagina 58 – 85

ARNO Werkzeughalter Langdrehen – mit Innenkühlung / ARNO tool holders for sliding head lathes – with internal cooling / Porta-utensili ARNO per la tornitura cilindrica - con raffreddamento interno

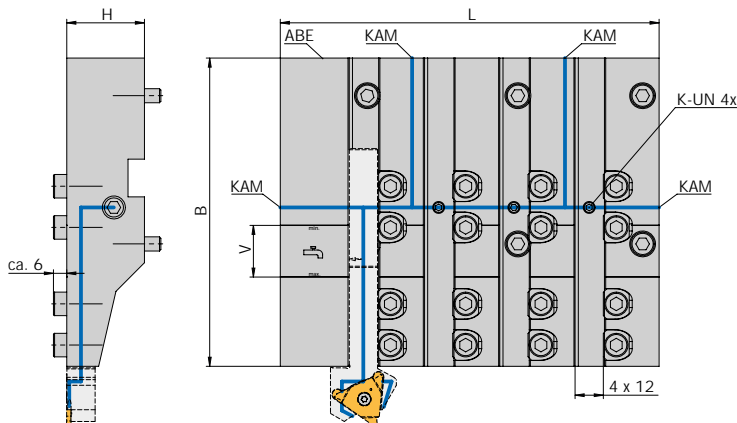

KAM = Kühlmittelanschlussmöglichkeiten

KAM = coolant adapter options

KAM = raccordi del refrigerante

SGS = Sperrgewindestift - bei Bedarf für zwei sperate Druckkammern (Hochdruck)

SGS = locking threaded pin - for two separate pressure chambers (high pressure)

SGS = spina filettata di chiusura - se necessario genera due camere con pressioni separate (alta pressione)

V = In diesem Bereich ist die Kühlmittelversorgung über UN sichergestellt

V = coolant supply is ensured via UN in this range

V = In quest'area l'alimentazione del refrigerante è tramite connessione UN



Trägerwerkzeuge / Holders / Utensili

Bezeichnung Designation Articolo	L	B	H	12 x 12	V	KAM
AWL-571-03-010- IK N	161	131	33	4x	22	G1/8" (4x)

ARNO® SpecialDesign

Hinweis: Auf Anfrage fertigen wir gerne AWL-Schlitten passend zu Ihrem Maschinentyp an.

On request we manufacture AWL heads to fit your machine type.

Su richiesta realizziamo piastre AWL adatti al vostro tipo di macchina.

Ersatzteile / Spare Parts / Ricambi

Trägerwerkzeug Holder Utensile	Spannkeil Clamping wedge Cuneo di bloccaggio	Blindstopfen Dummy plug Tappi ciechi	Verschlusssschraube Screw plug Vite forniti	Kühlmittelanschluss-winklig, fest Coolant connection, angled, fixed Raccordo angolare del refrigerante, fisso	Drehmoment-quergriff Torque wrench T-handle Chiave dinamometrica con impugnatura a T	Sechskantklinge Hexagonal blade Lama esagonale
AWL-571-03-010- IK	AWL-SK111345	GN749-G1/8-A	AS 0075	KA 005	T53	T53SW5



Eine spätere Demontage der Verschlusssschraube ist nicht mehr möglich.

Once the screw plug is tightened it can not be removed anymore.

Una volta serrata la vite non sarà più possibile rimuoverla



Hinweis: Passende Anschläge finden Sie auf Seite 86 – 89

Remark: For matching fix stops see page 86 – 89

Nota: I fermi compatibili si trovano a pagina 86 – 89



Hinweis: Passende Trägerwerkzeuge finden Sie auf Seite 58 – 85

Remark: For matching tool holders see page 58 – 85

Nota: Gli utensili compatibili si trovano a pagina 58 – 85

ARNO Werkzeughalter Langdrehen – mit Innenkühlung / ARNO tool holders for sliding head lathes – with internal cooling / Porta-utensili ARNO per la tornitura cilindrica - con raffreddamento interno

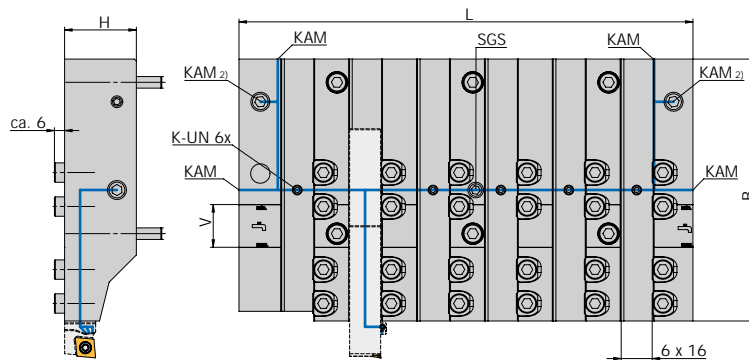

KAM = Kühlmittelanschlussmöglichkeiten
KAM = coolant adapter options
KAM = raccordi del refrigerante

SGS = Sperrgewindestift - bei Bedarf für zwei sperate Druckkammern (Hochdruck)
SGS = locking threaded pin - for two separate pressure chambers (high pressure)
SGS = spina filettata di chiusura - se necessario genera due camere con pressioni separate (alta pressione)

V = In diesem Bereich ist die Kühlmittelversorgung über UN sichergestellt
V = coolant supply is ensured via UN in this range
V = In quest'area l'alimentazione del refrigerante è tramite connessione UN



Trägerwerkzeuge / Holders / Utensili

Bezeichnung Designation Articolo	L	B	H	16 x 16	V	KAM
AWL-670-62-010- IK N	234	135	37	6x	22	G1/8* (6x)

ARNO® SpecialDesign

Hinweis: Auf Anfrage fertigen wir gerne AWL-Schlitten passend zu Ihrem Maschinentyp an.
On request we manufacture AWL heads to fit your machine type.
Su richiesta realizziamo piastre AWL adatti al vostro tipo di macchina.

Ersatzteile / Spare Parts / Ricambi

Trägerwerkzeug Holder Utensile	Spannkeil Clamping wedge Cuneo di bloccaggio	Blindstopfen Dummy plug Tappi ciechi	Verschluss- schraube Screw plug Vite forniti	Kühlmittel- anschluss-winklig, fest Coolant connec- tion, angled, fixed Raccordo angolare del refrigerante, fisso	Sperrgewindestift Locking threaded pin Vite senza testa di arresto	Drehmoment- quergriff Torque wrench T-handle Chiave dinamo- metrica con impugnatura a T	Sechskantklinge Hexagonal blade Lama esagonale
AWL-670-62-010- IK	AWL-SK111345	GN749-G1/8-A	AS 0075	KA 005	AWL-SGSM0825	T53	T53SW5

! Eine spätere Demontage der Verschlusschraube ist nicht mehr möglich.
Once the screw plug is tightened it can not be removed anymore.
Una volta serrata la vite non sarà più possibile rimuoverla

• Hinweis: Passende Anschläge finden Sie auf Seite 86 – 89
Remark: For matching fix stops see page 86 – 89
Nota: I fermi compatibili si trovano a pagina 86 – 89

• Hinweis: Passende Trägerwerkzeuge finden Sie auf Seite 58 – 85
Remark: For matching tool holders see page 58 – 85
Nota: Gli utensili compatibili si trovano a pagina 58 – 85

ARNO Werkzeughalter Langdrehen – mit Innenkühlung / ARNO tool holders for sliding head lathes – with internal cooling / Porta-utensili ARNO per la tornitura cilindrica - con raffreddamento interno

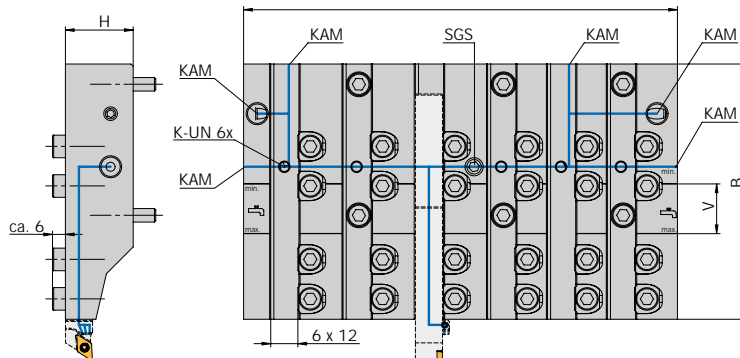

KAM = Kühlmittelanschlussmöglichkeiten

KAM = coolant adapter options

KAM = raccordi del refrigerante

SGS = Sperrgewindestift - bei Bedarf für zwei sperate Druckkammern (Hochdruck)

SGS = locking threaded pin - for two separate pressure chambers (high pressure)

SGS = spina filettata di chiusura - se necessario genera due camere con pressioni separate (alta pressione)

V = In diesem Bereich ist die Kühlmittelversorgung über UN sichergestellt

V = coolant supply is ensured via UN in this range

V = In quest'area l'alimentazione del refrigerante è tramite connessione UN

Trägerwerkzeuge / Holders / Utensili

Bezeichnung Designation Articolo	L	B	H	12 x 12	V	KAM
AWL-680-62-010-1K	192	113	30	6x	22	G1/8" (6x)

ARNO® SpecialDesign

Hinweis: Auf Anfrage fertigen wir gerne AWL-Schlitten passend zu Ihrem Maschinentyp an.

On request we manufacture AWL heads to fit your machine type.

Su richiesta realizziamo piastre AWL adatti al vostro tipo di macchina.

Ersatzteile / Spare Parts / Ricambi

Trägerwerkzeug Holder Utensile	Spannkeil Clamping wedge Cuneo di bloccaggio	Blindstopfen Dummy plug Tappi ciechi	Verschlussschraube Screw plug Vite forniti	Sperrgewindestift Locking threaded pin Vite senza testa di arresto	Drehmomentquergriff Torque wrench T-handle Chiave dinamometrica con impugnatura a T	Sechskantklinge Hexagonal blade Lama esagonale
AWL-680-62-010-1K	AWL-SK111345	GN749-G1/8-A	AS 0075	AWL-SGSM0818	T53	T53SW5

! Eine spätere Demontage der Verschlussschraube ist nicht mehr möglich.

Once the screw plug is tightened it can not be removed anymore.

Una volta serrata la vite non sarà più possibile rimuoverla

! Hinweis: Passende Anschläge finden Sie auf Seite 86 – 89

Remark: For matching fix stops see page 86 – 89

Nota: I fermi compatibili si trovano a pagina 86 – 89

! Hinweis: Passende Trägerwerkzeuge finden Sie auf Seite 58 – 85

Remark: For matching tool holders see page 58 – 85

Nota: Gli utensili compatibili si trovano a pagina 58 – 85

ARNO Werkzeughalter Langdrehen – mit Innenkühlung / ARNO tool holders for sliding head lathes – with internal cooling / Porta-utensili ARNO per la tornitura cilindrica - con raffreddamento interno

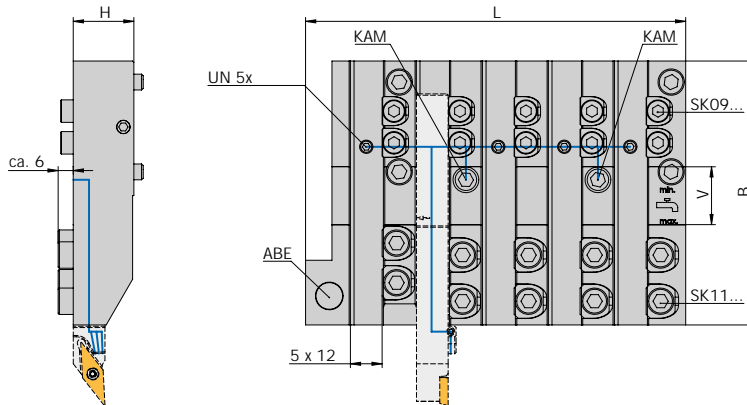

KAM = Kühlmittelanschlussmöglichkeiten

KAM = coolant adapter options

KAM = raccordi del refrigerante

V = In diesem Bereich ist die Kühlmittelversorgung über UN sichergestellt

V = coolant supply is ensured via UN in this range

V = In quest'area l'alimentazione del refrigerante è tramite connessione UN

ABE = Abstechstahlbruchererkennung, Original von Star kann montiert werden

ABE = parting insert rupture detection, Star original can be fitted

ABE = Rilevamento rottura inserto da troncatore, può essere montato ricambio originale Star

N NEU/NEW/NUOVO

Trägerwerkzeuge / Holders / Utensili

Bezeichnung Designation Articolo	L	B	H	12 x 12	V	KAM
AWL-7.079.542- N IK	144	100	23	5x	22	G1/8" (2x)

ARNO® SpecialDesign

Hinweis: Auf Anfrage fertigen wir gerne AWL-Schlitten passend zu Ihrem Maschinentyp an.

On request we manufacture AWL heads to fit your machine type.

Su richiesta realizziamo piastre AWL adatti al vostro tipo di macchina.

Ersatzteile / Spare Parts / Ricambi

Trägerwerkzeug Holder Utensile	Spannkeil Clamping wedge Cuneo di bloccaggio	Blindstopfen Dummy plug Tappi ciechi	Verschlusschraube Screw plug Vite forniti	Kühlmittel-anschluss-winklig, fest Coolant connection, angled, fixed Raccordo angolare del refrigerante, fisso	Drehmoment-quergriff Torque wrench T-handle Chiave dinamometrica con impugnatura a T	Sechskantklinge Hexagonal blade Lama esagonale
AWL-7.079.542- N IK	AWL-SK091145 / AWL-SK111345	GN749-G1/8-A	AS 0075	KA 005	T53	T53SW4 / T53SW5

! Eine spätere Demontage der Verschlusschraube ist nicht mehr möglich.

Once the screw plug is tightened it can not be removed anymore.

Una volta serrata la vite non sarà più possibile rimuoverla

! Hinweis: Passende Anschläge finden Sie auf Seite 86 – 89

Remark: For matching fix stops see page 86 – 89

Nota: I fermi compatibili si trovano a pagina 86 – 89

! Hinweis: Passende Trägerwerkzeuge finden Sie auf Seite 58 – 85

Remark: For matching tool holders see page 58 – 85

Nota: Gli utensili compatibili si trovano a pagina 58 – 85

ARNO Werkzeughalter Langdrehen – mit Innenkühlung / ARNO tool holders for sliding head lathes – with internal cooling / Porta-utensili ARNO per la tornitura cilindrica - con raffreddamento interno

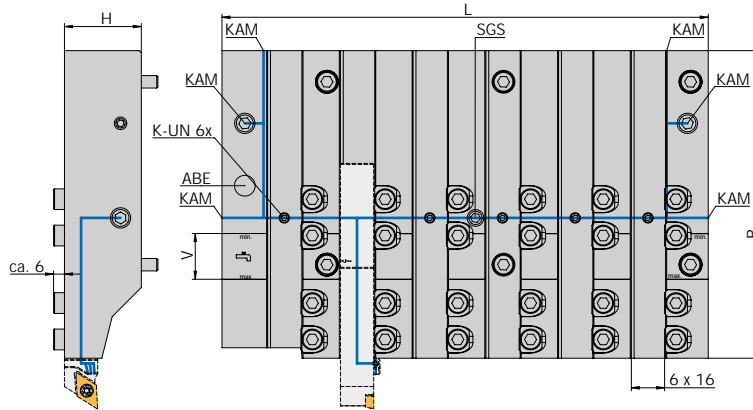

KAM = Kühlmittelanschlussmöglichkeiten

KAM = coolant adapter options

KAM = raccordi del refrigerante

SGS = Sperrgewindestift - bei Bedarf für zwei sperate Druckkammern (Hochdruck)

SGS = locking threaded pin - for two separate pressure chambers (high pressure)

SGS = spina filettata di chiusura - se necessario genera due camere con pressioni separate (alta pressione)

V = In diesem Bereich ist die Kühlmittelversorgung über UN sichergestellt

V = coolant supply is ensured via UN in this range

V = In quest'area l'alimentazione del refrigerante è tramite connessione UN

ABE = Abstechstahlbruchererkennung, Original von Star kann montiert werden

ABE = parting insert rupture detection, Star original can be fitted

ABE = Rilevamento rottura inserto da troncatura, può essere montato ricambio originale Star



Trägerwerkzeuge / Holders / Utensili

Bezeichnung Designation Articolo	L	B	H	16 x 16	V	KAM
AWL-PO-00170-1K N	234	148	37	6x	22	G1/8" (6x)

ARNO® SpecialDesign

Hinweis: Auf Anfrage fertigen wir gerne AWL-Schlitten passend zu Ihrem Maschinentyp an.

On request we manufacture AWL heads to fit your machine type.

Su richiesta realizziamo piastre AWL adatti al vostro tipo di macchina.

Ersatzteile / Spare Parts / Ricambi

Trägerwerkzeug Holder Utensile	Spannkeil Clamping wedge Cuneo di bloccaggio	Blindstopfen Dummy plug Tappi ciechi	Verschluss-schraube Screw plug Vite forniti	Kühlmittel-anschluss-winklig, fest Coolant connection, angled, fixed Raccordo angolare del refrigerante, fisso	Sperrgewindestift Locking threaded pin Vite senza testa di arresto	Drehmoment-quergriff Torque wrench T-handle Chiave dinamometrica con impugnatura a T	Sechskantklinge Hexagonal blade Lama esagonale
AWL-PO-00170-1K	AWL-SK111345	GN749-G1/8-A	AS 0075	KA 005	AWL-SGSM0825	T53	T53SW5

! Eine spätere Demontage der Verschluss-schraube ist nicht mehr möglich.

Once the screw plug is tightened it can not be removed anymore.

Una volta serrata la vite non sarà più possibile rimuoverla

! Hinweis: Passende Anschläge finden Sie auf Seite 86 – 89

Remark: For matching fix stops see page 86 – 89

Nota: I fermi compatibili si trovano a pagina 86 – 89

! Hinweis: Passende Trägerwerkzeuge finden Sie auf Seite 58 – 85

Remark: For matching tool holders see page 58 – 85

Nota: Gli utensili compatibili si trovano a pagina 58 – 85

ARNO Werkzeughalter Langdrehen – mit Innenkühlung / ARNO tool holders for sliding head lathes – with internal cooling / Porta-utensili ARNO per la tornitura cilindrica - con raffreddamento interno

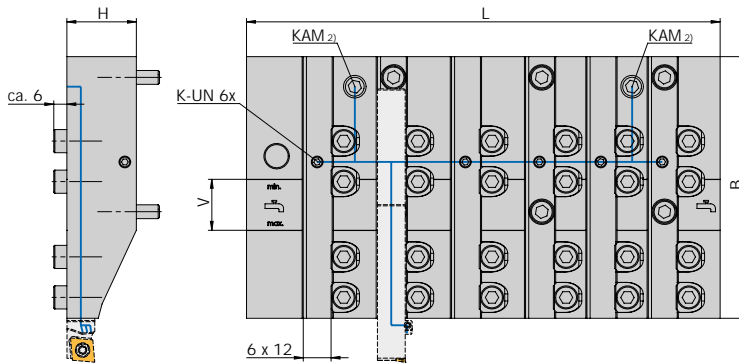

KAM = Kühlmittelanschlussmöglichkeiten

KAM = coolant adapter options

KAM = raccordi del refrigerante

V = In diesem Bereich ist die Kühlmittelversorgung über UN sichergestellt

V = coolant supply is ensured via UN in this range

V = In quest'area l'alimentazione del refrigerante è tramite connessione UN

Trägerwerkzeuge / Holders / Utensili

Bezeichnung Designation Articolo	L	B	H	12 x 12	V	KAM
AWL-PO-17140-IK	204,5	113	30	6x	22	G1/8" (2x)

ARNO® SpecialDesign

Hinweis: Auf Anfrage fertigen wir gerne AWL-Schlitten passend zu Ihrem Maschinentyp an.

On request we manufacture AWL heads to fit your machine type.

Su richiesta realizziamo piastre AWL adatti al vostro tipo di macchina.

Ersatzteile / Spare Parts / Ricambi

Trägerwerkzeug Holder Utensile	Spannkeil Clamping wedge Cuneo di bloccaggio	Blindstopfen Dummy plug Tappi ciechi	Verschlusschraube Screw plug Vite forniti	Kühlmittel-anschluss-winklig, fest Coolant connection, angled, fixed Raccordo angolare del refrigerante, fisso	Drehmoment-quergriff Torque wrench T-handle Chiave dinamometrica con impugnatura a T	Sechskantklinge Hexagonal blade Lama esagonale
AWL-PO-17140-IK	AWL-SK111345	GN749-G1/8-A	AS 0075	KA 005	T53	T53SW5



Eine spätere Demontage der Verschlusschraube ist nicht mehr möglich.

Once the screw plug is tightened it can not be removed anymore.

Una volta serrata la vite non sarà più possibile rimuoverla



Hinweis: Passende Anschläge finden Sie auf Seite 86 – 89

Remark: For matching fix stops see page 86 – 89

Nota: I fermi compatibili si trovano a pagina 86 – 89



Hinweis: Passende Trägerwerkzeuge finden Sie auf Seite 58 – 85

Remark: For matching tool holders see page 58 – 85

Nota: Gli utensili compatibili si trovano a pagina 58 – 85

M9A 0009 – Montagehinweis / Assembly instructions / Schema di montaggio

**Allgemein:**

Zur Montage des Werkzeughalters sind sechs Zylinderkopfschrauben M6x25 beige gestellt. Durch zwei Führungsbolzen auf der Rückseite wird die Position des Werkzeughalters auf der Maschine bestimmt.

Kühlung:

Am Werkzeughalter stehen fünf Anschlussmöglichkeiten (Pos.1) zur Kühlmittelversorgung bereit. Nicht benötigte Anschlussmöglichkeiten können mit den beige gestellten Verschlusschrauben AS 0075 verschlossen werden. Alternativ können auch Blindstopfen GN749-G178-A verwendet werden. Bei Bedarf können zwei separate Kühlmittelkreisläufe generiert werden. Durch Einschrauben des Sperrgewindestifts (Pos.2) bewirken Sie eine Aufteilung der Kühlmittelversorgung von T1,T2 und T3 ,T4 ,T5 innerhalb des Werkzeughalters. Voraussetzung: Zwei separate Druckausgänge an der Kühlmittelpumpe um beide Kammern mit Kühlmittel versorgen zu können. Zusätzlich kann jede einzelne Kammer mit einem Gewindestift ISO4026-M5x5-A2 (Pos.3) verschlossen bzw. geöffnet werden. Die Kühlmittelversorgung ist innerhalb des Verstellweges V sichergestellt.

Montage und Handling der AFC-Klemmhalter und AFC-Anschläge

Die Anschläge AHA...1212...AFC werden mit den oberen zwei Spannkeilen (Pos.4) montiert. Hinweis: Grundsätzlich ist bei der Verwendung von IKZ die Anschlagausführung UN (AHA-1212-UN...-AFC) zu verwenden. Dieser sollte nach Möglichkeit nicht mehr demontiert werden, da sonst die Wechselgenauigkeit und Positionierung des AFC-Klemmhalter nicht mehr gewährleistet ist. Die AFC-Klemmhalter mit Schneidplatte werden in die Nut eingesetzt und gegen den AFC-Anschlag geschoben und danach mit den unteren zwei Spannkeilen (Pos.5) gespannt und gewechselt.

Sonstiges

Bitte verwenden Sie zum Spannen der Spannkeile AWL-SK111345 den Drehmomentquergriff T53 mit der Sechskantklinge T53SW5

“General:

Six cylinder-head screws M6x25 are enclosed to fit the tool holder. Two guide bolts at the rear determine the tool holder position on the machine.

Cooling:

The tool holder has five connection options (Pos.1) for coolant supply. The connection options which are not required can be closed off using the enclosed screw plugs AS 0075. Alternatively, dummy plugs GN749-G178-A can be used. Two separate coolant circuits can be generated as required. The coolant supply of T1, T2 and T3, T4, T5 can be separated within the tool holder by screwing in the locking threaded pin (Pos.2). Requirement: Two separate pressure outlets on the coolant pump to supply the two chambers with coolant. In addition, each chamber can be closed off or opened by using a threaded pin ISO4026-M5x5-A2 (Pos.3). This ensures coolant supply within the adjustment path V.

Fitting and handling the AFC tool holder and AFC fixed stops

The fix stops AHA...1212...AFC are fitted using the top two clamping wedges (Pos.4). Remark: In all cases, use the fixed stop design UN (AHA-1212-UN...-AFC) when IKZ is fitted. It should no longer be removed as far as possible otherwise the precision and positioning of the AFC tool holder is no longer ensured when a change takes place. Fit the AFC tool holder and insert in the groove and slide them against the AFC fix stop. Then clamp and change with the bottom two clamping wedges (Pos.5).

Other remarks

Our recommendation: Please use the torque wrench T-handle T53 and the hexagonal blade T53SW5 to clamp the clamping wedge AWL-SK111345“

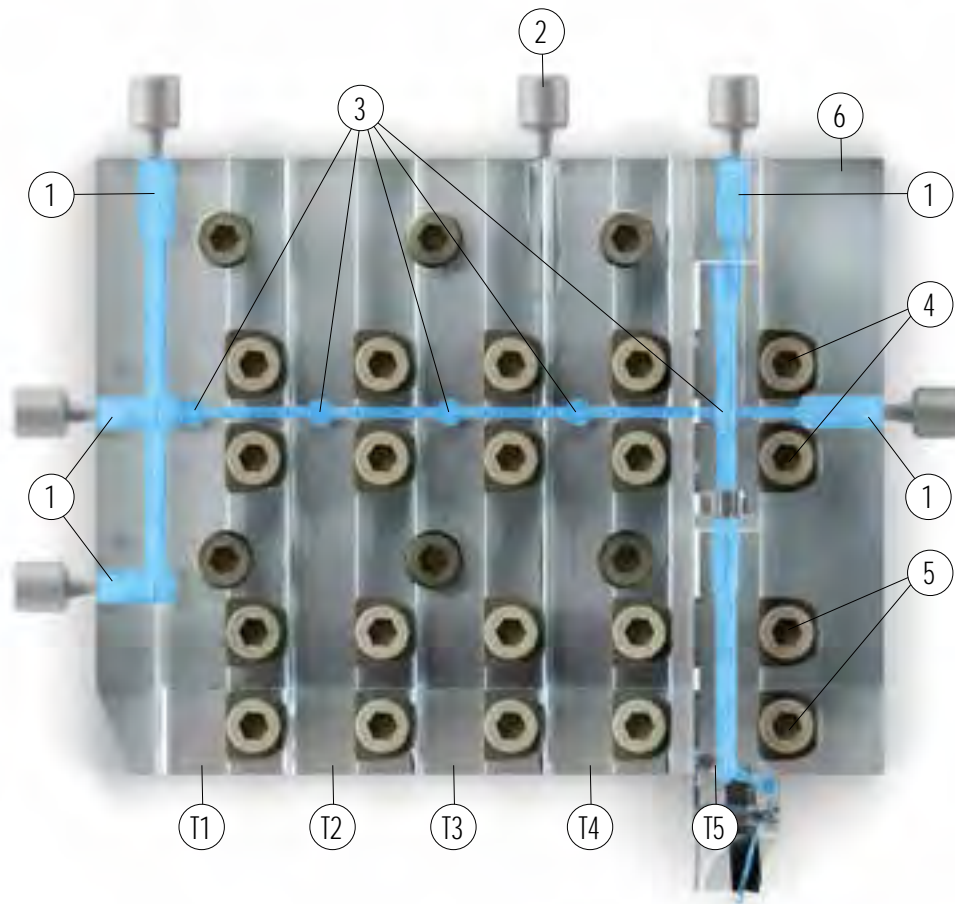

Anzugsmoment der Spannkeile
AWL-SK111345 = 9 Nm
Tightening torque for clamping wedge
AWL-SK111345 = 9 Nm
Coppia di serraggio dei cunei d'arresto
AWL-SK111345 = 9 Nm

*Informazioni generali:

Per il montaggio del portautensili sono fornite sei viti a testa cilindrica M6x25. I due bulloni di guida sul lato posteriore servono a determinare la posizione del portautensili sulla macchina.

Raffreddamento:

Sul portautensili sono disponibili cinque raccordi (Pos. 1) per l'alimentazione del liquido refrigerante. I raccordi non necessari possono essere chiusi con i tappi a vite forniti AS 0075. In alternativa possono essere utilizzati anche dei tappi ciechi GN749-G178-A. Se necessari possono essere generati due circuiti separati del liquido refrigerante. Avvitando la spina filettata di arresto (Pos. 2) è possibile suddividere l'alimentazione del refrigerante tra T1, T2 e T3, T4, T5 all'interno del portautensili. Premessa: È necessario che siano presenti due uscite della pressione separate sulla pompa del liquido refrigerante per poter alimentare con il liquido refrigerante entrambe le camere. Inoltre ogni singola camera può essere chiusa o aperta con una vite senza testa ISO4026-M5x5-A2 (Pos. 3). L'alimentazione del liquido refrigerante è garantita all'interno della corsa a V.

Montaggio e movimentazione degli adattatori AFC e dei fermi AFC

I fermi AHA...1212...AFC vengono montati con i due cunei d'arresto superiori (Pos. 4). Nota: Generalmente quando si utilizza l'alimentazione interna del refrigerante è necessario utilizzare la versione UN del finecorsa (AHA-1212-UN...-AFC). Il finecorsa, se possibile, non dovrebbe essere smontato perché altrimenti la precisione di cambio e il posizionamento dell'adattatore AFC non è più garantita. Gli adattatori AFC con inserto vengono inseriti nella sede e spinti verso il finecorsa AFC e quindi vengono serrati e cambiati con i due cunei d'arresto inferiori (Pos. 5).

Altre informazioni

Per il serraggio dei cunei d'arresto AWL-SK111345 utilizzare la chiave dinamometrica con impugnatura a T T53 con punta esagonale T53SW5"

Langdrehen mit Innenkühlung *Auto lathes with through tool coolant* Fantina mobile con adduzione interna



Die meisten modernen Langdrehautomaten verfügen über Hochdruckpumpen, sodass die ARNO® Langdrehhalter auf diesen Maschinen beste Zerspanungsergebnisse ermöglichen.

Durch die zielgerichtete Zuführung des Kühlmittels in die Zerspanungszone (zwischen der Wendeschneidplatte und dem abfließenden Span) wird die auftretende Hitze effektiv reduziert. Die Späne werden weniger heiß und brechen dadurch leichter.

Most modern sliding head auto lathes have a high pressure pump installed, and therefore the ARNO® through tool coolant auto lathe holders would offer maximum performance.

The precise coolant flow directly to the cutting zone (between the insert and the swarf) effectively reduces the heat and thereby making chip breaking easier.

La maggior parte dei torni automatici moderni sono dotati di pompe ad alta pressione, questo fa sì che i prodotti ARNO® specifici per questa tipologia di macchine raggiungano migliori risultati di taglio.

Con la adduzione mirata del refrigerante alla zona di taglio (tra l'inserto ed il truciolo) la temperatura sviluppata viene notevolmente ridotta. I trucioli risultano quindi meno caldi migliorando la rottura degli stessi.

Fakten / Features / Caratteristiche

- Erhöhung der Prozesssicherheit
- Längere Standzeiten – Standzeiterhöhung um bis zu 100% möglich
- Kürzere Bearbeitungszeit – die Schnittgeschwindigkeit kann bei der Bearbeitung erhöht werden (Steigerung der Produktivität)
- Verbesserte Spankontrolle – auch bei den meisten Problemwerkstoffen
- Sehr effektive Abkühlung der Schneidkante – Beschichtungen, die empfindlich auf Hitzeschwankungen reagieren, werden geschützt
- Sicherer und stabiler Prozess
- *Increase of productivity*
- *Better tool life – possibly up to 100% better*
- *Shorten production time – cutting speeds can be increased*
- *Improved swarf control – even on problem materials*
- *Efficient coolant of the insert cutting edge, protecting coatings which can be deteriorate due temperature changes*
- *Secure and reliable machining*
- *Maggiore affidabilità di lavorazione*
- *Maggiore durata – incremento della vita inserto possibile fino al 100%*
- *Tempi ciclo ridotti – le velocità di taglio possono essere aumentate migliorando il tempo ciclo ed aumentando la produttività*
- *Migliore controllo truciolo su materiali problematici da lavorare*
- *Efficace raffreddamento del tagliente – riduce lo shock termico*
- *Ciclo stabile ed affidabile*

SCACR Anstellwinkel / Approach angle / Angolo di attacco: 90,5°

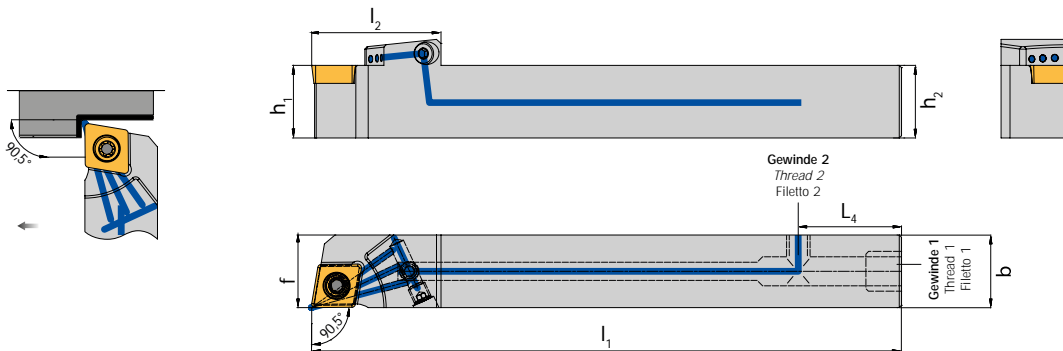

Rechte Ausführung abgebildet
Right-hand execution shown
Versione destra in figura

Klemhalter mit Innenkühlung von der Seite

Ausführung SG. – Das Gewinde 2 ist gegenüber der Schneide

Tool holder with through tool coolant access from the side
Design SG. – Thread 2 is on the opposite side of the cutting edge

Steli con adduzione interna laterale

Versione SG. – Filettatura 2 sul lato opposto l'inserto

Bezeichnung Designation Articolo	h_1 / h_2	b	l_1	l_2	L_4	f	Gewinde 1 Thread 1 Filetto 1	Gewinde 2 Thread 2 Filetto 2	Wendeschneidplatte Insert Inserto
SCACR 1212 X06-AN-IK-S1G	12	12	130	21,0	20	12	M8x1	M8x1	CC.. 0602...
SCACR 1212 X09-AN-IK-S1G	12	12	130	21,0	20	12	M8x1	M8x1	CC.. 09T3...
SCACR 1616 X09-AN-IK-S1G	16	16	130	21,0	20	16	M8x1	M8x1	CC.. 09T3...
SCACR 1212 X06-AN-IK-S2G	12	12	130	21,0	20	12	M8x1	G 1/8"	CC.. 0602...
SCACR 1212 X09-AN-IK-S2G	12	12	130	21,0	20	12	M8x1	G 1/8"	CC.. 09T3...
SCACR 1616 X09-AN-IK-S2G	16	16	130	21,0	20	16	M8x1	G 1/8"	CC.. 09T3...

Eine Anfrage der Klemhaltervarianten
finden Sie auf Seite 141

An overview of varieties can be found
on page 141

Per diverse tipologie di raccordo e
posizione utilizzare modulo a pag 141

Ersatzteile / Spare parts / Ricambi

Halter Holder Stelo	Schraube Screw Vite	Schlüssel Key Chiave	Gewindestift Thread pin Grano	Schlüssel Key Chiave
SCACR...X06-AN-IK-...	SS 1751	KS 1751	DIN 913 - M4 x 4	KP 3421
SCACR...X09-AN-IK-...	SS 1111	KS 1111	DIN 913 - M4 x 4	KP 3421

SCLCR Anstellwinkel / Approach angle / Angolo di attacco: 95°

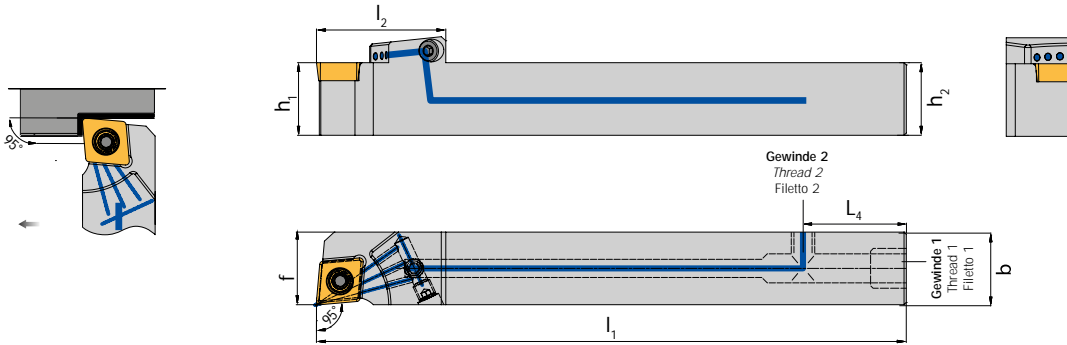

Rechte Ausführung abgebildet
Right-hand execution shown
Versione destra in figura

Klemhalter mit Innenkühlung von der Seite

Ausführung SG. – Das Gewinde 2 ist gegenüber der Schneide

Tool holder with through tool coolant access from the side
Design SG. – Thread 2 is on the opposite side of the cutting edge

Steli con adduzione interna laterale

Versione SG. – Filettatura 2 sul lato opposto l'inserto

Bezeichnung Designation Articolo	h_1 / h_2	b	l_1	l_2	L_4	f	Gewinde 1 Thread 1 Filetto 1	Gewinde 2 Thread 2 Filetto 2	Wendeschneidplatte Insert Inserto
SCLCR 1212 X06-AN-IK-S1G	12	12	130	21,0	20	12	M8x1	M8x1	CC.. 0602...
SCLCR 1212 X09-AN-IK-S1G	12	12	130	21,0	20	12	M8x1	M8x1	CC.. 09T3...
SCLCR 1616 X09-AN-IK-S1G	16	16	130	21,0	20	16	M8x1	M8x1	CC.. 09T3...
SCLCR 1212 X06-AN-IK-S2G	12	12	130	21,0	20	12	M8x1	G 1/8"	CC.. 0602...
SCLCR 1212 X09-AN-IK-S2G	12	12	130	21,0	20	12	M8x1	G 1/8"	CC.. 09T3...
SCLCR 1616 X09-AN-IK-S2G	16	16	130	21,0	20	16	M8x1	G 1/8"	CC.. 09T3...

Eine Anfrage der Klemhaltervarianten
finden Sie auf Seite 141

An overview of varieties can be found
on page 141

Per diverse tipologie di raccordo e
posizione utilizzare modulo a pag 141

Ersatzteile / Spare parts / Ricambi

Halter Holder Stelo	Schraube Screw Vite	Schlüssel Key Chiave	Gewindestift Thread pin Grano	Schlüssel Key Chiave
SCLCR...X06-AN-IK-...	SS 1751	KS 1751	DIN 913 - M4x4	KP 3421
SCLCR...X09-AN-IK-...	SS 1111	KS 1111	DIN 913 - M4x4	KP 3421

SDACR Anstellwinkel / Approach angle / Angolo di attacco: 90,5°

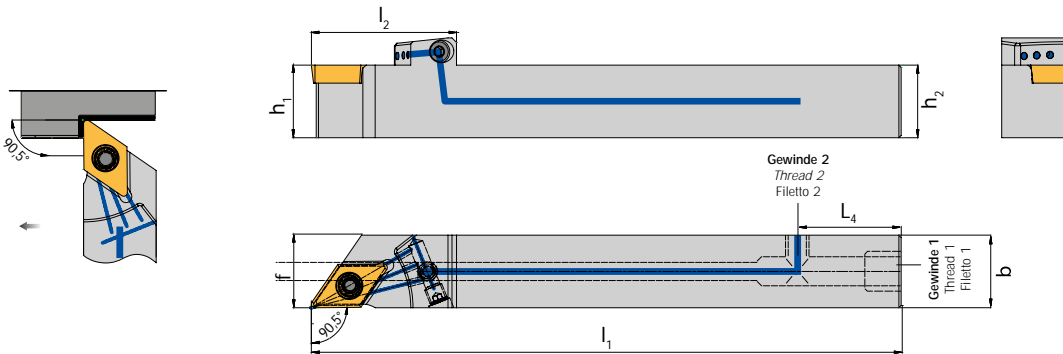

Rechte Ausführung abgebildet
Right-hand execution shown
Versione destra in figura

Klemmhalter mit Innenkühlung von der Seite

Ausführung SG. – Das Gewinde 2 ist gegenüber der Schneide

Tool holder with through tool coolant access from the side
Design SG. – Thread 2 is on the opposite side of the cutting edge

Steli con adduzione interna laterale

Versione SG. – Filettatura 2 sul lato opposto l'inserto

Bezeichnung Designation Articolo	h_1 / h_2	b	l_1	l_2	L_4	f	Gewinde 1 Thread 1 Filetto 1	Gewinde 2 Thread 2 Filetto 2	Wendeschneidplatte Insert Inserto
SDACR 1212 X07-AN-IK-S1G	12	12	130	22,0	20	12	M8x1	M8x1	DC.. 0702...
SDACR 1212 X11-AN-IK-S1G	12	12	130	27,5	20	12	M8x1	M8x1	DC.. 11T3...
SDACR 1616 X11-AN-IK-S1G	16	16	130	27,5	20	16	M8x1	M8x1	DC.. 11T3...
SDACR 1212 X07-AN-IK-S2G	12	12	130	22,0	20	12	M8x1	G 1/8"	DC.. 0702...
SDACR 1212 X11-AN-IK-S2G	12	12	130	27,5	20	12	M8x1	G 1/8"	DC.. 11T3...
SDACR 1616 X11-AN-IK-S2G	16	16	130	27,5	20	16	M8x1	G 1/8"	DC.. 11T3...

Eine Anfrage der Klemmhaltervarianten
finden Sie auf Seite 141

An overview of varieties can be found
on page 141

Per diverse tipologie di raccordo e
posizione utilizzare modulo a pag 141

Ersatzteile / Spare parts / Ricambi

Halter Holder Stelo	Schraube Screw Vite	Schlüssel Key Chiave	Gewindestift Thread pin Grano	Schlüssel Key Chiave
SDACR...X07-AN-IK-...	SS 1751	KS 1751	DIN 913 - M4x4	KP 3421
SDACR...X11-AN-IK-...	SS 1111	KS 1111	DIN 913 - M4x4	KP 3421

SDJCR Anstellwinkel / Approach angle / Angolo di attacco: 93°

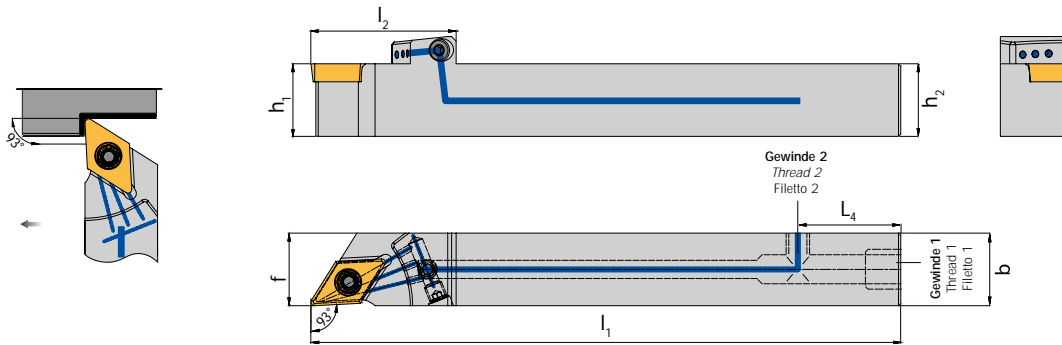

Rechte Ausführung abgebildet
Right-hand execution shown
Versione destra in figura

Klemhalter mit Innenkühlung von der Seite

Ausführung SG. – Das Gewinde 2 ist gegenüber der Schneide

Tool holder with through tool coolant access from the side
Design SG. – Thread 2 is on the opposite side of the cutting edge

Steli con adduzione interna laterale

Versione SG. – Filettatura 2 sul lato opposto l'inserto

Bezeichnung Designation Articolo	h_1 / h_2	b	l_1	l_2	L_4	f	Gewinde 1 Thread 1 Filetto 1	Gewinde 2 Thread 2 Filetto 2	Wendeschneidplatte Insert Inserto
SDJCR 1212 X07-AN-IK-S1G	12	12	130	21,0	20	12	M8x1	M8x1	DC.. 0702...
SDJCR 1212 X11-AN-IK-S1G	12	12	130	27,5	20	12	M8x1	M8x1	DC.. 11T3...
SDJCR 1616 X11-AN-IK-S1G	16	16	130	27,5	20	16	M8x1	M8x1	DC.. 11T3...
SDJCR 1212 X07-AN-IK-S2G	12	12	130	21,0	20	12	M8x1	G 1/8"	DC.. 0702...
SDJCR 1212 X11-AN-IK-S2G	12	12	130	27,5	20	12	M8x1	G 1/8"	DC.. 11T3...
SDJCR 1616 X11-AN-IK-S2G	16	16	130	27,5	20	16	M8x1	G 1/8"	DC.. 11T3...

Eine Anfrage der Klemhaltervarianten
finden Sie auf Seite 141

An overview of varieties can be found
on page 141

Per diverse tipologie di raccordo e
posizione utilizzare modulo a pag 141

Ersatzteile / Spare parts / Ricambi

Halter Holder Stelo	Schraube Screw Vite	Schlüssel Key Chiave	Gewindestift Thread pin Grano	Schlüssel Key Chiave
SDJCR...X07-AN-IK-...	SS 1751	KS 1751	DIN 913 - M4x4	KP 3421
SDJCR...X11-AN-IK-...	SS 1111	KS 1111	DIN 913 - M4x4	KP 3421

SDNCN Anstellwinkel / Approach angle / Angolo di attacco: 62,5°

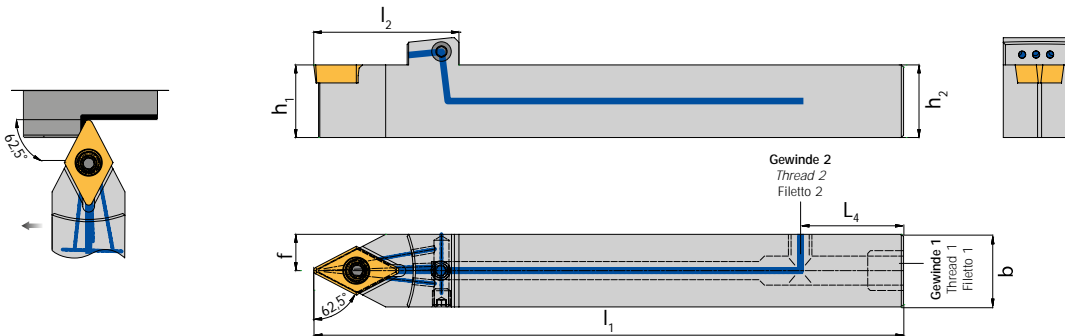

Klemmhalter mit Innenkühlung von der Seite

Ausführung SG. – Das Gewinde 2 ist gegenüber der Schneide

Tool holder with through tool coolant access from the side
Design SG. – Thread 2 is on the opposite side of the cutting edge

Steli con adduzione interna laterale

Versione SG. – Filettatura 2 sul lato opposto l'inserto

Bezeichnung Designation Articolo	h_1 / h_2	b	l_1	l_2	L_4	f	Gewinde 1 Thread 1 Filetto 1	Gewinde 2 Thread 2 Filetto 2	Wendeschneidplatte Insert Inserto
SDNCN 1212 X07-AN-IK-S1G	12	12	130	22,0	20	6	M8x1	M8x1	DC.. 0702...
SDNCN 1212 X11-AN-IK-S1G	12	12	130	27,5	20	6	M8x1	M8x1	DC.. 11T3...
SDNCN 1616 X11-AN-IK-S1G	16	16	130	27,5	20	8	M8x1	M8x1	DC.. 11T3...
SDNCN 1212 X07-AN-IK-S2G	12	12	130	22,0	20	6	M8x1	G 1/8"	DC.. 0702...
SDNCN 1212 X11-AN-IK-S2G	12	12	130	27,5	20	6	M8x1	G 1/8"	DC.. 11T3...
SDNCN 1616 X11-AN-IK-S2G	16	16	130	27,5	20	8	M8x1	G 1/8"	DC.. 11T3...

Eine Anfrage der Klemmhaltervarianten
finden Sie auf Seite 141

An overview of varieties can be found
on page 141

Per diverse tipologie di raccordo e
posizione utilizzare modulo a pag 141

Ersatzteile / Spare parts / Ricambi

Halter Holder Stelo	Schraube Screw Vite	Schlüssel Key Chiave	Gewindestift Thread pin Grano	Schlüssel Key Chiave
SDNCN...X07-AN-IK-...	SS 1751	KS 1751	DIN 913 - M4x4	KP 3421
SDNCN...X11-AN-IK-...	SS 1111	KS 1111	DIN 913 - M4x4	KP 3421

SVACR Anstellwinkel / Approach angle / Angolo di attacco: 90,5°

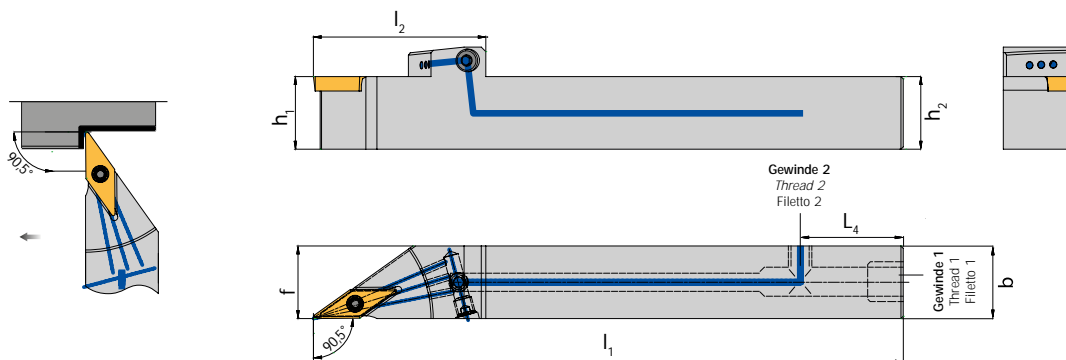

Rechte Ausführung abgebildet
Right-hand execution shown
Versione destra in figura

Klemhalter mit Innenkühlung von der Seite

Ausführung SG. – Das Gewinde 2 ist gegenüber der Schneide

Tool holder with through tool coolant access from the side
Design SG. – Thread 2 is on the opposite side of the cutting edge

Steli con adduzione interna laterale

Versione SG. – Filettatura 2 sul lato opposto l'inserto

Bezeichnung Designation Articolo	h_1 / h_2	b	l_1	l_2	L_4	f	Gewinde 1 Thread 1 Filetto 1	Gewinde 2 Thread 2 Filetto 2	Wendeschneidplatte Insert Inserto
SVACR 1212 X11-AN-IK-S1G	12	12	130	28,0	20	12	M8x1	M8x1	VC.. 1103...
SVACR 1212 X16-AN-IK-S1G	12	12	130	38,0	20	12	M8x1	M8x1	VC.. 1604...
SVACR 1616 X11-AN-IK-S1G	16	16	130	28,0	20	16	M8x1	M8x1	VC.. 1103...
SVACR 1616 X16-AN-IK-S1G	16	16	130	38,0	20	16	M8x1	M8x1	VC.. 1604...
SVACR 1212 X11-AN-IK-S2G	12	12	130	28,0	20	12	M8x1	G 1/8"	VC.. 1103...
SVACR 1212 X16-AN-IK-S2G	12	12	130	38,0	20	12	M8x1	G 1/8"	VC.. 1604...
SVACR 1616 X11-AN-IK-S2G	16	16	130	28,0	20	16	M8x1	G 1/8"	VC.. 1103...
SVACR 1616 X16-AN-IK-S2G	16	16	130	38,0	20	16	M8x1	G 1/8"	VC.. 1604...

Eine Anfrage der Klemhaltervarianten
finden Sie auf Seite 141

An overview of varieties can be found
on page 141

Per diverse tipologie di raccordo e
posizione utilizzare modulo a pag 141

Ersatzteile / Spare parts / Ricambi

Halter Holder Stelo	Schraube Screw Vite	Schlüssel Key Chiave	Gewindestift Thread pin Grano	Schlüssel Key Chiave
SVACR...X11-AN-IK-...	SS 1751	KS 1751	DIN 913 - M4x4	KP 3421
SVACR...X16-AN-IK-...	SS 1111	KS 1111	DIN 913 - M4x4	KP 3421

SVJCR Anstellwinkel / Approach angle / Angolo di attacco: 93°

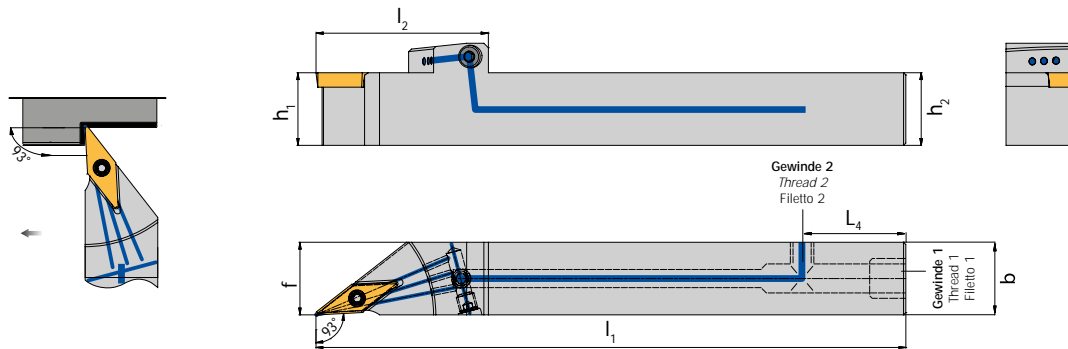

Rechte Ausführung abgebildet
Right-hand execution shown
Versione destra in figura

Klemmhalter mit Innenkühlung von der Seite

Ausführung SG. – Das Gewinde 2 ist gegenüber der Schneide

Tool holder with through tool coolant access from the side
Design SG. – Thread 2 is on the opposite side of the cutting edge

Steli con adduzione interna laterale

Versione SG. – Filettatura 2 sul lato opposto l'inserto

Bezeichnung Designation Articolo	h_1 / h_2	b	l_1	l_2	L_4	f	Gewinde 1 Thread 1 Filetto 1	Gewinde 2 Thread 2 Filetto 2	Wendeschneidplatte Insert Inserto
SVJCR 1212 X11-AN-IK-S1G	12	12	130	28,0	20	12	M8x1	M8x1	VC.. 1103...
SVJCR 1212 X13-AN-IK-S1G	12	12	130	34,0	20	12	M8x1	M8x1	VC.. 1303...
SVJCR 1212 X16-AN-IK-S1G	12	12	130	38,0	20	12	M8x1	M8x1	VC.. 1604...
SVJCR 1616 X11-AN-IK-S1G	16	16	130	28,0	20	16	M8x1	M8x1	VC.. 1103...
SVJCR 1616 X13-AN-IK-S1G	16	16	130	34,0	20	16	M8x1	M8x1	VC.. 1303...
SVJCR 1616 X16-AN-IK-S1G	16	16	130	38,0	20	16	M8x1	M8x1	VC.. 1604...
SVJCR 1212 X11-AN-IK-S2G	12	12	130	28,0	20	12	M8x1	G 1/8"	VC.. 1103...
SVJCR 1212 X13-AN-IK-S2G	12	12	130	34,0	20	12	M8x1	G 1/8"	VC.. 1303...
SVJCR 1212 X16-AN-IK-S2G	12	12	130	38,0	20	12	M8x1	G 1/8"	VC.. 1604...
SVJCR 1616 X11-AN-IK-S2G	16	16	130	28,0	20	16	M8x1	G 1/8"	VC.. 1103...
SVJCR 1616 X13-AN-IK-S2G	16	16	130	34,0	20	16	M8x1	G 1/8"	VC.. 1303...
SVJCR 1616 X16-AN-IK-S2G	16	16	130	38,0	20	16	M8x1	G 1/8"	VC.. 1604...

Eine Anfrage der Klemmhaltervarianten
finden Sie auf Seite 141

An overview of varieties can be found
on page 141

Per diverse tipologie di raccordo e
posizione utilizzare modulo a pag 141

Ersatzteile / Spare parts / Ricambi

Halter Holder Stelo	Schraube Screw Vite	Schlüssel Key Chiave	Gewindestift Thread pin Grano	Schlüssel Key Chiave
SVJCR...X11-AN-IK-...	SS 1751	KS 1751	DIN 913 - M4x4	KP 3421
SVJCR...X13-AN-IK-...	SS 8831	KS 1751	DIN 913 - M4x4	KP 3421
SVJCR...X16-AN-IK-...	SS 1111	KS 1111	DIN 913 - M4x4	KP 3421

SVVCN Anstellwinkel / Approach angle / Angolo di attacco: 72,5°

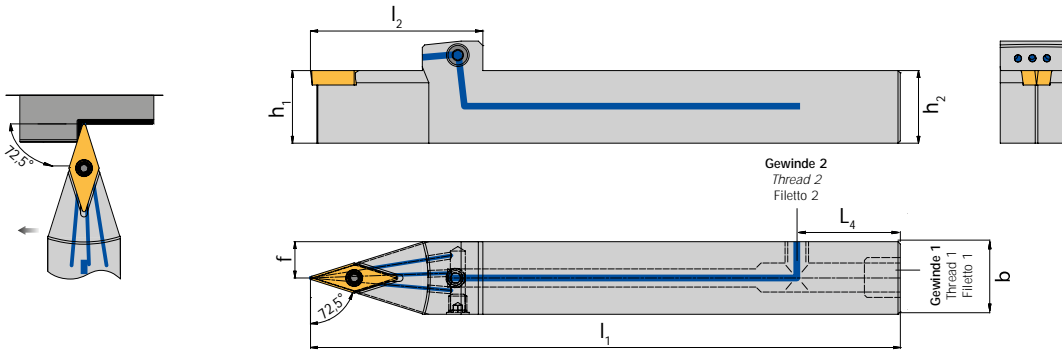

Klemmhalter mit Innenkühlung von der Seite

Ausführung SG. – Das Gewinde 2 ist gegenüber der Schneide

Tool holder with through tool coolant access from the side
Design SG. – Thread 2 is on the opposite side of the cutting edge

Steli con adduzione interna laterale

Versione SG. – Filettatura 2 sul lato opposto l'inserto

Bezeichnung Designation Articolo	h_1 / h_2	b	l_1	l_2	L_4	f	Gewinde 1 Thread 1 Filetto 1	Gewinde 2 Thread 2 Filetto 2	Wendeschneidplatte Insert Inserto
SVVCN 1212 X11-AN-IK-S1G	12	12	130	28,0	20	6	M8x1	M8x1	VC.. 1103...
SVVCN 1212 X16-AN-IK-S1G	12	12	130	38,0	20	6	M8x1	M8x1	VC.. 1604...
SVVCN 1616 X11-AN-IK-S1G	16	16	130	28,0	20	8	M8x1	M8x1	VC.. 1103...
SVVCN 1616 X16-AN-IK-S1G	16	16	130	38,0	20	8	M8x1	M8x1	VC.. 1604...
SVVCN 1212 X11-AN-IK-S2G	12	12	130	28,0	20	6	M8x1	G 1/8"	VC.. 1103...
SVVCN 1212 X16-AN-IK-S2G	12	12	130	38,0	20	6	M8x1	G 1/8"	VC.. 1604...
SVVCN 1616 X11-AN-IK-S2G	16	16	130	28,0	20	8	M8x1	G 1/8"	VC.. 1103...
SVVCN 1616 X16-AN-IK-S2G	16	16	130	38,0	20	8	M8x1	G 1/8"	VC.. 1604...

Eine Anfrage der Klemmhaltervarianten
finden Sie auf Seite 141

An overview of varieties can be found
on page 141

Per diverse tipologie di raccordo e
posizione utilizzare modulo a pag 141

Ersatzteile / Spare parts / Ricambi

Halter Holder Stelo	Schraube Screw Vite	Schlüssel Key Chiave	Gewindestift Thread pin Grano	Schlüssel Key Chiave
SVVCN...X11-AN-IK-...	SS 1751	KS 1751	DIN 913 - M4x4	KP 3421
SVVCN...X16-AN-IK-...	SS 1111	KS 1111	DIN 913 - M4x4	KP 3421

Zubehör / Accessories / Accessori

Bezeichnung Designation Articolo		A	B
KA 001	Kühlmittelanschluss – gerade Coolant supply – straight	M8x1	Ø 6 mm
KA 002	Raccordo – dritto	1/8"	Ø 6 mm
KA 004	Kühlmittelanschluss – winklig, fest Coolant supply – angled and fixed	M8x1	Ø 6 mm
KA 005	Raccordo – angolato	1/8"	Ø 6 mm
KA 006	Schwenkverschraubung Swivelling screw-fitting	M8x1	Ø 6 mm
KA 007	Raccordo – orientabile	1/8"	Ø 6 mm

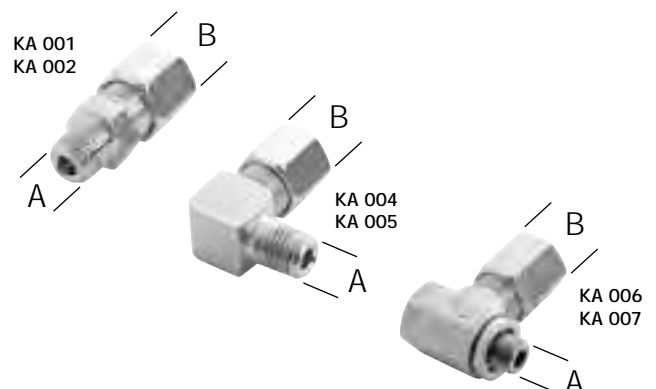

Anfrage Innenkühlung Klemmhalter -AN-IK

Enquiry through tool coolant access tool holder -AN-IK

Modulo di richiesta per adduzione interna steli -AN-IK



Klemmhalter mit Innenkühlung von hinten

Tool holder with through tool coolant access from the back

Steli con adduzione interna raccordo posteriore

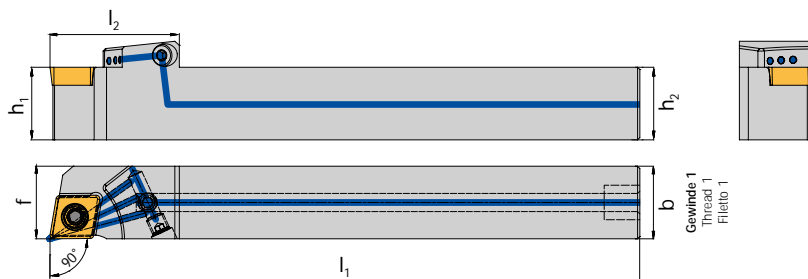

Aus Halter From holder Da utensile	Gewinde 1 Thread 1 Filetto 1	l_1
..... 1212 -AN-IK		
..... 1616 -AN-IK		

Klemmhalter mit Innenkühlung von der Seite

Tool holder with through tool coolant access from the side

Steli con adduzione interna raccordo laterale

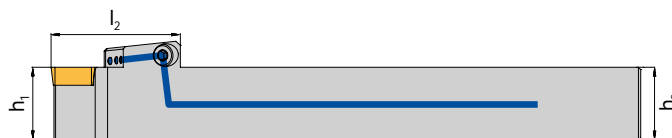

Standardausführung/

Basic version/

Versione standard

l_1

..... 1212 -AN-IK	130
..... 1616 -AN-IK	130

Ausführung S. – Das Gewinde 2 ist auf der gleichen Seite wie die Schneide

Design S. – Thread 2 is on the same side as the cutting edge

Versione S. – Filettatura 2 sul medesimo lato dell'inserto

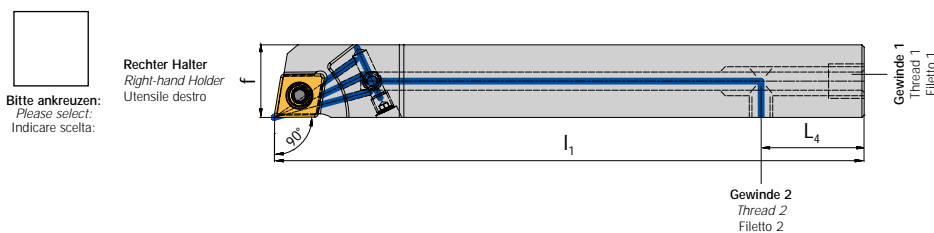

Bitte ankreuzen:
Please select:
Indicare scelta:

Rechter Halter
Right-hand Holder
Utensile destro

Ausführung SG. – Das Gewinde 2 ist gegenüber der Schneide

Design SG. – Thread 2 is on the opposite side of the cutting edge

Versione SG. – Filettatura 2 sul lato opposto l'inserto

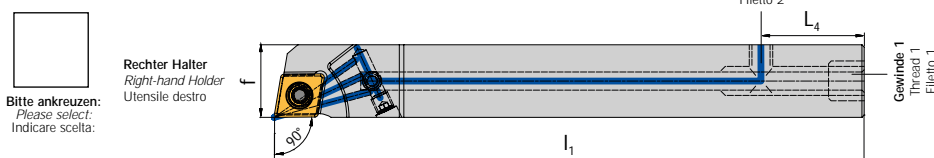

Bitte ankreuzen:
Please select:
Indicare scelta:

Rechter Halter
Right-hand Holder
Utensile destro

Aus Halter From holder Da utensile	Gewinde 1 Thread 1 Filetto 1	Gewinde 2 Thread 2 Filetto 2	L_4	l_1
..... 1212 -AN-IK				
..... 1616 -AN-IK				

Basishalter W519 0002 / W519 0003 / W519 0004 / W519 0194 / W519 0195 / W519 0197 - mit Innenkühlung



Basic holder W519 0002 / W519 0003 / W519 0004 / W519 0194 / W519 0195 / W519 0197- with internal coolant

Steli base W519 0002 / W519 0003 / W519 0004 / W519 0194 / W519 0195 / W519 0197- con refrigerazione interna

Klemmhalter mit IK-H-MS - speziell für INDEX/TRAUB mit MS22 Schnittstelle

Tool holder with IK-H-MS - specially for INDEX/TRAUB with MS 22 interface

Steli con bloccaggio con IK-H-MS - specifici per INDEX/TRAUB con l'interfaccia MS 22

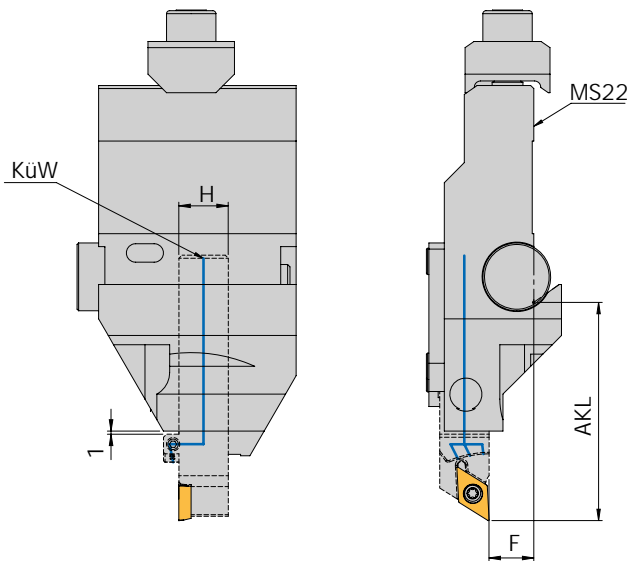

Aufnahme W519 0003 mit Klemmhalter SDJCR 1616X11-IK-H2-MS abgebildet
Attachment W519 0003 shown with tool holder SDJCR 1616X11-IK-H2-MS
Attacco W519 0003 con stelo con bloccaggio SDJCR 1616X11-IK-H2-MS in figura

KuW = Kühlmittelanschluss über Winkelstück
KuW = Coolant adapter with elbow
KuW = Raccordo del refrigerante tramite raccordo a gomito

Trägerwerkzeug / Holder / Utensile

Bezeichnung Designation Articolo	H _{schaft}	Basishalter Basic holder Steli base W519 0002		Basishalter Basic holder Steli base W519 0003		Basishalter Basic holder Steli base W519 0004		Basishalter Basic holder Steli base W519 0194		Basishalter Basic holder Steli base W519 0195		Basishalter Basic holder Steli base W519 0197	
		AKL	F	AKL	F	AKL	F	AKL	F	AKL	F	AKL	F
AL 16-3-R-IK-H2-MS	16	64,5	29,8	64,5	15,2	88,0	15,7	88,0	14,2	89,0	28,8	68,5	12,3
SCLCR 1616X09-IK-H2-MS	16	64,0	30,5	64,0	14,5	87,5	15,0	87,5	13,5	88,5	29,5	69,0	13,0
SDJCR 1616X11-IK-H2-MS	16	71,0	30,5	71,0	14,5	94,5	15,0	94,5	13,5	95,5	29,5	76,0	13,0
SVJCR 1616X11-IK-H2-MS	16	71,0	30,5	71,0	14,5	94,5	15,0	94,5	13,5	95,9	29,5	76,0	13,0

- Basishalter sind über den Maschinenhersteller erhältlich!
- Basic holders are available from the machine manufacturers.
- I supporti di base sono disponibili presso il produttore delle macchine!

Maße AKL und F sind für andere Basishalter auf Anfrage verfügbar. Eine optimale Kühlmittelübergabe kann bei anderen Basishaltern nicht garantiert werden.

Overhang (AKL) and F dimensions are available for other basic holders on request. Perfect coolant transfer cannot be guaranteed on other basic holders.

Le misure AKL e F sono disponibili a richiesta per altri supporti di base. Per gli altri supporti di base non è possibile garantire un passaggio ottimale del liquido refrigerante.

SCLCR Anstellwinkel / Approach angle / Angolo di attacco: 95°



Klemmhalter mit IK-H-MS - speziell für INDEX/TRAUB TNL18 / TNL20 / TNL32

Tool holder with IK-H-MS - specially for INDEX/TRAUB TNL18 / TNL20 / TNL32

Steli con bloccaggio con IK-H-MS - specifici per INDEX/TRAUB TNL18 / TNL20 / TNL32

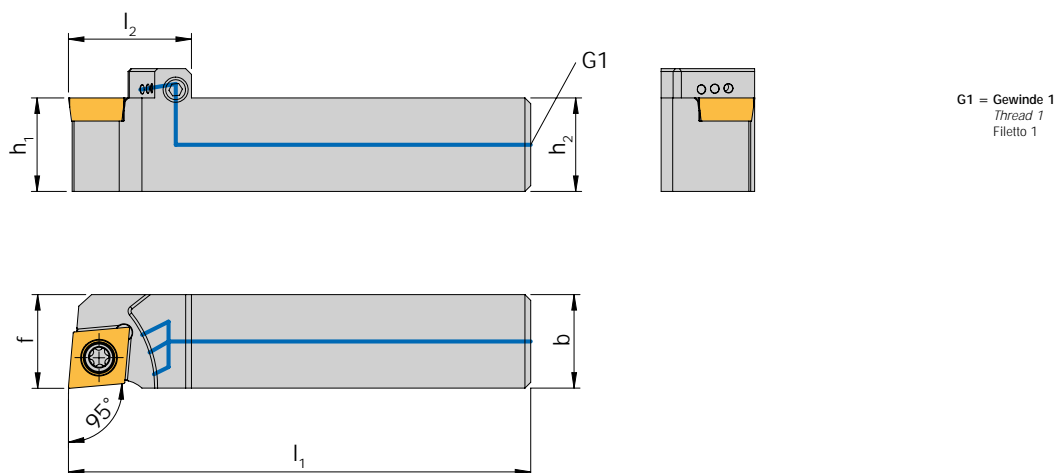

Trägerwerkzeug / Holder / Utensile

Bezeichnung Designation Articolo	h_1 / h_2	b	l_1	l_2	f	Gewinde 1 Thread 1 Filetto 1	Schneideinsatz Insert Inserto
SCLCR 1616X09-IK-H2-MS	16	16	79	21	16	G 1/8"	CC.. 09T3...

Für das F-Maß im eingebauten Zustand, siehe Anwendungshinweis Basishalter

Diese Klemmhalter passen auf folgende Halter von INDEX/TRAUB: W519 0002 / W519 0003 / W519 0004 / W519 0194 / W519 0195 / W519 0197.

For the F dimension when installed, see the basic holder application reference.

These tool holders fit on the following basic holders from INDEX/TRAUB: W519 0002 / W519 0003 / W519 0004 / W519 0194 / W519 0195 / W519 0197.

Per la dimensione F quando montati, si vedano le note tecniche per gli steli base

Questi steli con bloccaggio sono adatti ai seguenti steli di INDEX/TRAUB: W519 0002 / W519 0003 / W519 0004 / W519 0194 / W519 0195 / W519 0197.

Ersatzteile / Spare parts / Ricambi

Trägerwerkzeug Holder Utensile	Schraube Screw Vite	Schlüssel Key Chiave
SCLCR 1616X09-IK-H2-MS	SS 1111	KS 1111

SDJCR Anstellwinkel / Approach angle / Angolo di attacco: 93°



Klemmhalter mit IK-H-MS - speziell für INDEX/TRAUB TNL18 / TNL20 / TNL32

Tool holder with IK-H-MS - specially for INDEX/TRAUB TNL18 / TNL20 / TNL32

Steli con bloccaggio con IK-H-MS - specifici per INDEX/TRAUB TNL18 / TNL20 / TNL32

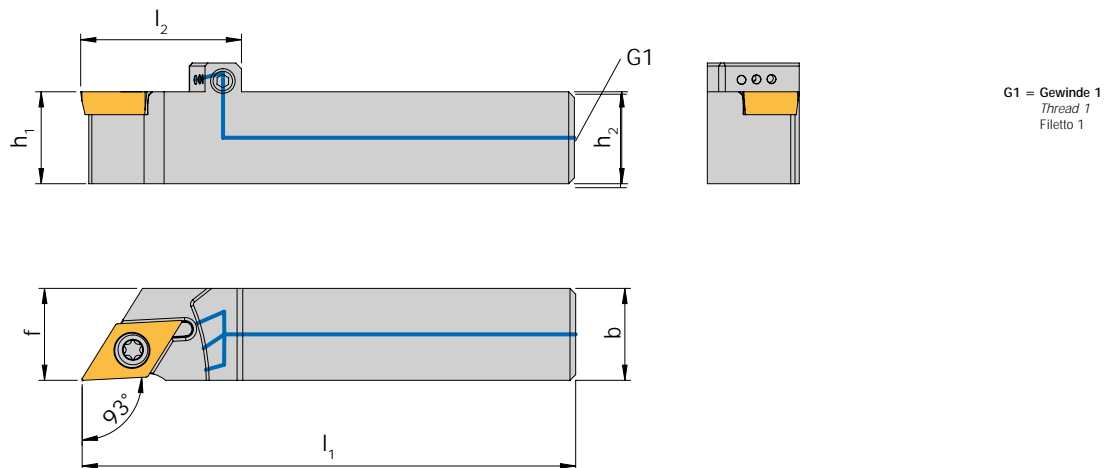

Trägerwerkzeug / Holder / Utensile

Bezeichnung Designation Articolo	h_1 / h_2	b	l_1	l_2	f	Gewinde 1 Thread 1 Filetto 1	Schneideinsatz Insert Inserto
SDJCR 1616X11-IK-H2-MS	16	16	86	28	16	G 1/8"	DC.. 11T3...

Für das F-Maß im eingebauten Zustand, siehe Anwendungshinweis Basishalter

Diese Klemmhalter passen auf folgende Halter von INDEX/TRAUB: W519 0002 / W519 0003 / W519 0004 / W519 0194 / W519 0195 / W519 0197.

For the F dimension when installed, see the basic holder application reference.

These tool holders fit on the following basic holders from INDEX/TRAUB: W519 0002 / W519 0003 / W519 0004 / W519 0194 / W519 0195 / W519 0197.

Per la dimensione F quando montati, si vedano le note tecniche per gli steli base

Questi steli con bloccaggio sono adatti ai seguenti steli di INDEX/TRAUB: W519 0002 / W519 0003 / W519 0004 / W519 0194 / W519 0195 / W519 0197.

Ersatzteile / Spare parts / Ricambi

Trägerwerkzeug Holder Utensile	Schraube Screw Vite	Schlüssel Key Chiave
SDJCR 1616X11-IK-H2-MS	SS 1111	KS 1111

SVJCR Anstellwinkel / Approach angle / Angolo di attacco: 93°



Klemmhalter mit IK-H-MS - speziell für INDEX/TRAUB TNL18 / TNL20 / TNL32

Tool holder with IK-H-MS - specially for INDEX/TRAUB TNL18 / TNL20 / TNL32

Steli con bloccaggio con IK-H-MS - specifici per INDEX/TRAUB TNL18 / TNL20 / TNL32

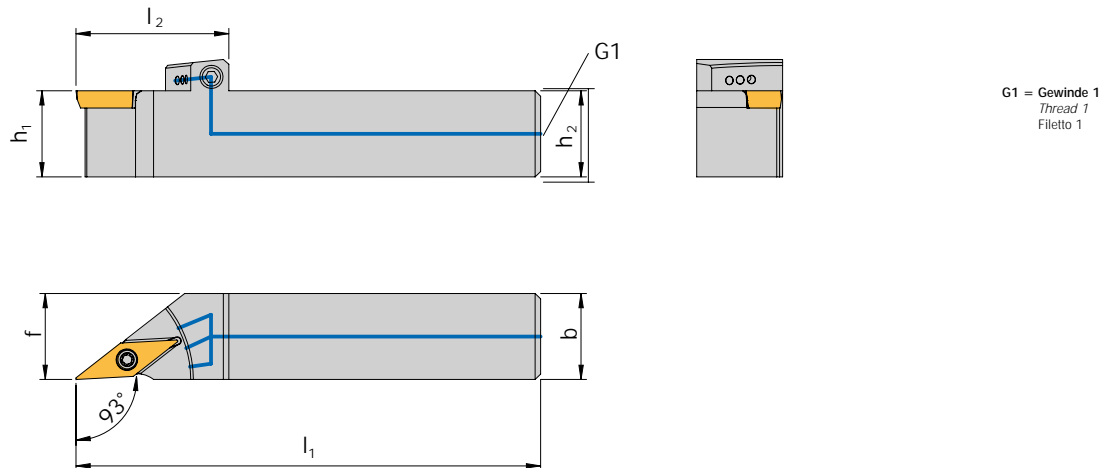

Trägerwerkzeug / Holder / Utensile

Bezeichnung Designation Articolo	h_1 / h_2	b	l_1	l_2	f	Gewinde 1 Thread 1 Filetto 1	Schneideinsatz Insert Inserto
SVJCR 1616X11-IK-H2-MS	16	16	86	28	16	G 1/8"	VC.. 1103...

Für das F-Maß im eingebauten Zustand, siehe Anwendungshinweis Basishalter

Diese Klemmhalter passen auf folgende Halter von INDEX/TRAUB: W519 0002 / W519 0003 / W519 0004 / W519 0194 / W519 0195 / W519 0197.

For the F dimension when installed, see the basic holder application reference.

These tool holders fit on the following basic holders from INDEX/TRAUB: W519 0002 / W519 0003 / W519 0004 / W519 0194 / W519 0195 / W519 0197.

Per la dimensione F quando montati, si vedano le note tecniche per gli steli base

Questi steli con bloccaggio sono adatti ai seguenti steli di INDEX/TRAUB: W519 0002 / W519 0003 / W519 0004 / W519 0194 / W519 0195 / W519 0197.

Ersatzteile / Spare parts / Ricambi

Trägerwerkzeug Holder Utensile	Schraube Screw Vite	Schlüssel Key Chiave
SVJCR 1616X11-IK-H2-MS	SS 1751	KS 1751

Außengewinde – Ausführung Standard

External thread - standard design

Filettatura esterna – Versione standard



Klemmhalter mit IK-H-MS - speziell für INDEX/TRAUB mit MS22 Schnittstelle

Tool holder with IK-H-MS - specially for INDEX/TRAUB with MS 22 interface

Steli con bloccaggio con IK-H-MS - specifici per INDEX/TRAUB con l'interfaccia MS 22

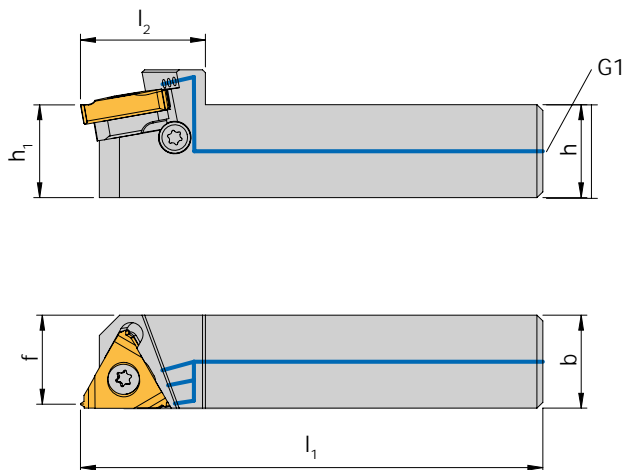

G1 = Gewinde 1
Thread 1
Filetto 1

Trägerwerkzeug / Holder / Utensile

Bezeichnung Designation Articolo	$h = h_1 = b$	f	l_1	l_2	Gewinde 1 Thread 1 Filetto 1	Schneideinsatz Insert Inserto
AL16-3-R-IK-H2-MS	16	15,3	77,5	21,5	G 1/8"	16ER...

Für das F-Maß im eingebauten Zustand, siehe Anwendungshinweis Basishalter

Diese Klemmhalter passen auf folgende Halter von INDEX/TRAUB: W519 0002 / W519 0003 / W519 0004 / W519 0194 / W519 0195 / W519 0197.

For the F dimension when installed, see the basic holder application reference.

These tool holders fit on the following basic holders from INDEX/TRAUB: W519 0002 / W519 0003 / W519 0004 / W519 0194 / W519 0195 / W519 0197.

Per la dimensione F quando montati, si vedano le note tecniche per gli steli base

Questi steli con bloccaggio sono adatti ai seguenti steli di INDEX/TRAUB: W519 0002 / W519 0003 / W519 0004 / W519 0194 / W519 0195 / W519 0197.

Ersatzteile / Spare parts / Ricambi

Trägerwerkzeug Holder Utensile	Klemmschraube Clamping screw Vite di fissaggio	Schraube + Scheibe für Unterlegplatte Screw + washer for support pad Vite + bussola per supporto	Schlüssel Key Chiave	Unterlegplatte R Support pad R Supporto R
AL16-3-R-IK-H2-MS	SA3T	SY3T	KS 2510	YE3

SDUC R/L Anstellwinkel / Approach angle / Angolo di attacco: 93°

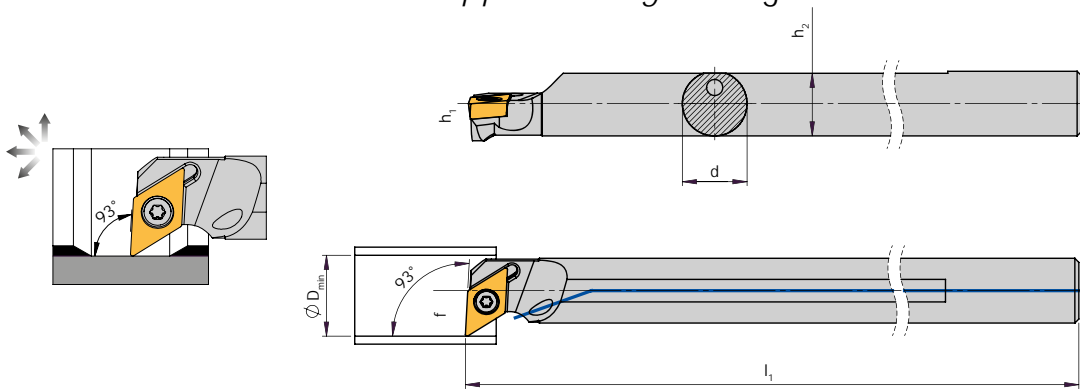

Rechte Ausführung abgebildet
Right-hand execution shown
Versione destra in figura

Bohrstangen – Stahlschaft mit innerer Kühlmittelzufuhr

Boring bar – Steel shank with through tool coolant

Bareno – Stelo in acciaio con foro refrigerante

Bezeichnung Designation Articolo	d	h ₁	h ₂	l ₁	f	a	D _{min}	Wendeschneidplatte Insert Inserto
A16M SDUC R/L 11	16,0	8,0	15,5	150	11	2,9	20,0	DC.. 11T3...

Ersatzteile / Spare parts / Ricambi

Für Bohrstange For boring bar Per bareno	Schraube Screw Vite	Schlüssel Key Chiave	Sortiment Spare part set Set ricambi
..16.. SDUC.. 11	SS 1114	KS 1114	S 1114

SVJC R/L Anstellwinkel / Approach angle / Angolo di attacco: 142°

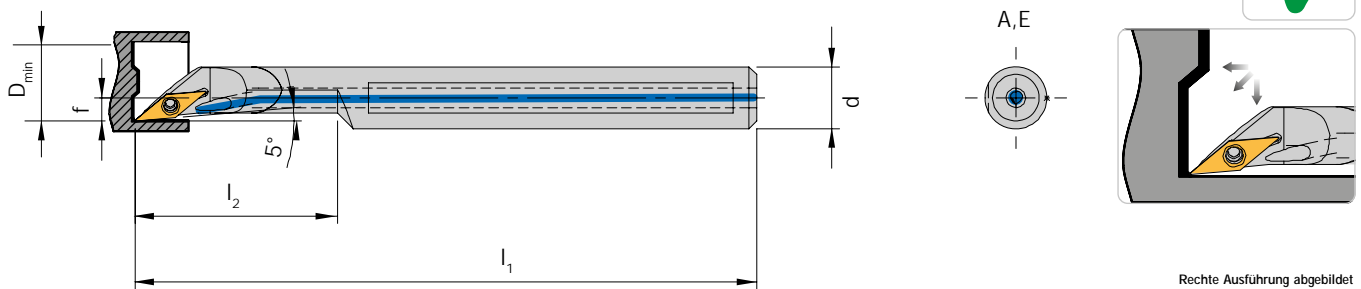

Rechte Ausführung abgebildet
Right-hand execution shown
Versione destra in figura

Bohrstangen – Stahlschaft mit innerer Kühlmittelzufuhr

Boring bar – Steel shank with through tool coolant

Bareno – Stelo in acciaio con foro refrigerante

Bezeichnung Designation Articolo	d	l ₁	l ₂	f	D _{min}	Wendeschneidplatte Insert Inserto
A08F SVJCR 05	8	80	15	1,0	8	VC.. 0501...
A08F SVJCL 05	8	80	15	1,0	8	VC.. 0501...
A10K SVJCR 07	10	125	18	1,5	13	VC.. 0702...
A10K SVJCL 07	10	125	18	1,5	13	VC.. 0702...
A12L SVJCR 07	12	140	18	1,5	13	VC.. 0702...
A12L SVJCL 07	12	140	18	1,5	13	VC.. 0702...

Bohrstangen – Vollhartmetallschaft mit innerer Kühlmittelzufuhr

Boring bar – Carbide shank with through tool coolant

Bareno – Stelo in metallo duro integrale con foro refrigerante

Bezeichnung Designation Articolo	d	l ₁	l ₂	f	D _{min}	Wendeschneidplatte Insert Inserto
E08F SVJCR 05	8	80	15	1,0	8	VC.. 0501...
E08F SVJCL 05	8	80	15	1,0	8	VC.. 0501...
E10K SVJCR 07	10	125	18	1,5	13	VC.. 0702...
E10K SVJCL 07	10	125	18	1,5	13	VC.. 0702...
E12M SVJCR 07	12	140	18	1,5	13	VC.. 0702...
E12M SVJCL 07	12	140	18	1,5	13	VC.. 0702...

Ersatzteile / Spare parts / Ricambi

Für Bohrstange For boring bar Per bareno	Schraube Screw Vite	Schlüssel Key Chiave
..08.. SVJC.. 07	VT1605	BT05
..10-12.. SVJC.. 07	VT20	BT06

SVLC R/L Anstellwinkel / Approach angle / Angolo di attacco: 95°

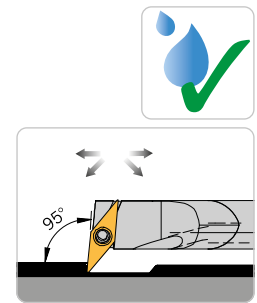
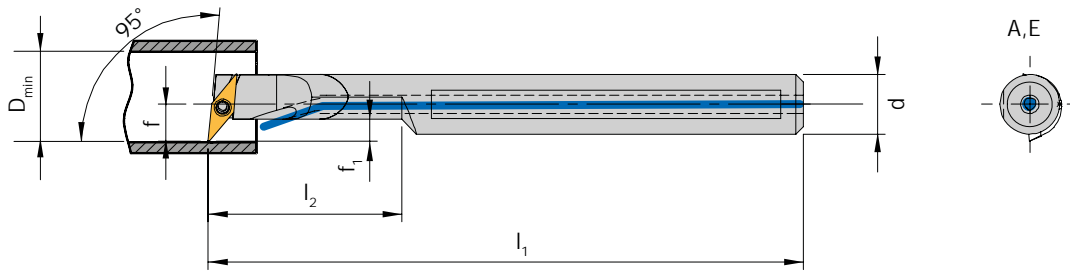

Rechte Ausführung abgebildet
Right-hand execution shown
Versione destra in figura

Bohrstangen – Stahlschaft mit innerer Kühlmittelzufuhr

Boring bar – Steel shank with through tool coolant

Bareno – Stelo in acciaio con foro refrigerante

Bezeichnung Designation Articolo	d	l ₁	l ₂	f	f ₁	D _{min}	Wendeschneidplatte Insert Inserto
A08F SVLCR 05	8	80	15	5	3	9,2	VC.. 0501...
A08F SVLCL 05	8	80	15	5	3	9,2	VC.. 0501...

Bohrstangen – Vollhartmetallschaft mit innerer Kühlmittelzufuhr

Boring bar – Carbide shank with through tool coolant

Bareno – Stelo in metallo duro integrale con foro refrigerante

Bezeichnung Designation Articolo	d	l ₁	l ₂	f	f ₁	D _{min}	Wendeschneidplatte Insert Inserto
E08F SVLCR 05	8	80	26	5	3	9,2	VC.. 0501...
E08F SVLCL 05	8	80	26	5	3	9,2	VC.. 0501...

Ersatzteile / Spare parts / Ricambi

Für Bohrstange For boring bar Per bareno	Schraube Screw Vite	Schlüssel Key Chiave
..08.. SVLC.. 05	VT1605	BT05

SVVC R/L Anstellwinkel / Approach angle / Angolo di attacco: 72,5°

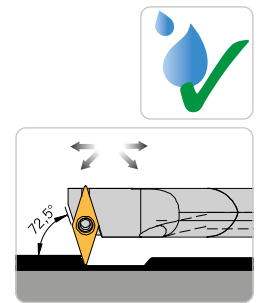
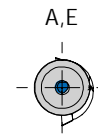
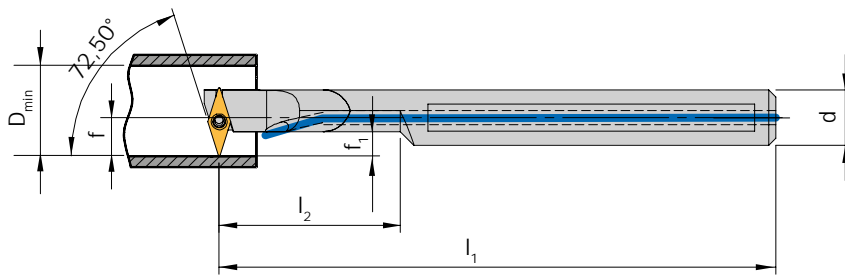

Rechte Ausführung abgebildet
Right-hand execution shown
Versione destra in figura

Bohrstangen – Stahlschaft mit innerer Kühlmittelzufuhr

Boring bar – Steel shank with through tool coolant

Bareno – Stelo in acciaio con foro refrigerante

Bezeichnung Designation Articolo	d	l ₁	l ₂	f	f ₁	D _{min}	Wendeschneidplatte Insert Inserto
A08F SVVCR 05	8	80	15	5,5	3,5	9,7	VC.. 0501...
A08F SVVCL 05	8	80	15	5,5	3,5	9,7	VC.. 0501...

Bohrstangen – Vollhartmetallschaft mit innerer Kühlmittelzufuhr

Boring bar – Carbide shank with through tool coolant

Bareno – Stelo in metallo duro integrale con foro refrigerante

Bezeichnung Designation Articolo	d	l ₁	l ₂	f	f ₁	D _{min}	Wendeschneidplatte Insert Inserto
E08F SVVCR 05	8	80	26	5,5	3,5	9,7	VC.. 0501...
E08F SVVCL 05	8	80	26	5,5	3,5	9,7	VC.. 0501...

Ersatzteile / Spare parts / Ricambi

Für Bohrstange For boring bar Per bareno	Schraube Screw Vite	Schlüssel Key Chiave
..08.. SVVC.. 05	VT1605	BT05

SVXC R/L Anstellwinkel / Approach angle / Angolo di attacco: 113°

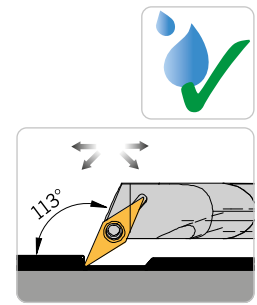
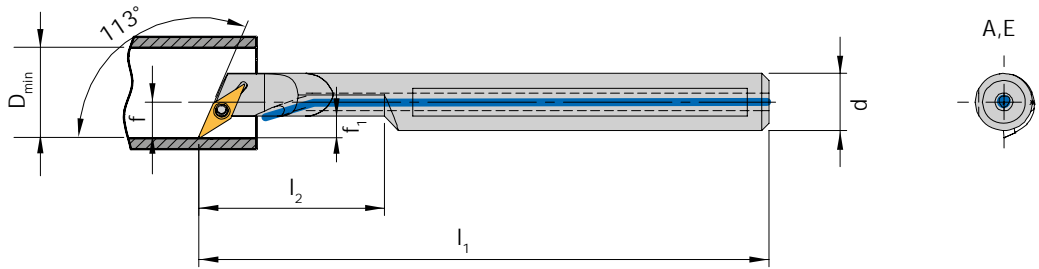

Rechte Ausführung abgebildet
Right-hand execution shown
Versione destra in figura

Bohrstangen – Stahlschaft mit innerer Kühlmittelzufuhr

Boring bar – Steel shank with through tool coolant

Bareno – Stelo in acciaio con foro refrigerante

Bezeichnung Designation Articolo	d	l ₁	l ₂	f	f ₁	D _{min}	Wendeschneidplatte Insert Inserto
A08F SVXCR 05	8	80	15	5	3	9,2	VC.. 0501...
A08F SVXCL 05	8	80	15	5	3	9,2	VC.. 0501...

Bohrstangen – Vollhartmetallschaft mit innerer Kühlmittelzufuhr

Boring bar – Carbide shank with through tool coolant

Bareno – Stelo in metallo duro integrale con foro refrigerante

Bezeichnung Designation Articolo	d	l ₁	l ₂	f	f ₁	D _{min}	Wendeschneidplatte Insert Inserto
E08F SVXCR 05	8	80	26	5	3	9,2	VC.. 0501...
E08F SVXCL 05	8	80	26	5	3	9,2	VC.. 0501...

Ersatzteile / Spare parts / Ricambi

Für Bohrstange For boring bar Per bareno	Schraube Screw Vite	Schlüssel Key Chiave
..08.. SVXC.. 05	VT1605	BT05

SV95C R/L Anstellwinkel / Approach angle / Angolo di attacco: 95°

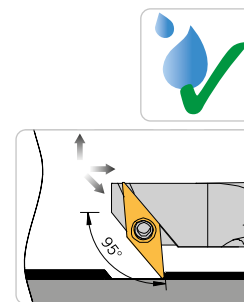
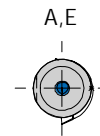
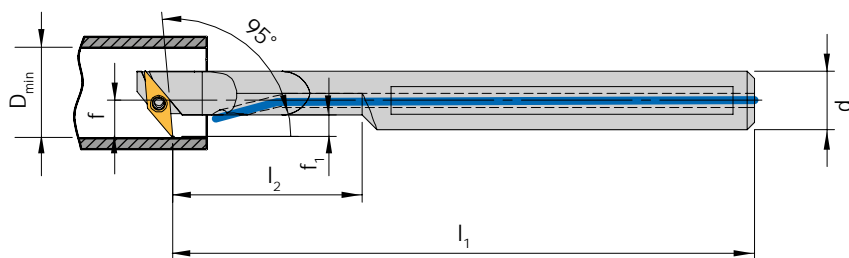

Rechte Ausführung abgebildet
Right-hand execution shown
Versione destra in figura

Bohrstangen – Stahlschaft mit innerer Kühlmittelzufuhr

Boring bar – Steel shank with through tool coolant

Bareno – Stelo in acciaio con foro refrigerante

Bezeichnung Designation Articolo	d	l ₁	l ₂	f	f ₁	D _{min}	Wendeschneidplatte Insert Inserto
A08F SV95CR 05	8	80	15	5	3	9,2	VC.. 0501...
A08F SV95CL 05	8	80	15	5	3	9,2	VC.. 0501...

Bohrstangen – Vollhartmetallschaft mit innerer Kühlmittelzufuhr

Boring bar – Carbide shank with through tool coolant

Bareno – Stelo in metallo duro integrale con foro refrigerante

Bezeichnung Designation Articolo	d	l ₁	l ₂	f	f ₁	D _{min}	Wendeschneidplatte Insert Inserto
E08F SV95CR 05	8	80	26	5	3	9,2	VC.. 0501...
E08F SV95CL 05	8	80	26	5	3	9,2	VC.. 0501...

Ersatzteile / Spare parts / Ricambi

Für Bohrstange For boring bar Per bareno	Schraube Screw Vite	Schlüssel Key Chiave
..08.. SV95C.. 05	VT1605	BT05

AM5115

- Für die Bearbeitung rostfreier und warmfester Stähle
- Für glatte bis leicht unterbrochene Schnitte geeignet
- Hohe Beständigkeit gegen Oxidation und Kerbverschleiß
- *For machining stainless and heat resistant steels*
- *For smooth to slightly interrupted cuts*
- *High resistance to oxidation and notch wear*
- Per la lavorazione di acciai inossidabili e resistenti alle alte temperature
- Adatto per tagli lisci o leggermente interrotti
- Elevata resistenza all'ossidazione e all'usura da intaglio

PVD



Verschleißfestigkeit
Wear resistance
Resistenza all'usura

Zähigkeit
Toughness
Tenacità



AM5125

- Für die Bearbeitung rostfreier und warmfester Stähle
- Für wechselnde Schnitttiefen und unterbrochene Schnitte geeignet
- Hohe Beständigkeit gegen Oxidation und Kerbverschleiß
- *For machining stainless and heat resistant steels*
- *For smooth to slightly interrupted cuts*
- *High resistance to oxidation and notch wear*
- Per la lavorazione di acciai inossidabili e resistenti alle alte temperature
- Adatto per tagli lisci o leggermente interrotti
- Elevata resistenza all'ossidazione e all'usura da intaglio

PVD



Verschleißfestigkeit
Wear resistance
Resistenza all'usura

Zähigkeit
Toughness
Tenacità



PSF

- Für die Schlicht- und mittlere Bearbeitung rostfreier und warmfester Stähle
- Sehr gute Spankontrolle bei geringen Schnitttiefen
- Für hohe Toleranzgenauigkeiten
- *For finish machining and semi-roughing stainless and heat resistant steels*
- *Excellent chip control at low cutting depths*
- *For high tolerance accuracy*
- Per la finitura e la lavorazione media di acciai inossidabili e resistenti alle alte temperature
- Ottimo controllo della truciolatura con profondità di taglio ridotte
- Per elevate precisioni di tolleranza



Schlichten <i>Finishing</i> Finitura		Mittlere Bearbeitung <i>Medium machining</i> Medie asportazioni		Schruppen <i>Roughing</i> Sgrossatura	
P	M	K	N	S	H
○	○	○	○	●	○

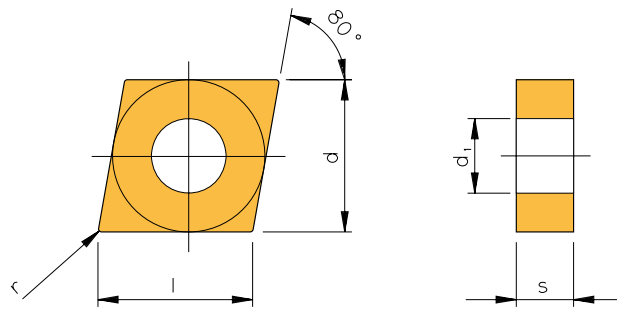

CC..



Bezeichnung Designation Articolo	l	d	s	d ₁	r	beschichtet coated / rivestito		
						AM5020	AM5115	AM5125
CCGT 0602005FN-PS	6,45	6,350	2,38	2,8	0,05	◆		
CCGT 09T3005FN-PS	9,67	9,525	3,97	4,4	0,05	◆		
CCMT 060202EN-PSF	6,45	6,350	2,38	2,8	0,2		◆	◆
CCMT 060204EN-PSF	6,45	6,350	2,38	2,8	0,4		◆	◆
CCMT 09T302EN-PSF	9,67	9,525	3,97	4,4	0,2		◆	◆
CCMT 09T304EN-PSF	9,67	9,525	3,97	4,4	0,4		◆	◆

- Hauptanwendung
Main application
Applicazione principale
- Nebenanwendung
Secondary application
Applicazione secondaria

P	○		
M	●	○	○
K			
N			
S		●	●
H			

CD..

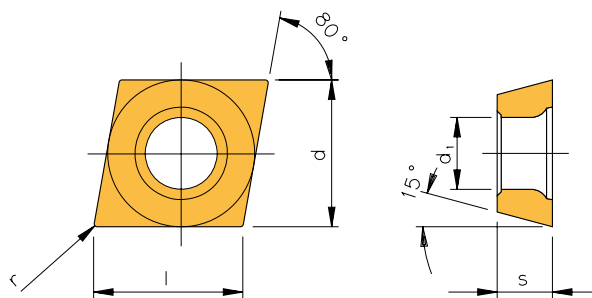
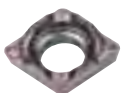

Bezeichnung Designation Articolo	l	d	s	d ₁	r	beschichtet coated / rivestito
						AM5130
CDMT 040102EN-PS2	4,03	3,97	1,0	2,1	0,2	◆
CDMT 040104EN-PS2	4,03	3,97	1,0	2,1	0,4	◆

Achtung: Bezeichnung entspricht nicht der ISO-Norm
Attention: Designation does not correspond to ISO-designation
Attenzione: Articolo non corrispondente alla classificazione ISO

- Hauptanwendung
Main application
Applicazione principale
- Nebenanwendung
Secondary application
Applicazione secondaria

P	
M	●
K	
N	
S	●
H	

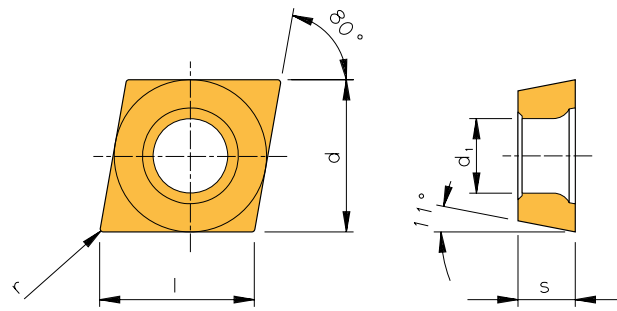

CP.



Bezeichnung Designation Articolo	l	d	s	d ₁	r	beschichtet coated / rivestito AM5130
CPMT 05T102EN-PS2	5,60	5,560	1,98	2,5	0,2	◆
CPMT 05T104EN-PS2	5,60	5,560	1,98	2,5	0,4	◆

- **Hauptanwendung**
Main application
Applicazione principale
- **Nebenanwendung**
Secondary application
Applicazione secondaria

P	
M	●
K	
N	
S	●
H	

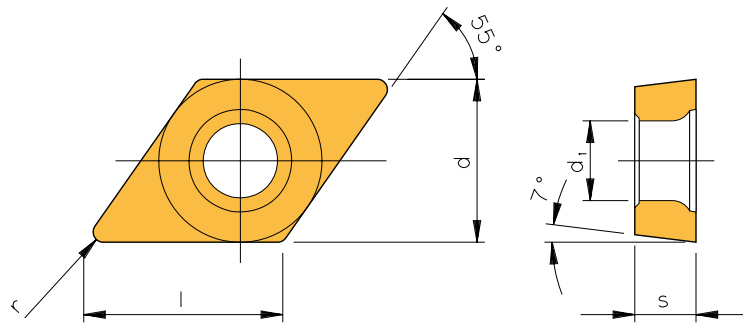

DC..



Bezeichnung Designation Articolo	l	d	s	d ₁	r	beschichtet coated / rivestito		
						AM5115	AM5125	AM5130
DCGT 04T002EN	3,78	3,1	1,2	1,7	0,2			◆
DCMT 070202EN-PSF	7,75	6,350	2,38	2,8	0,2	◆	◆	
DCMT 070204EN-PSF	7,75	6,350	2,38	2,8	0,4	◆	◆	
DCMT 11T302EN-PSF	11,6	9,525	3,97	4,4	0,2	◆	◆	
DCMT 11T304EN-PSF	11,6	9,525	3,97	4,4	0,4	◆	◆	
DCMT 11T308EN-PSF	11,6	9,525	3,97	4,4	0,8	◆	◆	

- Hauptanwendung
Main application
Applicazione principale
- Nebenanwendung
Secondary application
Applicazione secondaria

P	○		
M	●	○	○
K			
N			
S		●	●
H			

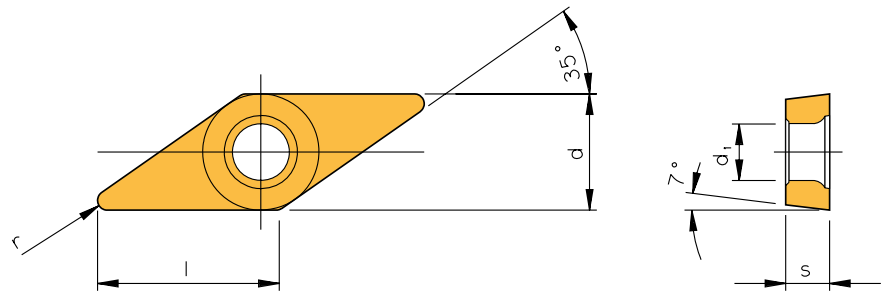

VC..



Bezeichnung Designation Articolo	l	d	s	d ₁	r	beschichtet coated / rivestito				
						AM5015	AM5115	AM5120	AM5125	AM5130
VCGT 1103003FL-PF2	11,1	6,35	3,18	2,8	0,03	◆				
VCGT 1103003FR-PF2	11,1	6,35	3,18	2,8	0,03	◆				
VCGT 050101EN-PS2	5,4	3,1	1,62	1,7	0,1			◆		
VCGT 050102EN-PS2	5,4	3,1	1,62	1,7	0,2			◆		
VCGT 050104EN-PS2	5,4	3,1	1,62	1,7	0,4			◆		
VCMT 070202EN-PS2	6,92	3,97	2,38	2,2	0,2					◆
VCMT 070204EN-PS2	6,92	3,97	2,38	2,2	0,4					◆
VCMT 110302EN-PSF	11,1	6,35	3,18	2,8	0,2		◆		◆	
VCMT 110304EN-PSF	11,1	6,35	3,18	2,8	0,4		◆		◆	

	P	M	K	N	S	H
● Hauptanwendung Main application Applicazione principale	●	●	○	○	●	○
○ Nebenanwendung Secondary application Applicazione secondaria	○	○	○	○	○	○

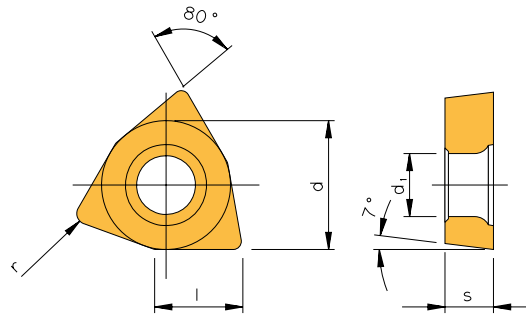

WC..



Bezeichnung Designation Articolo	l	d	s	d ₁	r	beschichtet coated / rivestito AM5130
WCMT 020102EN-PS2	2,70	3,97	1,59	2,20	0,2	◆
WCMT 020104EN-PS2	2,70	3,97	1,59	2,20	0,4	◆

- **Hauptanwendung**
Main application
Applicazione principale
- **Nebenanwendung**
Secondary application
Applicazione secondaria

P	
M	●
K	
N	
S	●
H	

Für höchste Ansprüche: Hochpositive Wendeschneidplatten

For the most demanding applications: High positive inserts

Per lavorazioni esigenti: Inserti Ultra Positivi



Neue Technologien und die steigende Vielfalt an zu bearbeitenden Werkstoffen führen zum Einsatz immer neuer Werkzeuge und Schneidstoffe. Mit diesen speziell entwickelten hochpositiven Spanformgeometrien und unter Verwendung von Hochleistungsschneidstoffen werden beste Zerspanungsergebnisse erzielt.

New technologies and the growing diversity of material grades create the need for new tools and cutting materials. With the ARNO® developed special high positive geometry and the use of different kinds of coatings we provide best cutting performance in a multitude of materials.

Le nuove tecnologie e la crescente varietà di materiali da lavorare portano all'utilizzo di nuovi prodotti e materiali da taglio. Con queste specifiche geometrie positive ARNO® appositamente studiate e realizzate utilizzando materiali da taglio ad alte prestazioni, sarà possibile ottenere le migliori prestazioni in termini di durata e finitura.

AM5020

- Für die Schlichtbearbeitung rostfreier und warmfester Stähle
- Hohe Zähigkeit und gute Verschleißfestigkeit
- Optimal beim Feindrehen von schwierigen Werkstoffen
- *For finish machining stainless and heat resistant steels*
- *High degree of toughness and good wear resistance*
- *Ideal for precision turning difficult materials*
- Per la finitura di acciai inossidabili e resistenti alle alte temperature
- Elevata durezza e buona resistenza all'usura
- Ottimale per la tornitura di finitura di materiali difficili da lavorare

PVD



Verschleißfestigkeit

Wear resistance

Resistenza all'usura



Zähigkeit

Toughness

Tenacità

Wendeschneidplatten

Inserts
Inserti

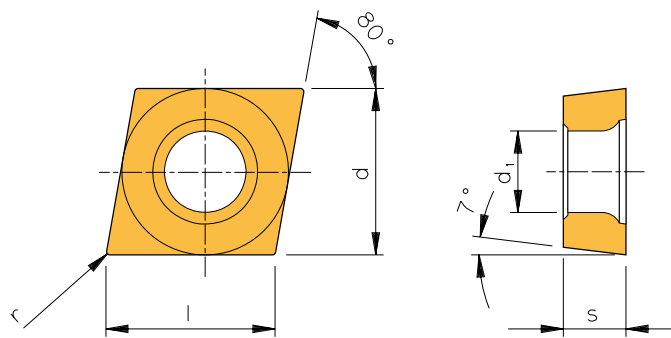

CC..



Bezeichnung Designation Articolo	l	d	s	d ₁	r
CCGT 09T3005FN-ALU	9,67	9,525	3,97	4,4	0,05
CCGT 060202EN-ASF	6,45	6,350	2,38	2,8	0,20
CCGT 060204EN-ASF	6,45	6,350	2,38	2,8	0,40
CCGT 09T3005FN-ASF	9,67	9,525	3,97	4,4	0,05
CCGT 09T302EN-ASF	9,67	9,525	3,97	4,4	0,20
CCGT 09T304EN-ASF	9,67	9,525	3,97	4,4	0,40

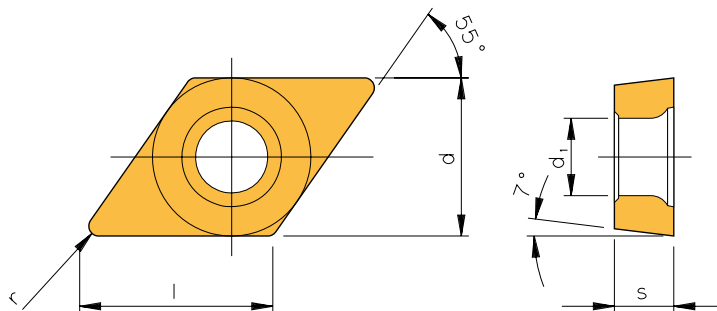

DC..



Bezeichnung Designation Articolo	l	d	s	d ₁	r	unbeschichtet uncoated non rivestito
DCFT 070202FN-ASF	9,67	9,525	3,97	4,4	0,05	AK10

P	
M	
K	○
N	●
S	
H	

- Hauptanwendung
Main application
Applicazione principale
- Nebenanwendung
Secondary application
Applicazione secondaria

	AM5020	AL10	AL20	AT10	AT20	PVD1	unbeschichtet uncoated / non rivestito			Bezeichnung Designation Articolo
							AK10	AK20	AK1020	
							◆			CCGT 09T3005FN-ALU
	◆								◆	CCGT 060202EN-ASF
	◆								◆	CCGT 060204EN-ASF
		◆	◆	◆	◆	◆	◆	◆		CCGT 09T3005FN-ASF
	◆								◆	CCGT 09T302EN-ASF
	◆								◆	CCGT 09T304EN-ASF
P	○	●	●	○	○	○				
M	●	●	●	○	○	○				
K		○	○	○	○		○	○	○	
N				●	●	●	●	●	●	
S		○	○							
H		○	○							

- Hauptanwendung
Main application
Applicazione principale
- Nebenanwendung
Secondary application
Applicazione secondaria

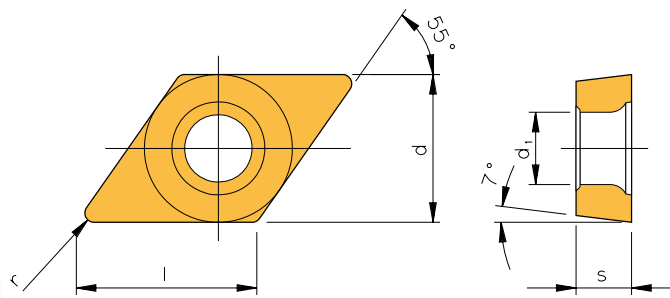

DC..



Bezeichnung Designation Articolo	l	d	s	d ₁	r	beschichtet coated / rivestito		unbeschichtet uncoated / non rivestito		
						AM5020		AK10	AK20	AK1020
DCGT 04T001FN-ALU	3,78	3,100	1,20	1,7	0,1	◆		◆	◆	◆
DCGT 04T002FN-ALU	3,78	3,100	1,20	1,7	0,2	◆		◆	◆	◆
DCGT 04T004FN-ALU	3,78	3,100	1,20	1,7	0,4	◆			◆	◆
DCGT 04T002EN-ASF N	3,78	3,1	1,2	1,7	0,2	◆				◆
DCGT 04T002FN-ASF N	3,78	3,1	1,2	1,7	0,2				◆	
DCGT 0702008FN-ASF	7,75	6,350	2,38	2,8	0,08	◆		◆		◆
DCGT 0702015FN-ASF	7,75	6,350	2,38	2,8	0,15	◆		◆		◆
DCGT 070202EN-ASF	7,75	6,350	2,38	2,8	0,20	◆				◆
DCGT 070204EN-ASF	7,75	6,350	2,38	2,8	0,40	◆				◆
DCGT 11T3008FN-ASF	11,6	9,525	3,97	4,4	0,08	◆		◆		◆
DCGT 11T3015FN-ASF	11,6	9,525	3,97	4,4	0,15	◆		◆		◆
DCGT 11T302EN-ASF	11,6	9,525	3,97	4,4	0,20	◆				◆
DCGT 11T304EN-ASF	11,6	9,525	3,97	4,4	0,40	◆				◆

- Hauptanwendung
Main application
Applicazione principale
- Nebenanwendung
Secondary application
Applicazione secondaria

	P	M	K	N	S	H
●	○	●				
○			○	○	○	
			●	●	●	

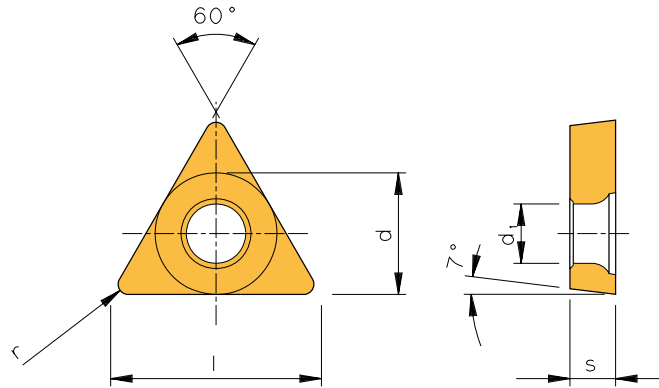

TC..



Bezeichnung Designation Articolo	l	d	s	d ₁	r	beschichtet coated rivestito				unbeschichtet uncoated non rivestito	
						AM5015	AM5025	AL10	AL20	AK10	AK20
TCGT 090208FN-ALU	9,6	5,56	2,38	2,5	0,8					◆	◆
TCGT 090202EN-ASF	9,6	5,56	2,38	2,5	0,2	◆	◆				◆
TCGT 090202FN-ASF	9,6	5,56	2,38	2,5	0,2			◆	◆	◆	◆

- Hauptanwendung
Main application
Applicazione principale
- Nebenanwendung
Secondary application
Applicazione secondaria

P	●		●	●		
M	●	●	●	●		
K	○		○	○	○	○
N					●	●
S	●	●	○	○		
H	○		○	○		

VC..

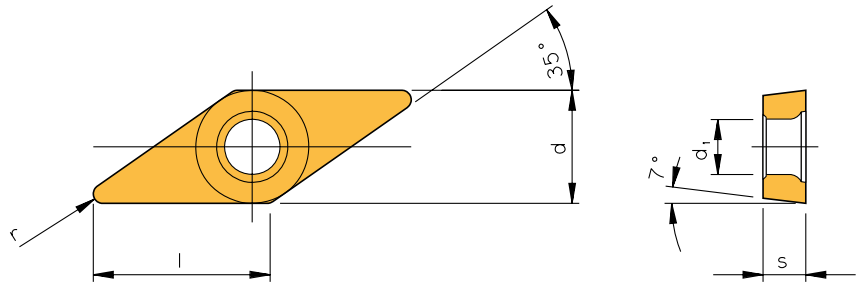

Bezeichnung Designation Articolo	l	d	s	d ₁	r	beschichtet coated / rivestito		unbeschichtet uncoated / non rivestito		
						AM5020	AP5210	AK10	AK20	AK1020
VCGT 050101FN-ALU	5,4	3,100	1,62	1,7	0,10			◆		
VCGT 050102FN-ALU	5,4	3,100	1,62	1,7	0,20			◆		
VCGT 050104FN-ALU	5,4	3,100	1,62	1,7	0,40			◆		
VCGT 110301FN-ALU	11,1	6,350	3,18	2,9	0,10		◆			
VCGT 110302FN-ALU	11,1	6,350	3,18	2,9	0,20		◆			
VCGT 110304FN-ALU	11,1	6,350	3,18	2,9	0,40		◆			
VCGT 130304FN-ALU	13,1	7,940	3,18	3,2	0,40		◆			
VCGT 160402FN-ALU	16,6	9,525	4,76	4,4	0,20		◆			
VCGT 050102EN-ASF N	5,4	3,1	1,62	1,7	0,2					◆
VCGT 050102FN-ASF N	5,4	3,1	1,62	1,7	0,2				◆	◆
VCGT 1103008FN-ASF	11,1	6,3500	3,18	2,9	0,08	◆		◆		◆
VCGT 1103015FN-ASF	11,1	6,3500	3,18	2,9	0,15	◆		◆		◆
VCGT 110302EN-ASF	11,1	6,3500	3,18	2,9	0,20	◆				◆
VCGT 110302FN-ASF N	11,1	6,35	3,18	2,9	0,2					◆
VCGT 110304EN-ASF	11,1	6,3500	3,18	2,9	0,40	◆				◆

- Hauptanwendung
Main application
Applicazione principale
- Nebenanwendung
Secondary application
Applicazione secondaria

	P	M	K	N	S	H
AM5020	●					
AP5210	○	○				
AK10			○	○	○	
AK20			●	●	●	
AK1020						●

ARNO® WERKZEUGE

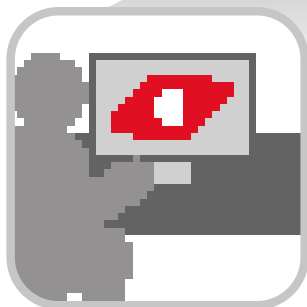

KONSTRUKTION
CONSTRUCTION
COSTRUZIONE

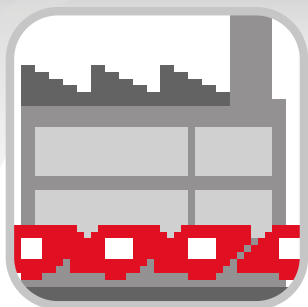

PRODUKTION
PRODUCTION
PRODUZIONE



VERTRIEB
DISTRIBUTION
DISTRIBUZIONE



ANWENDUNGSTECHNIK
TECHNICAL ADVISE
SERVIZIO TECNICO

Schnell, flexibel und individuell.

Quick, flexible and individual.

Veloce, flessibile e individuale.

Konstruktion, Produktion und Vertrieb unter einem Dach.

Das ist die perfekte Verbindung, um Ihnen Standard- und Sonderprodukte schnell und hochwertig anbieten zu können.

95% der Standardprodukte sind sofort verfügbar: Bei Bestellung bis 18 Uhr erhalten Sie Ihre Produkte bereits am nächsten Tag.

Mit großer fachlicher Kompetenz betreut Sie unser Außendienst-Team, unsere Anwendungstechniker helfen Ihnen mit Spezialwissen gerne auch vor Ort.

To have design, production and service all under one roof

is the perfect way of providing standard and special products.

95% of the standard programme is available from stock. Order received before 18.00 CET are dispatched the very same day and in most cases supplied next day.

Our competent team of technical sales engineers will be available to support you on site.

Costruzione, Produzione e Distribuzione sotto un unico tetto.

La sequenza perfetta per garantire un servizio di supporto cliente su prodotti Standard e Speciali di alta qualità.

Il 95% dei prodotti Standard sono disponibili a stock; con ordini entro le 18:00 garantiamo la consegna il giorno successivo.

Il nostro team di vendita altamente qualificato si offre come supporto alla produzione presso i nostri clienti direttamente sul territorio.

Weitere Informationen finden Sie unter:

For more information see:

Altre informazioni su:

www.arno.de

Sortiment erweitert *Portfolio expanded* Ampliamento gamma



Neue CERMET-Sorte zum Schlichten- bis mittlere Zerspanung von Stahl und rostfreiem Stahl. Die geschliffenen oder gesinterten Wendeschneidplatten werden bei klebenden Anwendungen, bei denen Aufbauschneidenbildung ein Problem darstellt, eingesetzt. Selbst nach langen Schnittzeiten hält die Sorte AP6010 die Schnittkräfte niedrig. Bei Schlichtvorgängen verlängert sich die Standzeit und ermöglicht enge Toleranzen sowie gute Oberflächenqualitäten.

New cermet grade for finishing to medium machining of steel and stainless steel. Both the ground and the sintered inserts are applied where build up edge is a problem. Even after prolonged effective cutting time the AP6010 maintains its low cutting forces. While finishing the insert tool life is extended, part tolerances kept tight and surface finish remains excellent.

Nuova qualità Cermet per la finitura e semifinitura di acciaio e acciaio inox. Sia gli inserti rettificati che quelli sinterizzati sono idonei per limitare il tagliante di riporto, l'usura alle elevate velocità di taglio ed una migliore finitura. La qualità garantisce quindi basse forze di taglio per tempi di lavoro prolungati.

Fakten / Features / Caratteristiche

- Oberflächen bekommen einen besonderen Glanz
- Enge Toleranzen können eingehalten werden
- Hohe Schnittgeschwindigkeit ermöglichen kürzere Bearbeitungszeiten
- Trockenbearbeitung möglich
- *Especially good surface finish*
- *Holds tight tolerances*
- *Higher cutting speeds improves productivity*
- *Dry machining possible*
- Sviluppata per finiture superficiali
- Mantiene strette tolleranze
- Maggiore velocità di taglio migliora la produttività
- Lavorazione a secco ove possibile

Grade discription
Descrizione della Qualità

AP6010

- Hohe Schnittgeschwindigkeiten
- Hohe Standzeiten
- Gute Verschleißfestigkeit
- High cutting speeds
- Long tool life
- Good wear resistance
- Elevate velocità di taglio
- Elevata durata
- Buona resistenza all'usura



Verschleißfestigkeit
Wear resistance
Resistenza all'usura

Zähigkeit
Toughness
Tenacità



Weitere Sorten und Geometrien finden Sie im ARNO® Katalog „Drehen und Gewindedrehen“ Kapitel 3.

For more grades and geometries please see our ARNO® catalogue "Turning and Threading" chapter 3.

Per ulteriori qualità e gradi disponibili vedere il nostro catalogo ARNO® "Tornitura e Filettatura", Capitolo 3

PM1

- Hohe Prozesssicherheit
- Exzellente Spankontrolle
- Besonders geeignet zur Bearbeitung von Stahl und rostfreien Stählen
- *High process reliability*
- *Excellent chip control*
- *Specially for machining steel and stainless steels*
- Elevata sicurezza di processo
- Eccellente controllo della truciolatura
- Particolarmente adatto per la lavorazione di acciaio e di acciai inossidabili



Schlichten <i>Finishing</i> Finitura		Mittlere Bearbeitung <i>Medium machining</i> Medie asportazioni			Schruppen <i>Roughing</i> Sgrossatura	
P	M	K	N	S	H	
●	●	●	○	●	○	

PS2

- Hohe Oberflächengüten und Toleranzgenauigkeit
- Spanbrecher für kontrollierten Spanbruch
- Scharfe Schneidkante
- *High surface quality and tolerance accuracy*
- *Chip breaker for controlled chip breakage*
- *Sharp cutting edge*
- Elevate finiture superficiali e precisione di tolleranza
- Rompitruciolo per la rottura controllata dei trucioli
- Tagliente affilato



Schlichten <i>Finishing</i> Finitura		Mittlere Bearbeitung <i>Medium machining</i> Medie asportazioni			Schruppen <i>Roughing</i> Sgrossatura	
P	M	K	N	S	H	
●	●	○	○	●	○	

AY

- Scharfe Schneidkante
- Hohe Oberflächengüten
- Geeignet für Stahl und rostfreie Stähle
- *Sharp cutting edge*
- *High surface quality*
- *For steel and stainless steels*
- Tagliente affilato
- Elevate finiture superficiali
- Adatto per acciaio e acciai inossidabili



Schlichten <i>Finishing</i> Finitura		Mittlere Bearbeitung <i>Medium machining</i> Medie asportazioni			Schruppen <i>Roughing</i> Sgrossatura	
P	M	K	N	S	H	
●	●	○	○	○	○	

AZ

- Zur Bearbeitung von Stahl, Stahlguss und nichtrostenden Stählen
- Geschliffene Geometrie
- Umlaufende Spanleitstufe
- *For machining steel, cast steel and stainless steels*
- *Ground geometry*
- *Peripheral chip breaker*
- Per la lavorazione dell'acciaio, dell'acciaio fuso e degli acciai inossidabili
- Geometria rettificata
- Canale rompitruciolo sulla circonferenza



Schlichten <i>Finishing</i> Finitura		Mittlere Bearbeitung <i>Medium machining</i> Medie asportazioni			Schruppen <i>Roughing</i> Sgrossatura	
P	M	K	N	S	H	
●	●	○				

PS

- Sehr gut geeignet für Langdrehanwendungen
- Scharfe Schneidkante
- Gerade Schneidkante
- *Excellent for Swiss type machining applications*
- *Sharp cutting edge*
- *Straight cutting edge*
- Particolarmente adatto per le applicazioni di tornitura a fantina mobile
- Tagliente affilato
- Tagliente diritto



Schlichten <i>Finishing</i> Finitura		Mittlere Bearbeitung <i>Medium machining</i> Medie asportazioni			Schruppen <i>Roughing</i> Sgrossatura	
P	M	K	N	S	H	
○	●	○	●	●		

U

- Gute Spanlenkung bei geringem Vorschub
- Geringe Schnittkraft
- Bestens geeignet für die Stahlzerspanung
- *Good chip control at low feed rate*
- *Low cutting force*
- *Excellent for cutting steel*
- Buon controllo del truciolo con avanzamento ridotto
- Ridotta forza di taglio
- Particolarmente adatto per la lavorazione ad asportazione di truciolo dell'acciaio



Schlichten <i>Finishing</i> Finitura		Mittlere Bearbeitung <i>Medium machining</i> Medie asportazioni			Schruppen <i>Roughing</i> Sgrossatura	
P	M	K	N	S	H	
●	●	○				

Inserts
Inserti

CC..

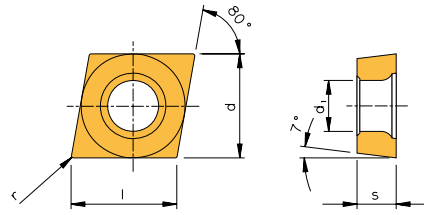

Bezeichnung Designation Articolo	l	d	s	d ₁	r	Sorten / Grades / Qualità
						unbeschichtet / uncoated / non rivestito
CCGT 060201FN-AZ	6,40	6,350	2,38	2,8	0,10	AP6010 ◆
CCGT 060202FN-AZ	6,40	6,350	2,38	2,8	0,20	◆
CCGT 060204FN-AZ	6,40	6,350	2,38	2,8	0,40	◆
CCGT 09T302FN-AZ	9,70	9,525	3,97	4,4	0,20	◆
VCGT 110301FN-AZ	11,10	6,350	3,18	2,8	0,10	◆
CCGT 060201FR-U	6,45	6,350	2,38	2,8	0,10	◆
CCGT 060201FL-U	6,45	6,350	2,38	2,8	0,10	◆
CCGT 060202FR-U	6,45	6,350	2,38	2,8	0,20	◆
CCGT 09T302FR-U	9,67	9,525	3,97	4,4	0,20	◆
CCGT 09T302FL-U	9,67	9,525	3,97	4,4	0,20	◆
CCGT 0602005FN-PS	6,45	6,350	2,38	2,8	0,05	◆
CCGT 060201FN-PS	6,45	6,350	2,38	2,8	0,10	◆
CCGT 060202FN-PS	6,45	6,350	2,38	2,8	0,20	◆
CCGT 09T3005FN-PS	9,67	9,525	3,97	4,4	0,05	◆
CCGT 09T301FN-PS	9,67	9,525	3,97	4,4	0,10	◆
CCGT 09T302FN-PS	9,67	9,525	3,97	4,4	0,20	◆
CCGT 09T304FN-PS	9,67	9,525	3,97	4,4	0,40	◆
CCMT 060202EN-PM1	6,45	6,350	2,38	2,8	0,20	◆
CCMT 060204EN-PM1	6,45	6,350	2,38	2,8	0,40	◆
CCMT 09T302EN-PM1	9,67	9,525	3,97	4,4	0,20	◆
CCMT 09T304EN-PM1	9,67	9,525	3,97	4,4	0,40	◆

● Hauptanwendung
Main application
Applicazione principale

○ Nebenanwendung
Secondary application
Applicazione secondaria

P	●
M	○
K	
N	
S	
H	

Inserts
Inserti

CD..

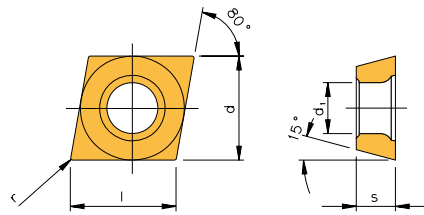

Bezeichnung	l	d	s	d ₁	r	Sorten Grades / Qualità
						unbeschichtet uncoated non rivestito
CDMT 040102EN-PM1	4,03	3,970	1,0	2,1	0,2	AP6010
CDMT 040104EN-PM1	4,03	3,970	1,0	2,1	0,4	◆
CDMT 040102EN-PS2	4,03	3,970	1,0	2,1	0,2	◆
CDMT 040104EN-PS2	4,03	3,970	1,0	2,1	0,4	◆

Achtung: Bezeichnung entspricht nicht der ISO-Norm
Attention: Designation does not correspond to ISO-designation
Attenzione: Articolo non corrispondente alla classificazione ISO

● Hauptanwendung Main application Applicazione principale	P	●
	M	○
○ Nebenanwendung Secondary application Applicazione secondaria	K	
	N	
	S	
	H	

CP..

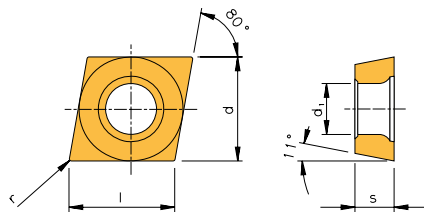



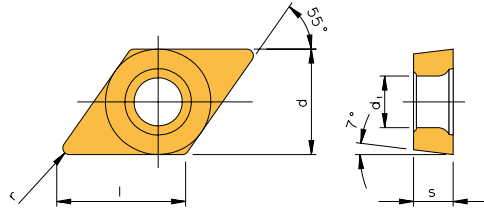

Bezeichnung Designation Articolo	l	d	s	d ₁	r	Sorten Grades / Qualità
						unbeschichtet uncoated non rivestito
CPMT 05T102EN-PM1	5,60	5,56	1,98	2,5	0,2	AP6010
CPMT 05T104EN-PM1	5,60	5,56	1,98	2,5	0,4	◆
CPMT 05T102EN-PS2	5,60	5,56	1,98	2,5	0,2	◆
CPMT 05T104EN-PS2	5,60	5,56	1,98	2,5	0,4	◆

● Hauptanwendung Main application Applicazione principale	P	●
	M	○
○ Nebenanwendung Secondary application Applicazione secondaria	K	
	N	
	S	
	H	



DC..

Bezeichnung Designation Articolo	l	d	s	d ₁	r	Sorten Grades / Qualità
						unbeschichtet uncoated non rivestito
 DCGT 070201FN-AZ	7,70	6,350	2,38	2,8	0,10	AP6010 ◆
DCGT 070202FN-AZ	7,70	6,350	2,38	2,8	0,20	◆
DCGT 070204FN-AZ	7,70	6,350	2,38	2,8	0,40	◆
DCGT 11T302FN-AZ	11,60	9,525	3,97	4,4	0,20	◆
DCGT 11T304FN-AZ	11,60	9,525	3,97	4,4	0,40	◆
 DCGT 070201FR-U	7,70	6,350	2,38	2,8	0,10	◆
DCGT 070202FR-U	7,70	6,350	2,38	2,8	0,20	◆
DCGT 070202FL-U	7,70	6,350	2,38	2,8	0,20	◆
 DCGT 0702005FN-PS	7,75	6,350	2,38	2,8	0,05	◆
DCGT 070201FN-PS	7,75	6,350	2,38	2,8	0,10	◆
DCGT 070202FN-PS	7,75	6,350	2,38	2,8	0,20	◆
DCGT 11T3005FN-PS	11,60	9,525	3,97	4,4	0,05	◆
DCGT 11T301FN-PS	11,60	9,525	3,97	4,4	0,10	◆
DCGT 11T302FN-PS	11,60	9,525	3,97	4,4	0,20	◆
DCGT 11T304FN-PS	11,60	9,525	3,97	4,4	0,40	◆
 DCMT 070202EN-PM1	7,75	6,350	2,38	2,8	0,20	◆
DCMT 070204EN-PM1	7,75	6,350	2,38	2,8	0,40	◆
DCMT 11T302EN-PM1	11,60	9,525	3,97	4,4	0,20	◆
DCMT 11T304EN-PM1	11,60	9,525	3,97	4,4	0,40	◆
DCMT 11T308EN-PM1	11,60	9,525	3,97	4,4	0,80	◆

● Hauptanwendung
Main application
Applicazione principale

○ Nebenanwendung
Secondary application
Applicazione secondaria

P	●
M	○
K	
N	
S	
H	

Inserts
Inserti

TC..

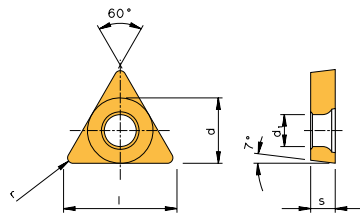

Bezeichnung Designation Articolo	l	d	s	d ₁	r	Sorten Grades / Qualità
						unbeschichtet uncoated non rivestito
TCMT 110204EN-PM1	11,00	6,35	2,38	2,8	0,4	AP6010 ◆
TCMT 110208EN-PM1	11,00	6,35	2,38	2,8	0,8	AP6010 ◆

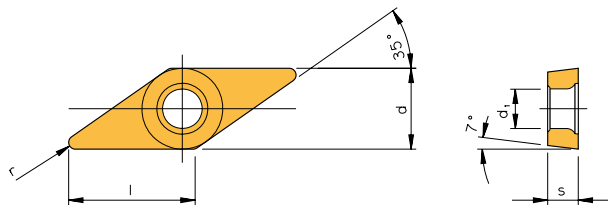

VC..



Bezeichnung Designation Articolo	l	d	s	d ₁	r	Sorten Grades / Qualità
						unbeschichtet uncoated non rivestito
VCGT 110302FL-AY	11,1	6,35	3,18	2,8	0,20	AP6010 ◆
VCGT 110302FR-AY	11,1	6,35	3,18	2,8	0,20	AP6010 ◆
VCGT 110302FN-AZ	11,1	6,35	3,18	2,8	0,20	AP6010 ◆
VCGT 110304FN-AZ	11,1	6,35	3,18	2,8	0,40	AP6010 ◆
VCGT 110301FR-U	11,1	6,35	3,18	2,8	0,10	AP6010 ◆
VCGT 110301FL-U	11,1	6,35	3,18	2,8	0,10	AP6010 ◆
VCGT 110302FR-U	11,1	6,35	3,18	2,8	0,20	AP6010 ◆
VCGT 110302FL-U	11,1	6,35	3,18	2,8	0,20	AP6010 ◆
VCGT 1103005FN-PS	11,1	6,35	3,18	2,8	0,05	AP6010 ◆
VCGT 110301FN-PS	11,1	6,35	3,18	2,8	0,10	AP6010 ◆
VCGT 110302FN-PS	11,1	6,35	3,18	2,8	0,20	AP6010 ◆
VCGT 110304FN-PS	11,1	6,35	3,18	2,8	0,40	AP6010 ◆
VCGT 050101EN-PS2	5,4	3,10	1,62	1,7	0,10	AP6010 ◆
VCGT 050102EN-PS2	5,4	3,10	1,62	1,7	0,20	AP6010 ◆
VCGT 050104EN-PS2	5,4	3,10	1,62	1,7	0,40	AP6010 ◆

● Hauptanwendung Main application Applicazione principale	P	●
	M	○
○ Nebenanwendung Secondary application Applicazione secondaria	K	
	N	
	S	
	H	

● Hauptanwendung Main application Applicazione principale	P	●
	M	○
○ Nebenanwendung Secondary application Applicazione secondaria	K	
	N	
	S	
	H	

Inserts
Inserti

VC..

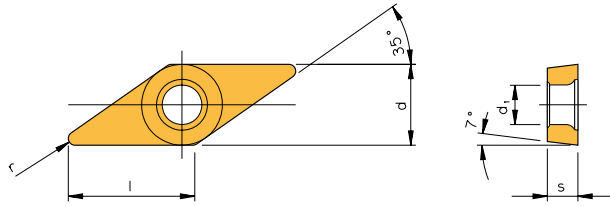

Bezeichnung Designation Articolo	l	d	s	d ₁	r	Sorten Grades / Qualità
						unbeschichtet uncoated non rivestito
VCMT 070202EN-PM1	6,92	3,970	2,38	2,2	0,2	AP6010
VCMT 070204EN-PM1	6,92	3,970	2,38	2,2	0,4	◆
VCMT 110302EN-PM1	11,10	6,350	3,18	2,8	0,2	◆
VCMT 110304EN-PM1	11,10	6,350	3,18	2,8	0,4	◆
VCMT 160404EN-PM1	16,50	9,525	4,76	4,4	0,4	◆
VCMT 160408EN-PM1	16,50	9,525	4,76	4,4	0,8	◆
VCMT 070202EN-PS2	6,92	3,970	2,38	2,2	0,2	◆
VCMT 070204EN-PS2	6,92	3,970	2,38	2,2	0,4	◆

- Hauptanwendung
Main application
Applicazione principale
- Nebenanwendung
Secondary application
Applicazione secondaria

P	●
M	○
K	
N	
S	
H	

WC..

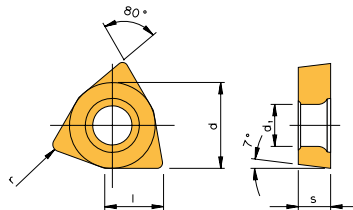

Bezeichnung Designation Articolo	l	d	s	d ₁	r	Sorten Grades / Qualità
						unbeschichtet uncoated non rivestito
WCMT 020102EN-PM1	2,70	3,97	1,59	2,2	0,2	AP6010
WCMT 020104EN-PM1	2,70	3,97	1,59	2,2	0,4	◆
WCMT 020102EN-PS2	2,70	3,97	1,59	2,2	0,2	◆
WCMT 020104EN-PS2	2,70	3,97	1,59	2,2	0,4	◆

- Hauptanwendung
Main application
Applicazione principale
- Nebenanwendung
Secondary application
Applicazione secondaria

P	●
M	○
K	
N	
S	
H	

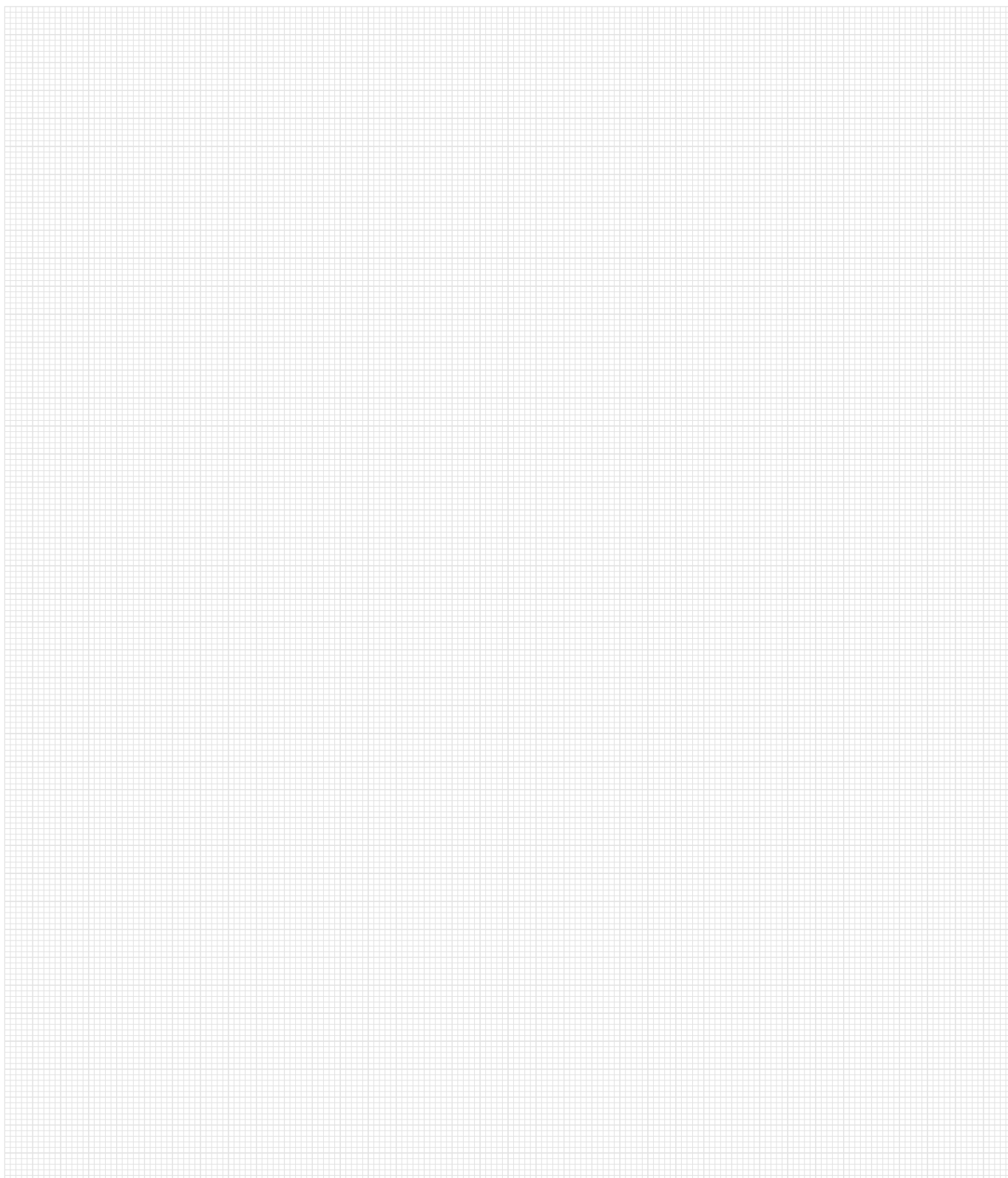

Weitere Informationen finden Sie unter
For more information see
Per maggiori informazioni visita il sito

www.arno.de

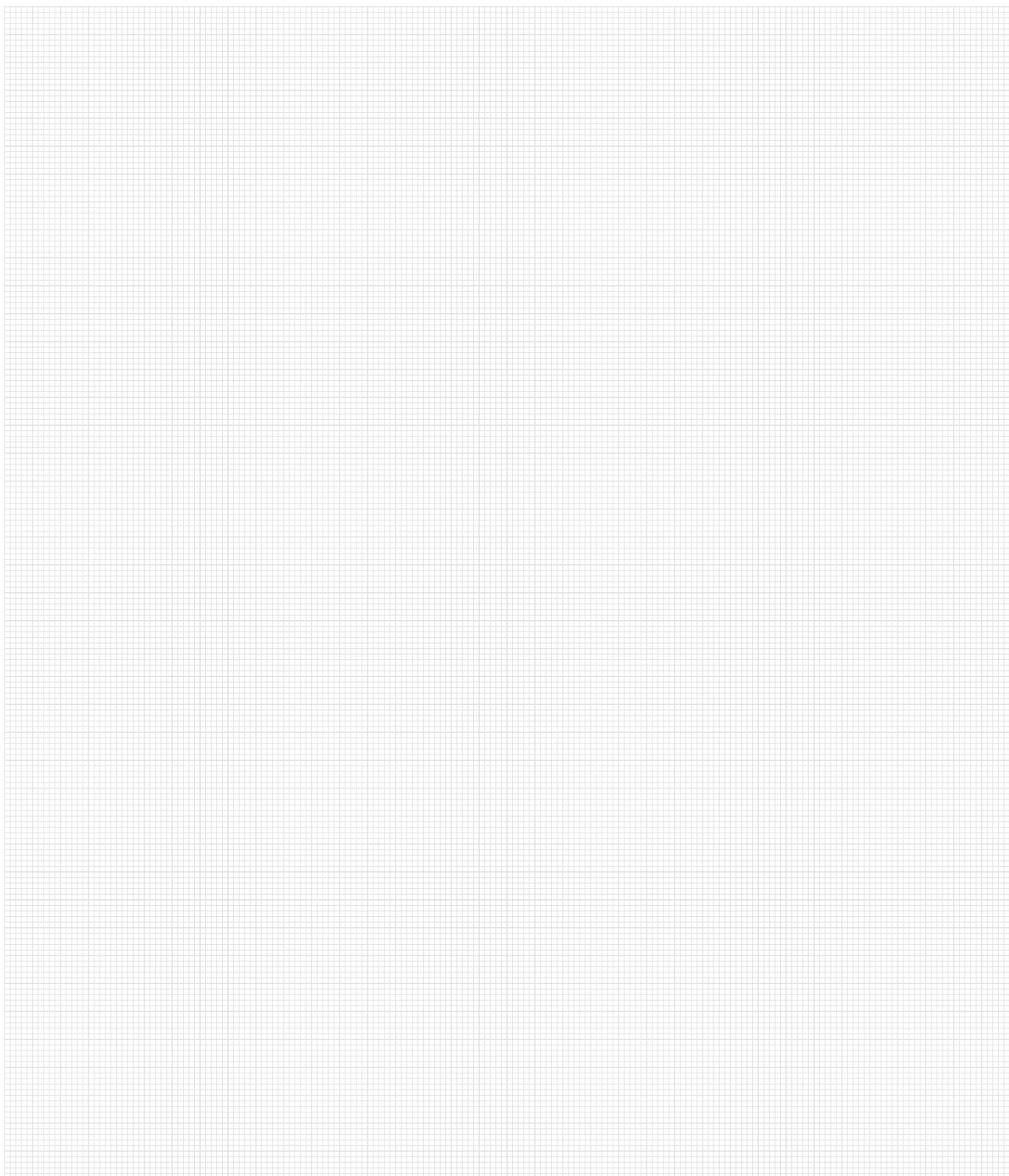

Weitere Informationen finden Sie unter
For more information see
Per maggiori informazioni visita il sito

www.arno.de

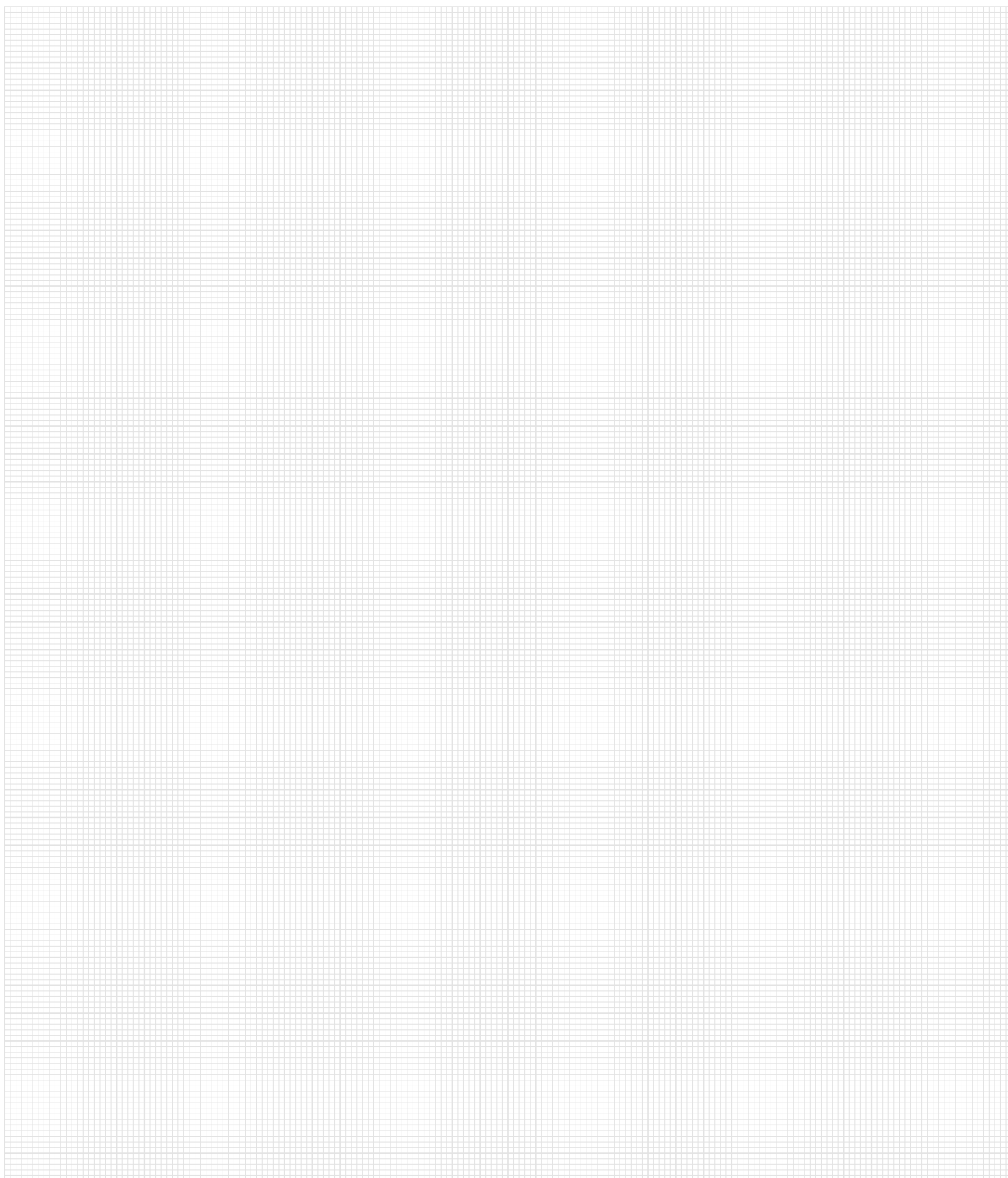

Weitere Informationen finden Sie unter
For more information see
Per maggiori informazioni visita il sito

www.arno.de



Werkzeuge und Schneideinsätze zum Ein- und Abstechen

Tools and inserts for parting and grooving

Utensili ed inserti di troncatura e scanalatura



Werkzeuge und Wendeschneidplatten zum Drehen und Gewindedrehen

Tooling and indexable inserts for turning and threading

Utensili ed inserti di tornitura e filettatura



Werkzeuge und Wendeschneidplatten zum Fräsen und Gewindefräsen

Milling cutters and indexable inserts for milling and thread milling

Utensili ed inserti di fresatura e filettatura di fresatura



Werkzeuge und Wendeschneidplatten zum Bohren

Drilling tools and indexable inserts for drilling

Utensili ed inserti di foratura

Fordern Sie unsere weiteren Broschüren oder den Gesamtkatalog an.

For further information please ask for our complete catalogue.

Per ulteriori informazioni richiedete la raccolta cataloghi completa.

Siamo sempre al vostro servizio.



Karl-Heinz Arnold GmbH
Karlsbader Str. 4 | D-73760 Ostfildern
Tel +49 (0)711 34 802 0
Fax +49 (0)711 34 802 130

bestellung@arno.de
anfrage@arno.de
www.arno.de

ARNO (UK) Limited | Unit 9, 10 & 11, Sugnall Business Centre
Sugnall, Eccleshall | Staffordshire | ST21 6NF
Tel +44 01785 850 072 | Fax +44 01785 850 076
sales@arno.de | www.arno-tools.co.uk

ARNO Italia S.r.l. | Via J. F. Kennedy 19 | 20871 Vimercate (MB)
Tel +39 039 68 52 101 | Fax +39 039 60 83 724
info@arno-italia.it | www.arno-italia.it

ARNO-Werkzeuge USA LLC | 1101 W. Diggins St.
US-60033 Harvard, Illinois
Tel +1 815 943 4426 | Fax +1 815 943 7156
info@arnousa.com | www.arnousa.com

ARNO RU Ltd. | Krassnaja Ul. 38 | RU-600015 Vladimir
Tel / Fax +7 4922 541125 | COT +7 4922 541135
info@arnoru.ru | www.arnoru.ru

ARNO Werkzeuge S.E.A. PTE. LTD. | 25 International Business Park
#04 - 70A German Center | SG-609916 Singapore
Tel +65 65130779 | Fax +65 68970042
info@arno.com.sg | www.arno.com.sg

AIF Cluses | 310 Rue des Îles | 74300 Cluses
Tél +33 (0)4 50 18 24 07 | Fax +33 (0)4 50 89 04 81
cluses@aif.fr

AIF - Ateliers de l'Île de France | 6 Rue des Entrepreneurs
CS30572 | 77272 Villeparisis Cedex
Tél +33 (0)1 64 27 03 30 | Fax +33 (0)1 64 27 03 49
info@aif.fr | www.aif.fr

AIF Sud | ZA des Massies | 2 Impasse du Bosquet
81800 Couffoueux
Tél +33 (0)5 63 33 60 42 | sud@aif.fr